

# Industrial Brakes

Brake Calipers • Clamping Units

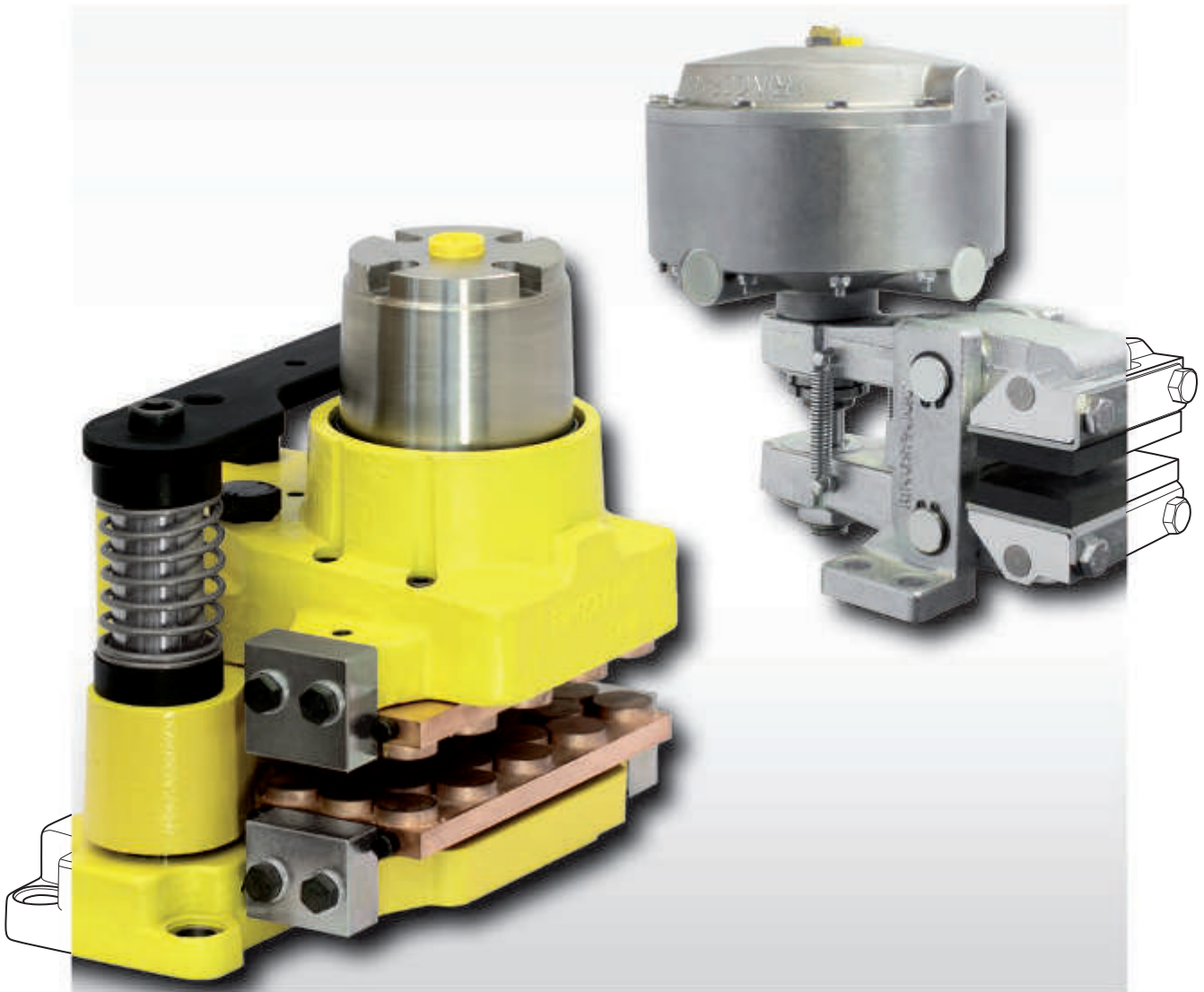

Edition 2016/2017



# Table of Contents

Brake Technology Introduction								Page		
Design and Function of Brakes								4		
Areas of Application for Brakes								6		
Type	Braking torque* [Nm]					Type of mounting brake at machine		Adjustment in case of friction block wear		Page
	10 <sup>2</sup>	10 <sup>3</sup>	10 <sup>4</sup>	10 <sup>5</sup>	10 <sup>6</sup>	Parallel to brake disc	At right angles to brake disc	Manual	Auto- matic	
<b>Brake Calipers spring activated – pneumatically released</b>										
DH 010 FPM	10 - 50						●	●		9
DV 020 FPM / DH 020 FPM	97 - 650					●	●	●		10
DH 025 FPM	250 - 1 900						●	●		12
DH 025 FPA	150 - 1 700						●		●	14
DV 030 FPM / DH 030 FPM	270 - 2 500					●	●	●		16
DV 030 FPA / DH 030 FPA	150 - 2 500					●	●		●	20
DV 035 FPM / DH 035 FPM	430 - 5 700					●	●	●		24
DV 035 FPA / DH 035 FPA	230 - 5 400					●	●		●	28
DU 060 FPM	2 700 - 38 500					●	●	●		32
<b>Brake Calipers spring activated – hydraulically released</b>										
DV 020 FHM / DH 020 FHM	200 - 650					●	●	●		34
DV 030 FHM / DH 030 FHM	620 - 2 000					●	●	●		36
DV 030 FHA / DH 030 FHA	620 - 2 000					●	●		●	38
DV 035 FHM / DH 035 FHM	1 500 - 4 700					●	●	●		40
DV 035 FHA / DH 035 FHA	1 500 - 4 700					●	●		●	42
DU 060 FHM	2 700 - 38 500					●	●	●		44
<b>Brake Calipers spring activated – electromagnetically released</b>										
DH 012 FEM	94 - 310						●	●		46
DV 020 FEM	180 - 570					●		●		47
EV 018 FEM / EH 018 FEM	65 - 360					●	●	●		48
EV 024 FEM / EH 024 FEM	320 - 1 160					●	●	●		50
EV 028 FEM / EH 028 FEM	660 - 2 580					●	●	●		52
EV 038 FEM / EH 038 FEM	2 830 - 6 590					●	●	●		54
<b>Brake Calipers spring activated – manually released</b>										
DV 020 FKM / DH 020 FKM	160 - 510					●	●	●		56
<b>Brake Calipers pneumatically activated – spring released</b>										
DH 005 PFK	0,5 - 15						●			59
DH 010 PFK	3 - 80						●			60
DH 015 PFK	17 - 430						●			61
DV 020 PFK / DH 020 PFK	25 - 650					●	●			62
DH 025 PFM	55 - 2 250						●	●		64
DV 030 PFM / DH 030 PFM	55 - 2 600					●	●	●		66
DV 035 PFM / DH 035 PFM	89 - 5 100					●	●	●		70
DU 060 PFM	371 - 23 000					●	●	●		74
<b>Brake Calipers electromagnetically activated – spring released</b>										
EV 018 EFM / EH 018 EFM	60 - 370					●	●	●		76
EV 024 EFM / EH 024 EFM	320 - 1 270					●	●	●		78
EV 028 EFM / EH 028 EFM	700 - 3 220					●	●	●		80
EV 038 EFM / EH 038 EFM	3 400 - 7 910					●	●	●		82
<b>Brake Calipers manually activated – manually released</b>										
DH 010 MSM	20 - 75						●	●		85
DV 020 MSM / DH 020 MSM	160 - 520					●	●	●		86
DV 020 MKM / DH 020 MKM	20 - 600					●	●	●		88

\* The braking torques relate to the standard brake discs shown in this catalogue. Higher braking torques are possible by the use of several brake calipers or larger brake disc diameters.

Type	Braking torque* [Nm]					Type of mounting brake at machine		Adjustment in case of friction block wear		Page
	10 <sup>2</sup>	10 <sup>3</sup>	10 <sup>4</sup>	10 <sup>5</sup>	10 <sup>6</sup>	Parallel to brake disc	At right angles to brake disc	Manual	Auto- matic	
<b>Brake Calipers spring activated – hydraulically released</b>										
HS 075 FHM	1 500 - 40 500					●		●		90
HW 075 FHM	1 500 - 40 500					●		●		92
HS 120 FHM	8 400 - 182 400					●		●		94
HW 120 FHM	8 400 - 182 400					●		●		96
<b>Brake Calipers hydraulically activated – non-releasing</b>										
HI 150 HUK	10 580 - 226 000					●				98
HW 150 HUK	10 580 - 226 000					●				100
HI 180 HUK	15 230 - 325 000					●				98
HW 180 HUK	15 230 - 325 000					●				100
<b>Brake Calipers hydraulically activated – spring released</b>										
HW 040 HFA	84 - 1 200					●			●	102
HW 063 HFA	320 - 4 700					●			●	103
HS 075 HFK	740 - 40 500					●				104
HW 075 HFK	740 - 40 500					●				106
HW 100 HFA	1 300 - 18 400					●			●	108
HS 120 HFK	4 400 - 93 500					●				110
HW 120 HFK	4 400 - 93 500					●				112
HW 150 HFA	7 200 - 106 500					●			●	114
HW 180 HFA	10 000 - 153 500					●			●	114
<b>Clamping Units spring activated – hydraulically or pneumatically released</b>										
KE ... FHK										128
KE ... FPK										130
<b>Brake Calipers Accessories</b>										
										Page
Brake Discs										116
Friction Block Wear Control										120
Universal Transformer										120
RCS® Pull Cable										121
RCS® Hand Brake Lever										121
Control System BCS 600										122
Hydraulic power unit										126
Pneumatic Cabinet										126
<b>Brake Technology Details</b>										
										Page
Technical Points Brake Discs										119
Technical Points Brake Calipers										132
Technical Points Clamping Units										133
Questionnaire for selecting Brake Calipers										134
Questionnaire for selecting Clamping Units										135

\* The braking torques relate to the standard brake discs shown in this catalogue. Higher braking torques are possible by the use of several brake calipers or larger brake disc diameters.  
Issue 05/2016 • Technical details subject to change without notice.

# Design and Function of Brakes

## No Drives without Disc Brakes

For a long time now Disc Brakes have been tried and tested in the aviation and automotive industry, and increasing awareness of operatio-

nal safety and ever stricter rules on accident prevention have made them indispensable. After all, wherever there is acceleration, there

must also be braking. A reliable and economic solution to these problems are RINGSPANN Disc Brakes.

## Advantages of RINGSPANN Disc Brakes

The following features make the RINGSPANN Disc Brakes unique:

- The well thought-out design of RINGSPANN Disc Brakes permits a **simple and space-saving arrangement**, even in existing installations.
- Due to the even friction surfaces the RINGSPANN Disc Brakes are not subject to any automatic amplification effect which is always a problem with drum brakes. Therefore, disc brakes guarantee **high torque stability** even when friction variations occur.

- The open design of the RINGSPANN Disc Brakes with their excellent ventilation characteristics provides **ideal heat dissipation**; this is a precondition for high braking power with a compact design.
- The considerably **lower inertia moment** compared with that of drum brakes permits economical dimensioning, shortened cycle times and reduced energy consumption.
- Highly wear-resistant friction material and large braking surfaces ensure long intervals between maintenance. The practical and robust design of RINGSPANN Disc Brakes

makes that **maintenance easy and uncomplicated**. The friction pads are easily replaced without the need to remove the brake.

- RINGSPANN Disc Brakes are fitted with **swivel mounted friction blocks**; this ensures that the friction blocks are always in full face contact with the brake disc. When the brake is released, the friction blocks are lifted safely off the disc by a spring, irrespective of the installation arrangement.

## For each Application the right Solution

RINGSPANN Disc Brakes require minimal installation space. Brake Calipers or Brake Saddles may be arranged in any position on brake discs of varying diameters. By using several Brake Calipers on the same disc it is possible to increase the braking torque without the need to enlarge the installation space.

The universal concept of the RINGSPANN Disc Brake fulfills various functions:

- **Stopping brake**
- **Control brake**
- **Holding brake**

As a **stopping brake**, it brings a rotating shaft to a standstill in a short time, for example during a power failure or an emergency stop.

As a **control brake**, it effectively maintains material tension.

As a **holding brake**, it prevents the unintended start of a stationary shaft.

## The Product Range

RINGSPANN offers a comprehensive range of Disc Brakes:

- **Spring activated Brake Calipers**; release is either pneumatic, hydraulic, electromagnetic or manual by means of a pull cable.

- **Pneumatically activated Brake Calipers**; spring released

- **Manually activated Brake Calipers**; manually released with a hand wheel or a pull cable

- **Hydraulically activated Brake Calipers**; spring released

- **Spring activated Clamping Unit**; hydraulically or pneumatically released

## Accessories

Accessories are available for special applications:

- Two standard types of **brake discs** are available with diameters ranging from 125 mm up to 1 000 mm
- All brakes can be supplied with an **electric indicator for friction block wear**
- Inductive proximity switches for **monitoring the operating condition** "brake released" are available

- To prolong the operating life, **friction blocks with double the friction surface** are available for Brake Calipers sizes 12, 15, 20 and 30

- **Special friction linings** are available for special requirements





DH 010 FPM



DV 020 FPM /  
DH 020 FPM



DH 025 FPM



DH 025 FPA



DV 030 FPM /  
DH 030 FPM



DV 030 FPA /  
DH 030 FPA



DV 035 FPM /  
DH 035 FPM



DV 035 FPA /  
DH 035 FPA



DU 060 FPM



DV 020 FHM /  
DH 020 FHM



DV 030 FHM /  
DH 030 FHM



DV 030 FHA /  
DH 030 FHA



DV 035 FHM /  
DH 035 FHM



DV 035 FHA /  
DH 035 FHA



DU 060 FHM



DH 012 FEM



DV 020 FEM



EV 018 FEM /  
EH 018 FEM



EV 024 FEM /  
EH 024 FEM



EV 028 FEM /  
EH 028 FEM



EV 038 FEM /  
EH 038 FEM



DV 020 FKM /  
DH 020 FKM



DH 005 PFK



DH 010 PFK



DH 015 PFK



DV 020 PFK /  
DH 020 PFK



DH 025 PFM



DV 030 PFM /  
DH 030 PFM



DV 035 PFM /  
DH 035 PFM



DU 060 PFM



EV 018 EFM /  
EH 018 EFM



EV 024 EFM /  
EH 024 EFM



EV 028 EFM /  
EH 028 EFM



EV 038 EFM /  
EH 038 EFM



DH 010 MSM



DV 020 MSM /  
DH 020 MSM



DV 020 MKM /  
DH 020 MKM



HS 075 FHM



HW 075 FHM



HS 120 FHM



HW 120 FHM



HI 150 HUK /  
HI 180 HUK



HW 150 HUK /  
HW 180 HUK



HW 040 HFA



HW 063 HFA



HS 075 HFK



HW 075 HFK



HW 100 HFA



HS 120 HFK



HW 120 HFK



HW 150 HFA /  
HW 180 HFA

# Areas of Application for Brakes

**Amusement rides**

**Assembly stations**

**Belt conveyors**

**Construction machines**

**Conveyors**

**Cranes**

**Elevators and escalators**

**Extruder, machines for rubber and plastics**

**Fans and ventilators**

**Foundry machines**

**Machines for food industry**

**Packaging machines**

**Paper machines**

**Printing machines**

**Ship drives**

**Shredders**

**Steel mills**

**Stranding lines**

**Test benches**

**Textile machines**

**Wind turbines**

**Wire and tube machines**

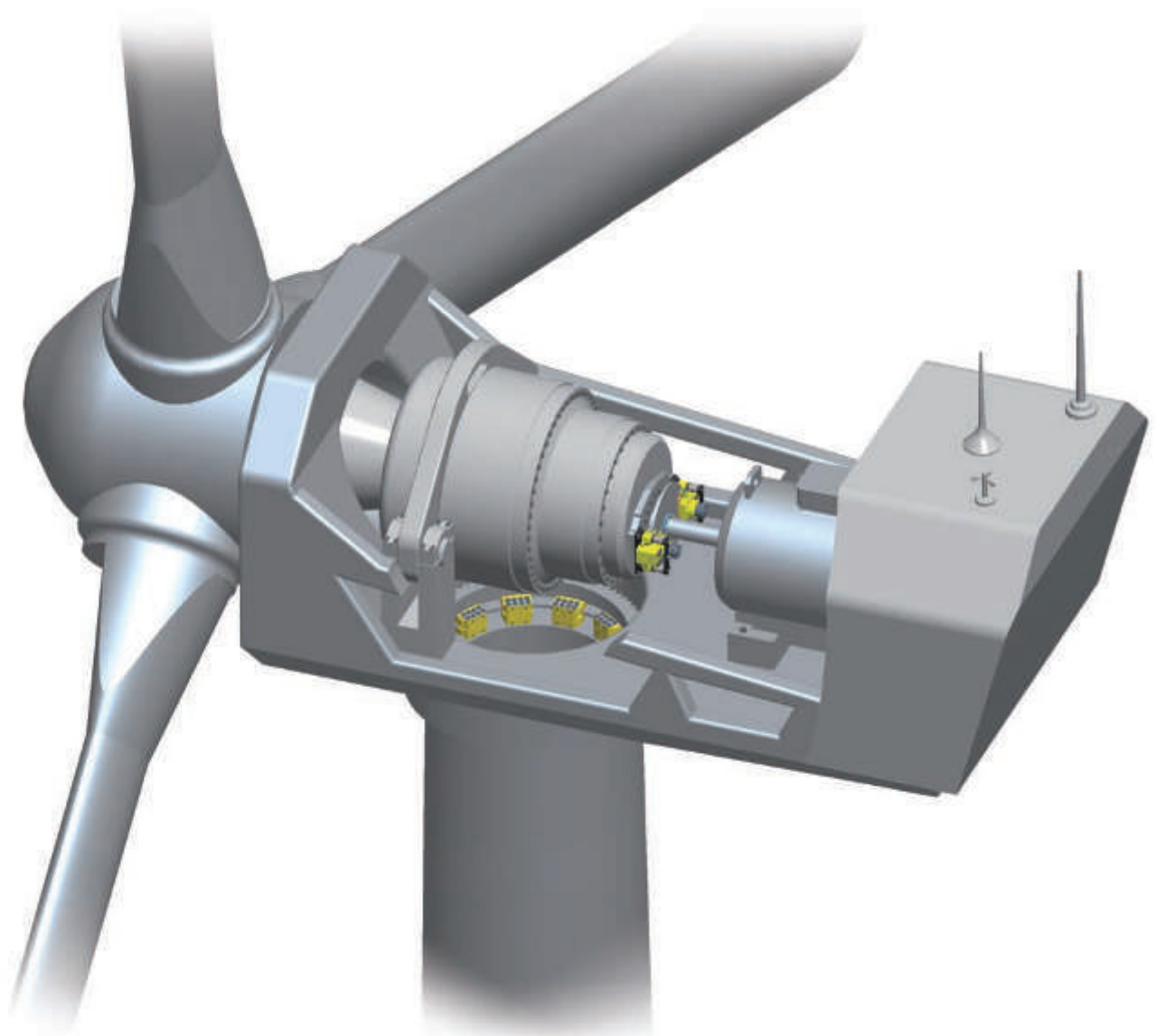

**Wind turbines**

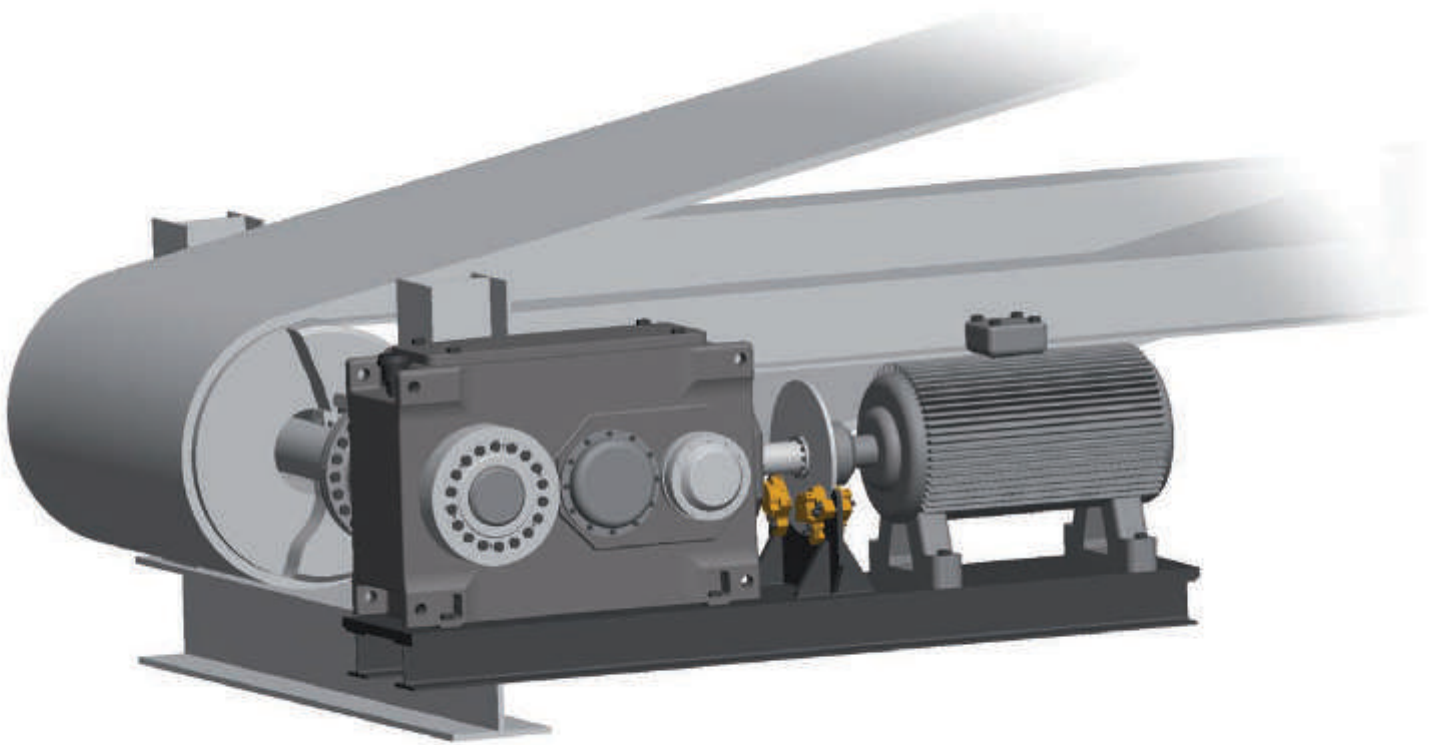

**Belt conveyors**

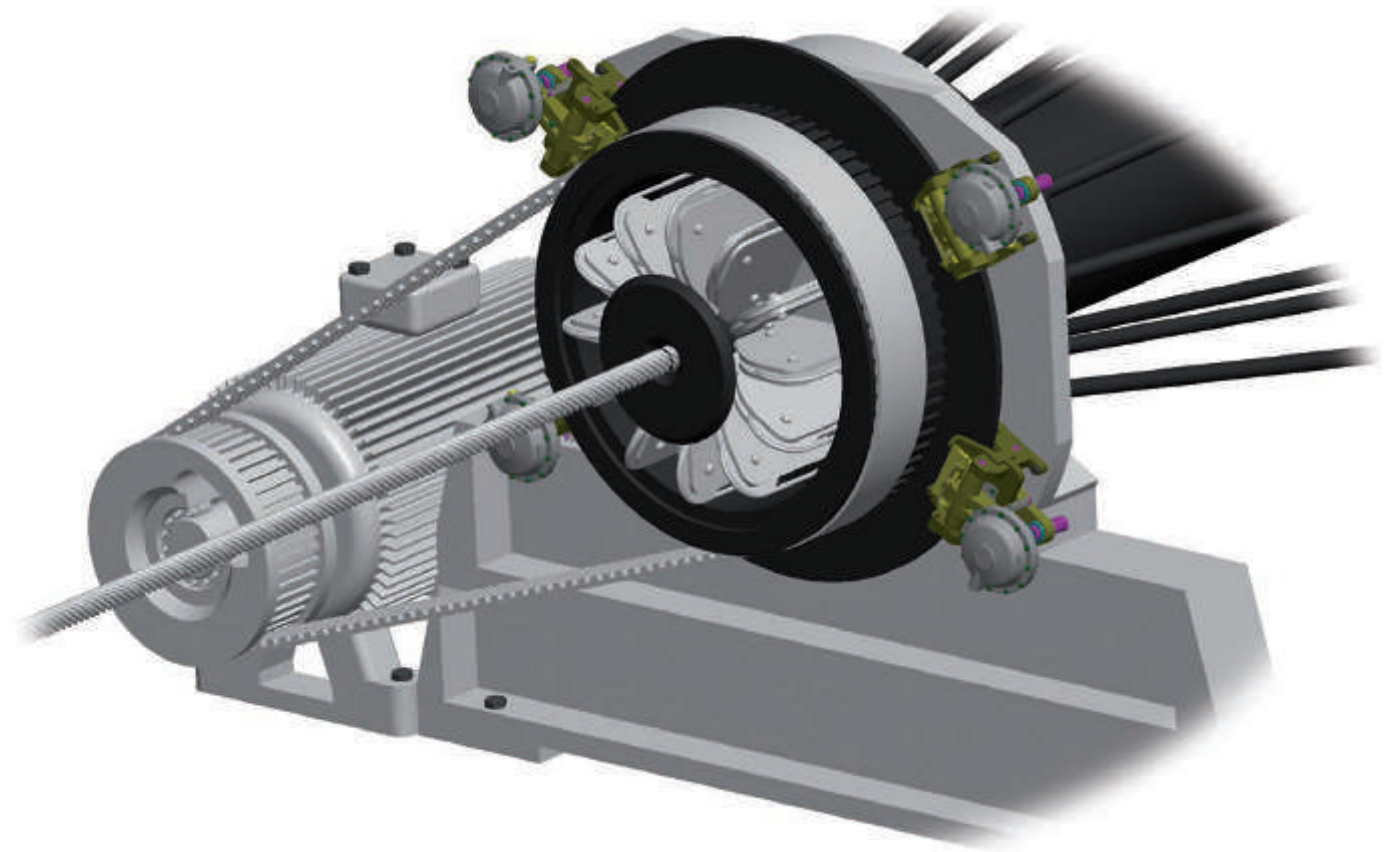

**Stranding lines**



# Brake Caliper DH 010 FPM

spring activated – pneumatically released



## Features

Features	Code
Brake Caliper	D
Mounting to the machine at right angles to the brake disc	H
Frame size 010	010
Spring activated	F
Pneumatically released	P
Manual adjustment to accommodate friction block wear	M
Designs 010 or 012 are available	010 012
Piston mounted in central position	M
Thickness of brake disc 12,5 mm	12

## Example for ordering

Brake Caliper DH 010 FPM, design 010, piston mounted in central position, thickness of brake disc 12,5 mm:

DH 010 FPM - 010 M - 12

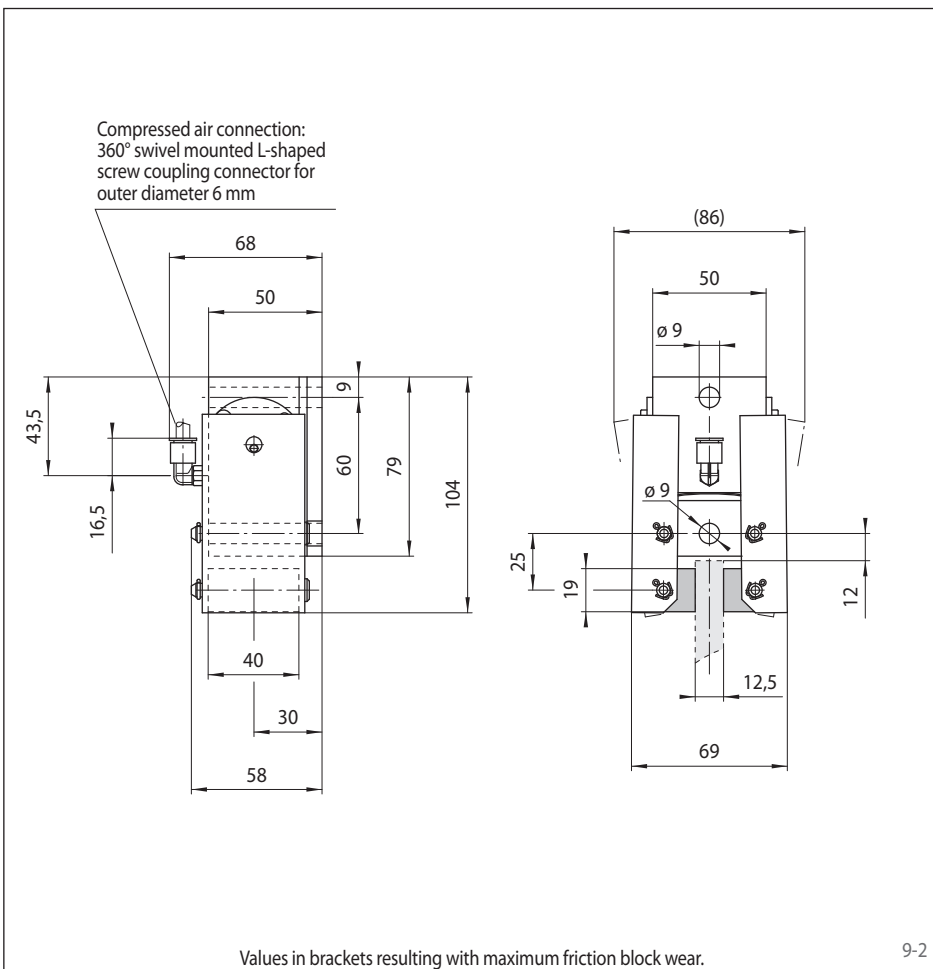

## Technical Data

Brake disc diameter	Brake Caliper DH 010 FPM	
	with design 010	with design 012
mm	Braking torque Nm	Braking torque Nm
125	10	15
150	14	19
200	20	26
250	26	34
300	32	41
355	38	50
Clamping force	290 N	375 N
Air pressure	min. 4 bar max. 8 bar	min. 5 bar max. 8 bar
Air volume per activation	max. 3 cm <sup>3</sup>	max. 3 cm <sup>3</sup>
Weight	1 kg	1 kg

The braking torques shown in the table are based on a theoretical friction coefficient of 0,4.



# Brake Caliper DV 020 FPM

spring activated – pneumatically released

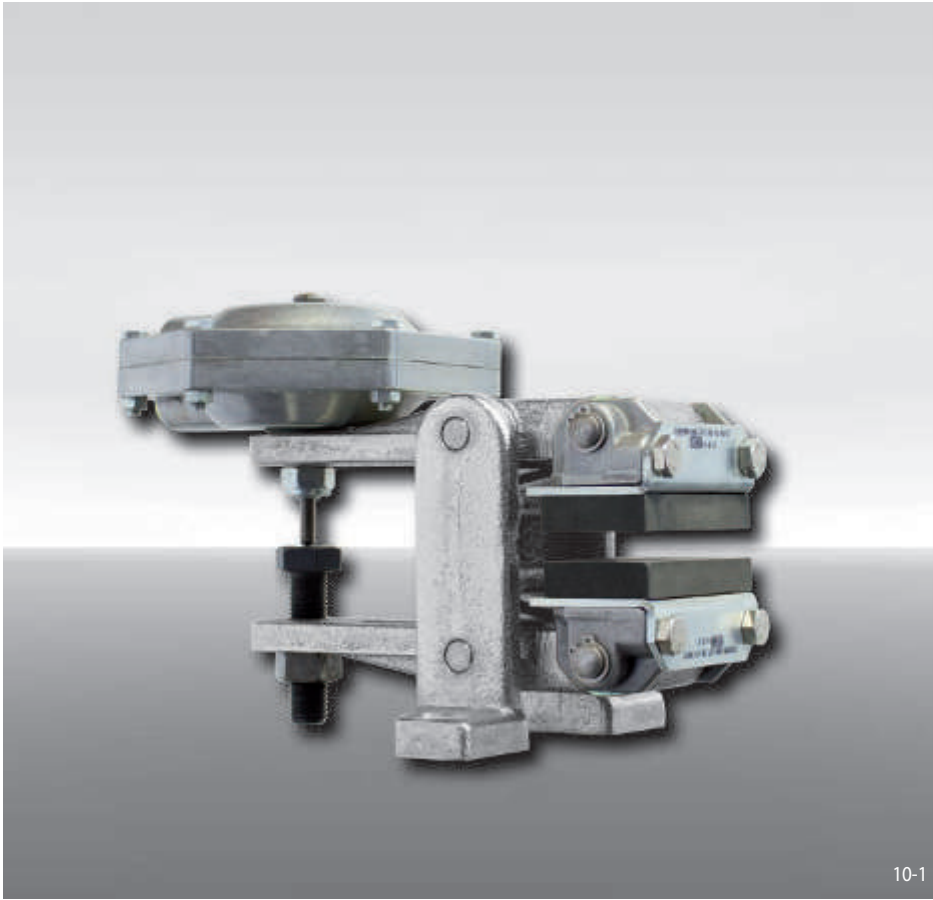

10-1

## Features

Features	Code
Brake Caliper	D
Mounting to the machine parallel to the brake disc	V
Frame size 020	020
Spring activated	F
Pneumatically released	P
Manual adjustment to accommodate friction block wear	M
Thrusters 020, 030 or 040 are available	020 030 040
Thruster mounted right or left available	R L
Thickness of brake disc 12,5 mm	12

## Example for ordering

Brake Caliper DV 020 FPM, thruster 020, thruster mounted right, thickness of brake disc 12,5 mm:

DV 020 FPM - 020 R - 12

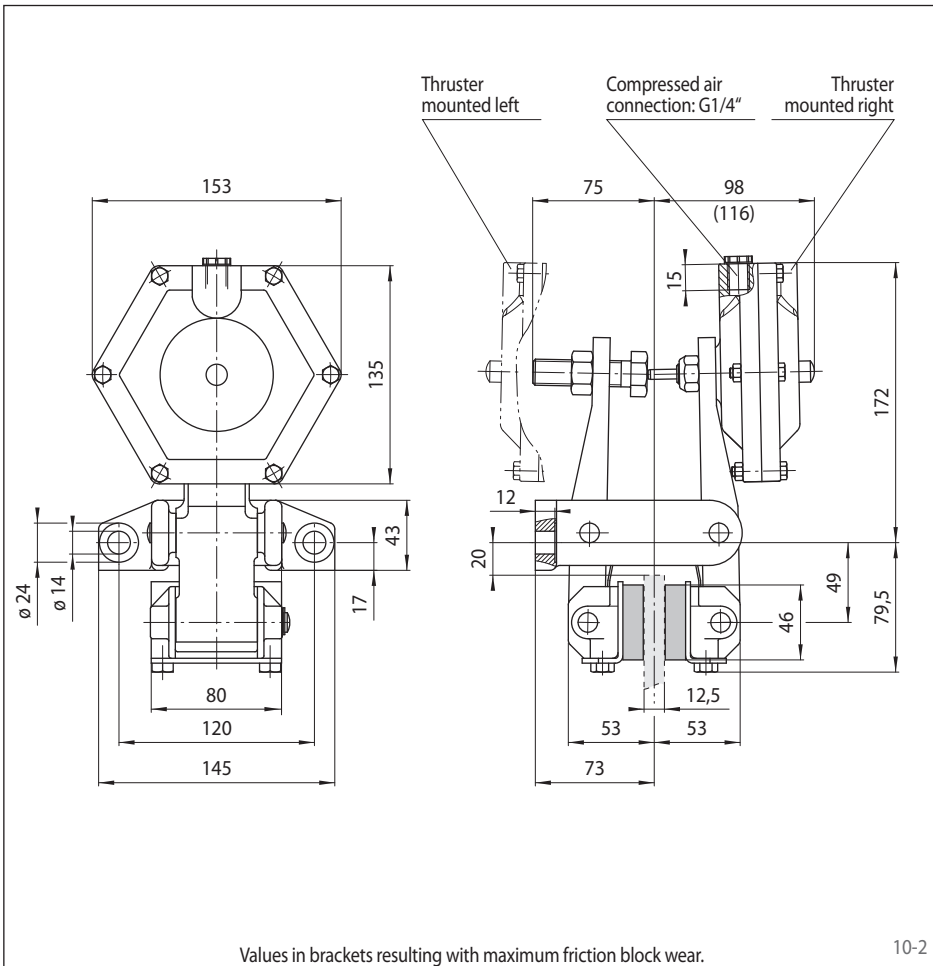

Values in brackets resulting with maximum friction block wear.

10-2

## Technical Data

Brake disc diameter	Brake Caliper DV 020 FPM		
	with thruster 020	with thruster 030	with thruster 040
mm	Braking torque Nm	Braking torque Nm	Braking torque Nm
200	97	130	200
250	130	180	270
300	170	220	340
355	200	270	420
430	250	340	520
520	310	430	650
Clamping force	1700 N	2300 N	3500 N
Air pressure	min. 2,6 bar max. 7 bar	min. 3,5 bar max. 7 bar	min. 5 bar max. 7 bar
Air volume per activation	max. 17 cm <sup>3</sup>	max. 17 cm <sup>3</sup>	max. 17 cm <sup>3</sup>
Weight	5,2 kg	5,2 kg	5,2 kg

The braking torques shown in the table are based on a theoretical friction coefficient of 0,4.



# Brake Caliper DH 020 FPM

spring activated – pneumatically released



11-1

## Features

Features	Code
Brake Caliper	D
Mounting to the machine at right angles to the brake disc	H
Frame size 020	020
Spring activated	F
Pneumatically released	P
Manual adjustment to accommodate friction block wear	M
Thrusters 020, 030 or 040 are available	020 030 040
Position of the thruster to the right or left can be defined by turning the brake during installation	U
Thickness of brake disc 12,5 mm	12

## Example for ordering

Brake Caliper DH 020 FPM, thruster 020, position of the thruster can be to the right or left, thickness of brake disc 12,5 mm:

DH 020 FPM - 020 U - 12

## Technical Data

	Brake Caliper DH 020 FPM		
	with thruster 020	with thruster 030	with thruster 040
Brake disc diameter	Braking torque	Braking torque	Braking torque
mm	Nm	Nm	Nm
200	97	130	200
250	130	180	270
300	170	220	340
355	200	270	420
430	250	340	520
520	310	430	650
Clamping force	1 700 N	2 300 N	3 500 N
Air pressure	min. 2,6 bar max. 7 bar	min. 3,5 bar max. 7 bar	min. 5 bar max. 7 bar
Air volume per activation	max. 17 cm <sup>3</sup>	max. 17 cm <sup>3</sup>	max. 17 cm <sup>3</sup>
Weight	5,2 kg	5,2 kg	5,2 kg

The braking torques shown in the table are based on a theoretical friction coefficient of 0,4.

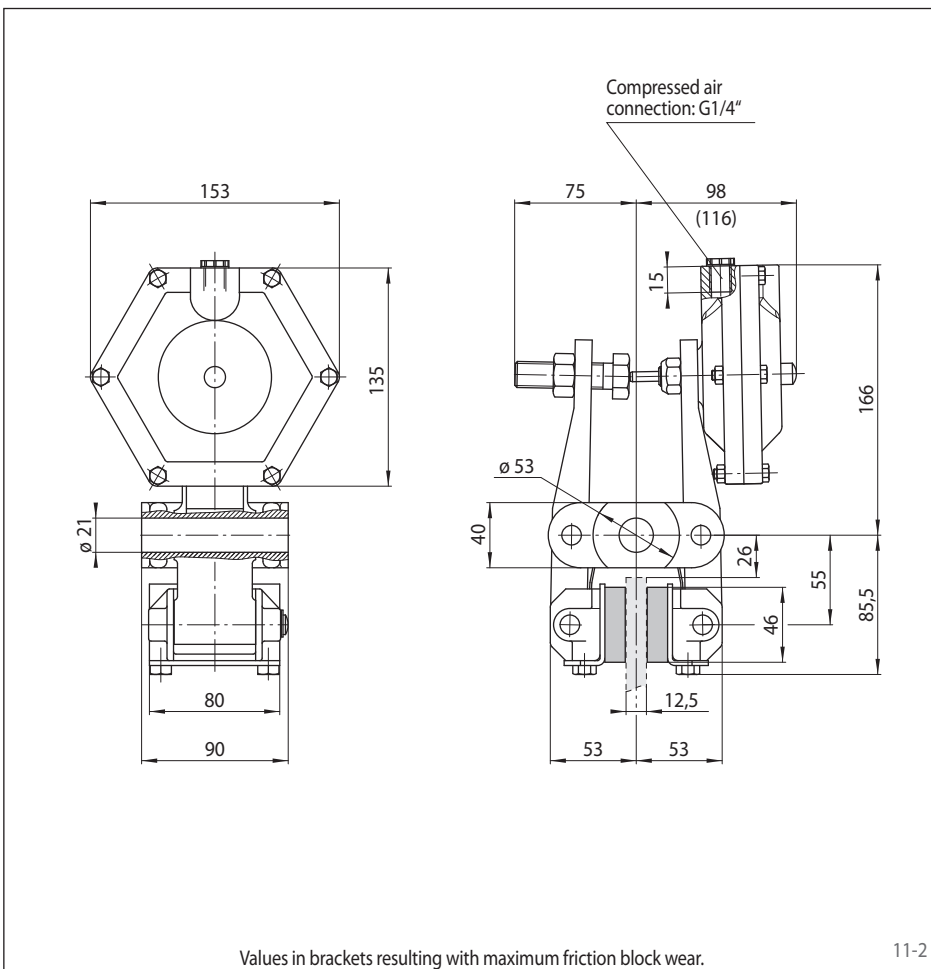

Values in brackets resulting with maximum friction block wear.

11-2

# Brake Caliper DH 025 FPM

spring activated – pneumatically released

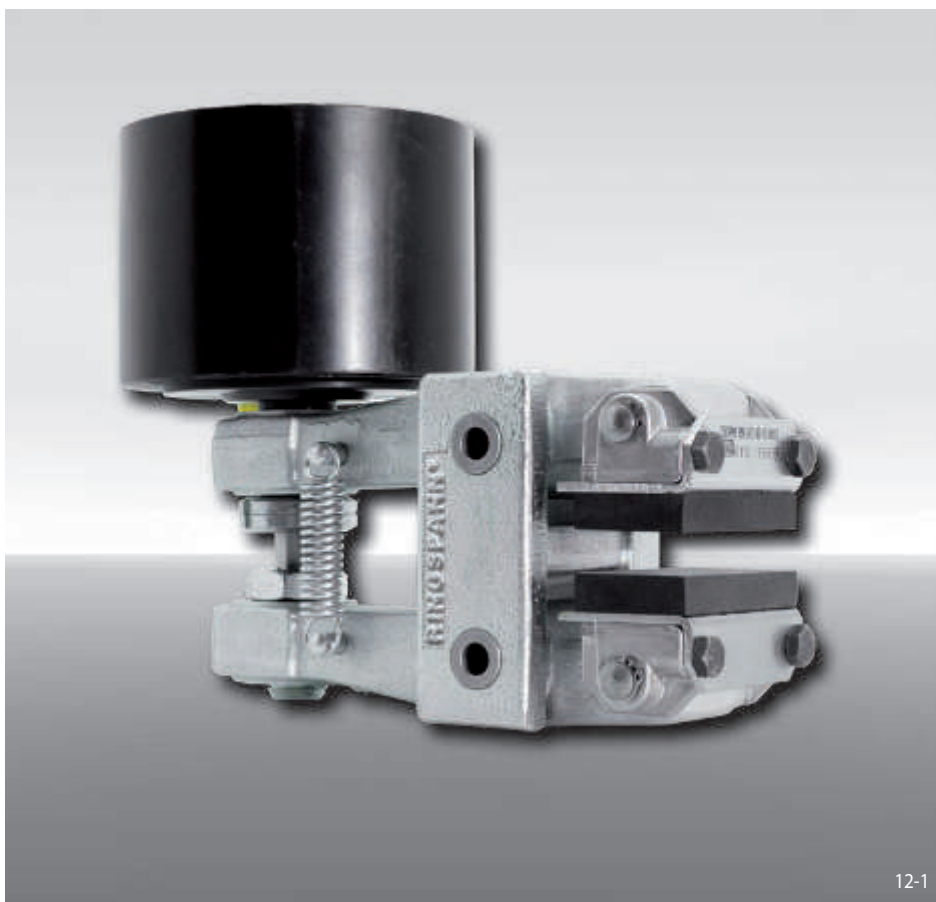

12-1

## Features

Features	Code
Brake Caliper	D
Mounting to the machine at right angles to the brake disc	H
Frame size 025	025
Spring activated	F
Pneumatically released	P
Manual adjustment to accommodate friction block wear	M
Thrusters 015, 025, 035 or 045 are available	015 to 045
Thruster mounted right or left available	R L
Thickness of brake disc 12,5 mm or 25 mm	12 25

## Example for ordering

Brake Caliper DH 025 FPM, thruster 015, thruster mounted right, thickness of brake disc 12,5 mm:

DH 025 FPM - 015 R - 12

## Technical Data

	Brake Caliper DH 025 FPM			
	with thruster 015	with thruster 025	with thruster 035	with thruster 045
Brake disc diameter	Braking torque	Braking torque	Braking torque	Braking torque
mm	Nm	Nm	Nm	Nm
200	240	270	400	570
250	330	370	540	770
300	420	460	680	970
355	510	570	840	1200
430	640	710	1050	1500
520	790	890	1300	1900
Clamping force	4300 N	4800 N	7100 N	10100 N
Air pressure	min. 5 bar max. 7 bar	min. 5 bar max. 8 bar	min. 4,2 bar max. 8 bar	min. 5 bar max. 8 bar
Air volume per activation	max. 17 cm <sup>3</sup>	max. 120 cm <sup>3</sup>	max. 185 cm <sup>3</sup>	max. 185 cm <sup>3</sup>
Weight	7,5 kg	8,6 kg	10,9 kg	11,0 kg

The braking torques shown in the table are based on a theoretical friction coefficient of 0,4.

# Brake Caliper DH 025 FPM

spring activated – pneumatically released

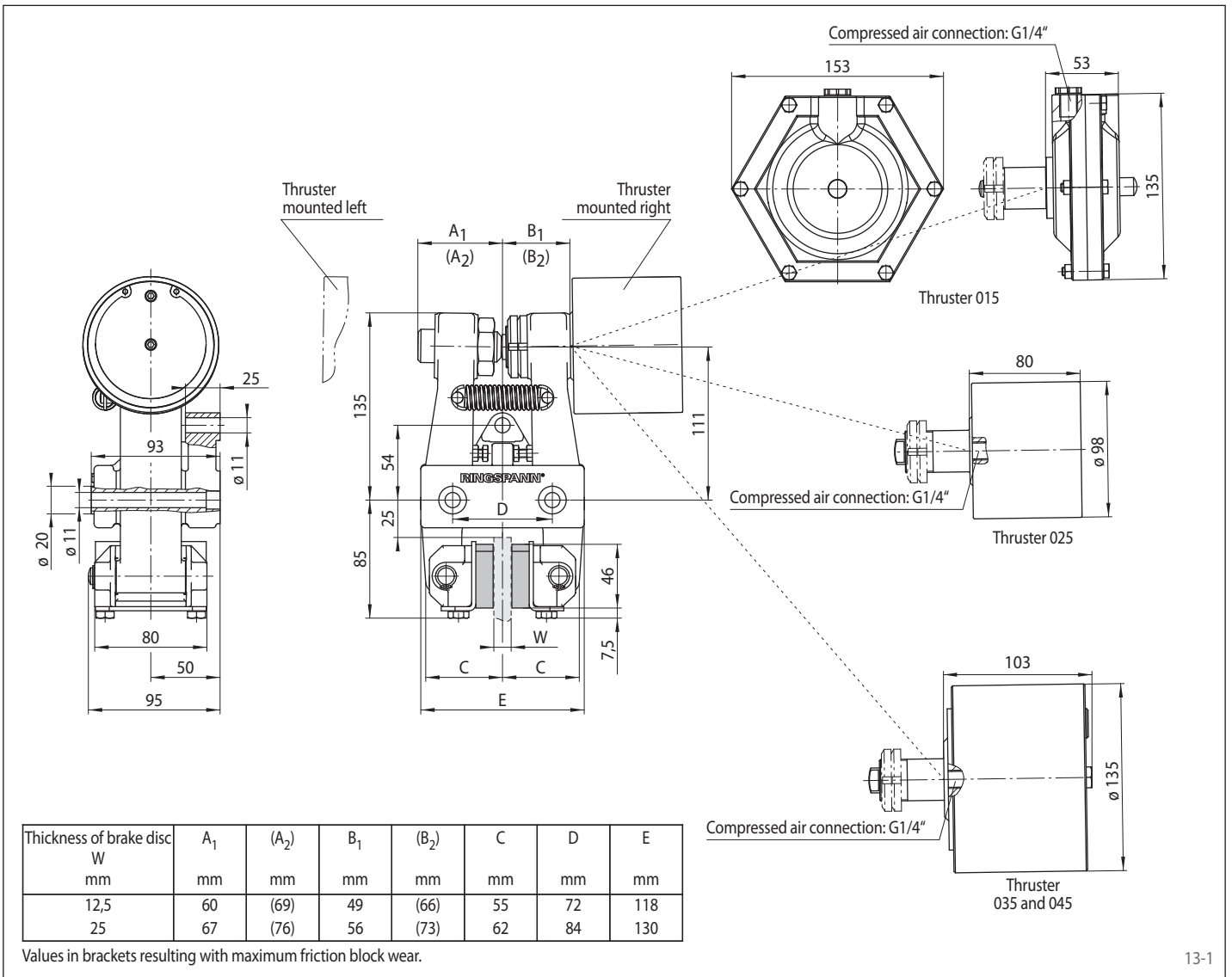

# Brake Caliper DH 025 FPA

spring activated – pneumatically released

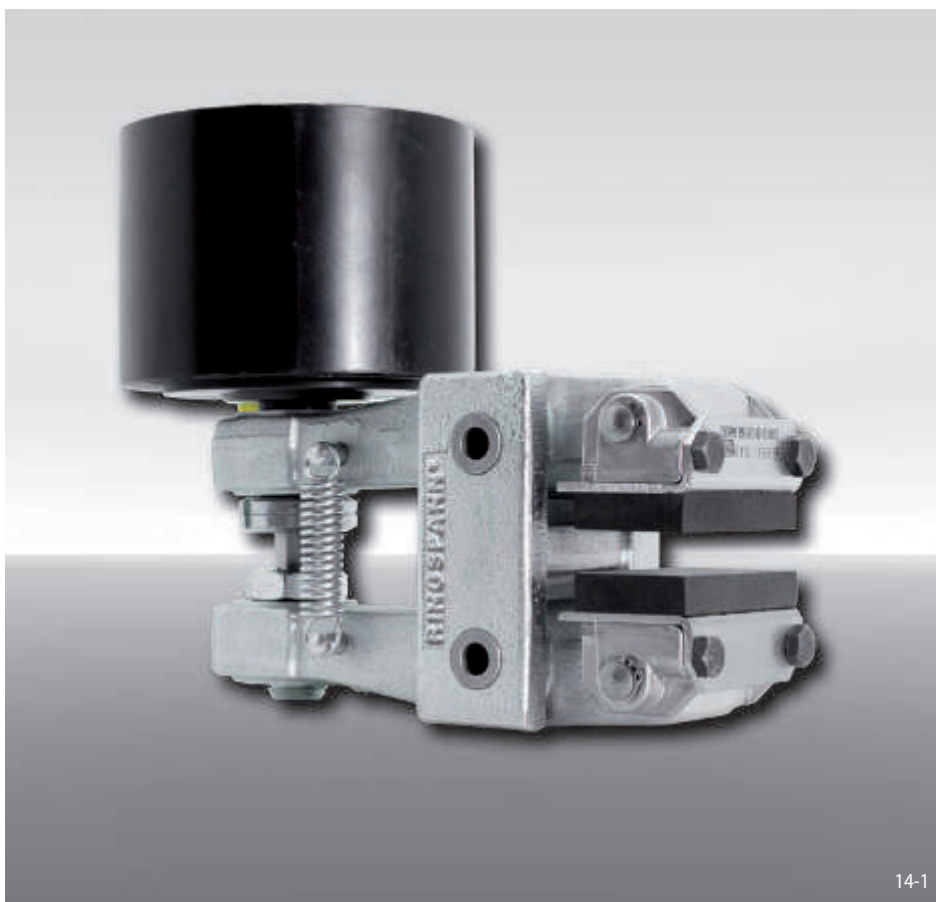

Features	Code
Brake Caliper	D
Mounting to the machine at right angles to the brake disc	H
Frame size 025	025
Spring activated	F
Pneumatically released	P
Automatic adjustment to accommodate friction block wear	A
Thrusters 065, 085 or 095 are available	065 to 095
Thruster mounted right or left available	R L
Thickness of brake disc 12,5 mm or 25 mm	12 25

### Example for ordering

Brake Caliper DH 025 FPA, thruster 085, thruster mounted right, thickness of brake disc 12,5 mm:

DH 025 FPA - 085 R - 12

### Technical Data

	Brake Caliper DH 025 FPA		
	with thruster 065	with thruster 085	with thruster 095
Brake disc diameter	Braking torque	Braking torque	Braking torque
mm	Nm	Nm	Nm
200	250	150	530
250	340	200	710
300	430	250	900
355	530	310	1 100
430	670	390	1 400
520	830	480	1 700
Clamping force	4 500 N	2 600 N	9 300 N
Air pressure	min. 5 bar max. 8 bar	min. 1,7 bar max. 8 bar	min. 5 bar max. 8 bar
Air volume per activation	max. 72 cm <sup>3</sup>	max. 140 cm <sup>3</sup>	max. 140 cm <sup>3</sup>
Weight	8,9 kg	11,2 kg	11,2 kg

The braking torques shown in the table are based on a theoretical friction coefficient of 0,4.

# Brake Caliper DH 025 FPA

spring activated – pneumatically released

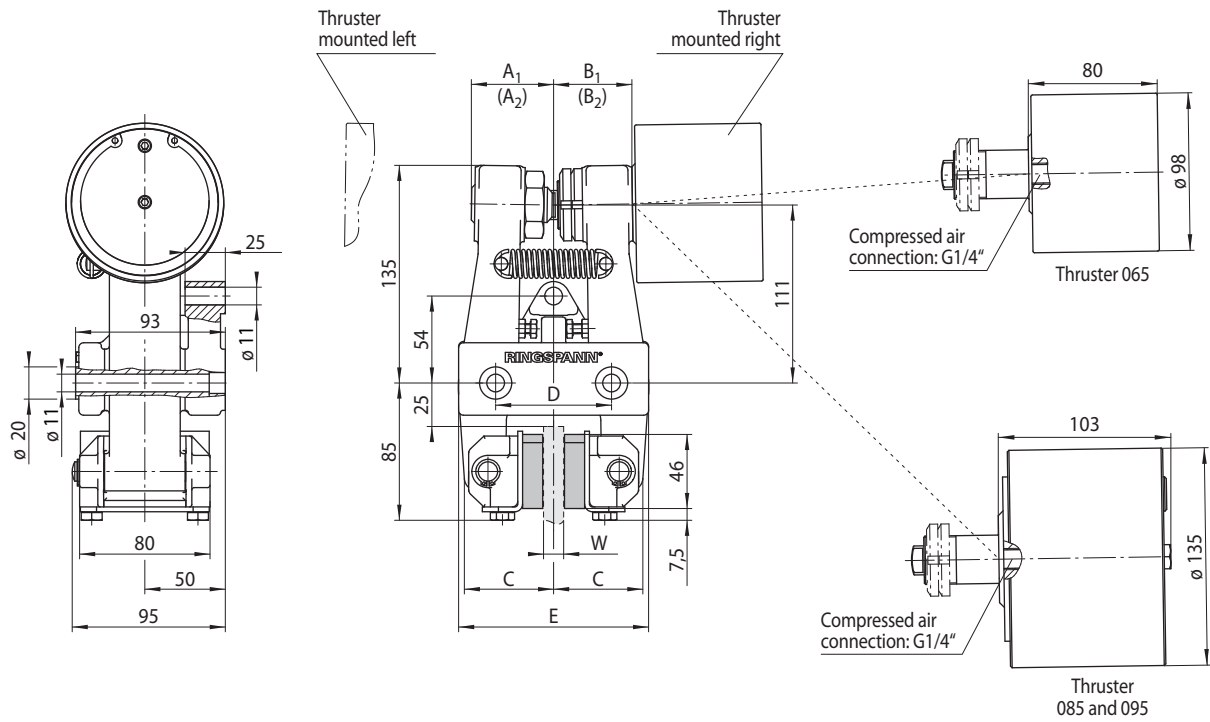

Thickness of brake disc W mm	A <sub>1</sub> mm	(A <sub>2</sub> ) mm	B <sub>1</sub> mm	(B <sub>2</sub> ) mm	C mm	D mm	E mm
12,5	51	(69)	49	(66)	55	72	118
25	57	(76)	56	(73)	62	84	130

Values in brackets resulting with maximum friction block wear.

# Brake Caliper DV 030 FPM

spring activated – pneumatically released

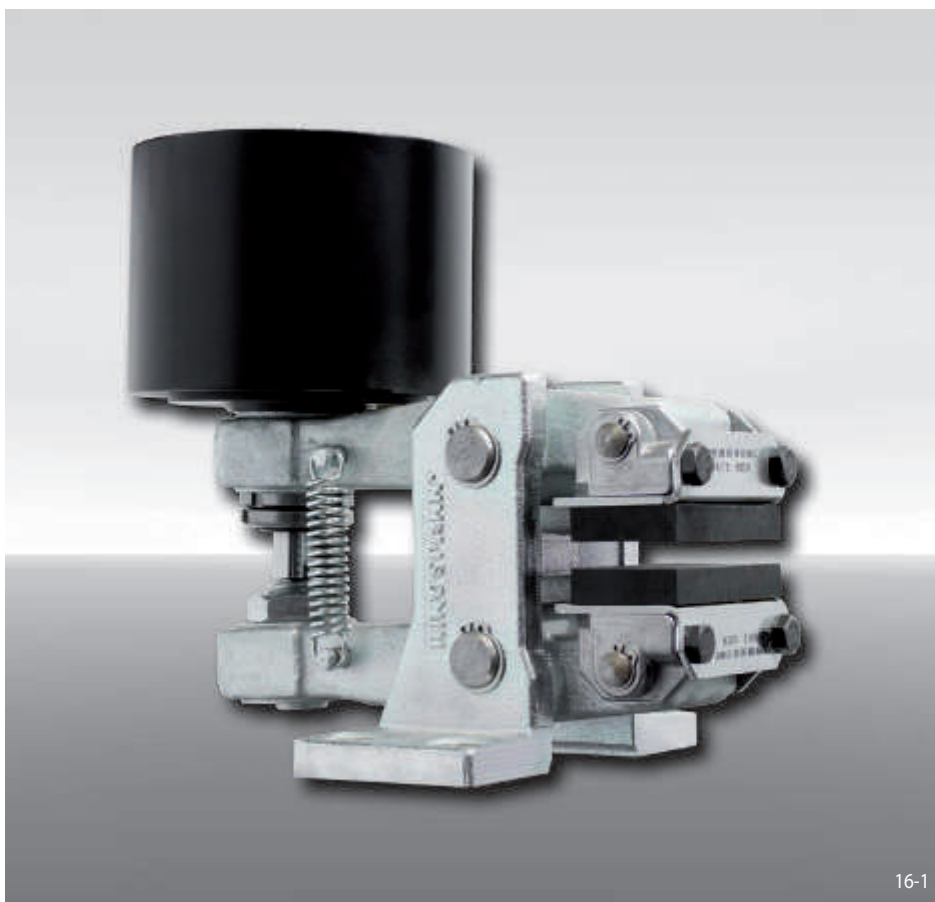

16-1

Features	Code
Brake Caliper	D
Mounting to the machine parallel to the brake disc	V
Frame size 030	030
Spring activated	F
Pneumatically released	P
Manual adjustment to accommodate friction block wear	M
Thrusters 025, 035, 045 or 101 are available	025 to 101
Thruster mounted right or left available	R L
Thickness of brake disc 12,5 mm or 25 mm	12 25

### Example for ordering

Brake Caliper DV 030 FPM, thruster 035, thruster mounted right, thickness of brake disc 12,5 mm:

DV 030 FPM - 035 R - 12

### Technical Data

	Brake Caliper DV 030 FPM			
	with thruster 025	with thruster 035	with thruster 045	with thruster 101
Brake disc diameter	Braking torque	Braking torque	Braking torque	Braking torque
mm	Nm	Nm	Nm	Nm
200	270	400	570	760
250	370	540	770	1050
300	460	680	970	1300
355	570	840	1200	1600
430	710	1050	1500	2000
520	890	1300	1900	2500
Arrangement	right / left	right / left	right / left	right
Clamping force	4800 N	7100 N	10100 N	13500 N
Air pressure	min. 5 bar max. 8 bar	min. 4,2 bar max. 8 bar	min. 5 bar max. 8 bar	min. 4,5 bar max. 8 bar
Air volume per activation	max. 120 cm <sup>3</sup>	max. 185 cm <sup>3</sup>	max. 185 cm <sup>3</sup>	max. 540 cm <sup>3</sup>
Weight	9,1 kg	11,2 kg	11,2 kg	12,4 kg

The braking torques shown in the table are based on a theoretical friction coefficient of 0,4.



# Brake Caliper DV 030 FPM

spring activated – pneumatically released

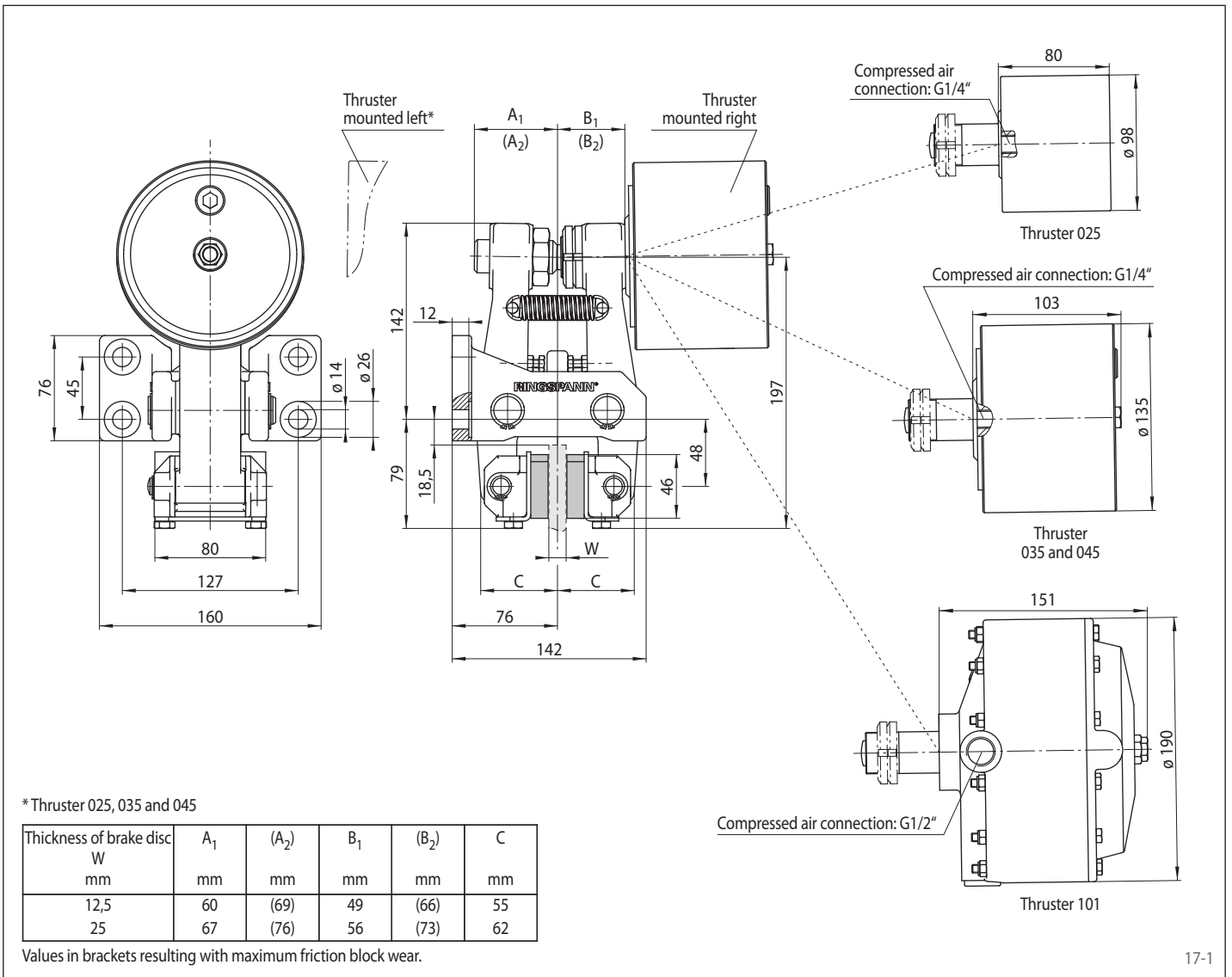

# Brake Caliper DH 030 FPM

spring activated – pneumatically released

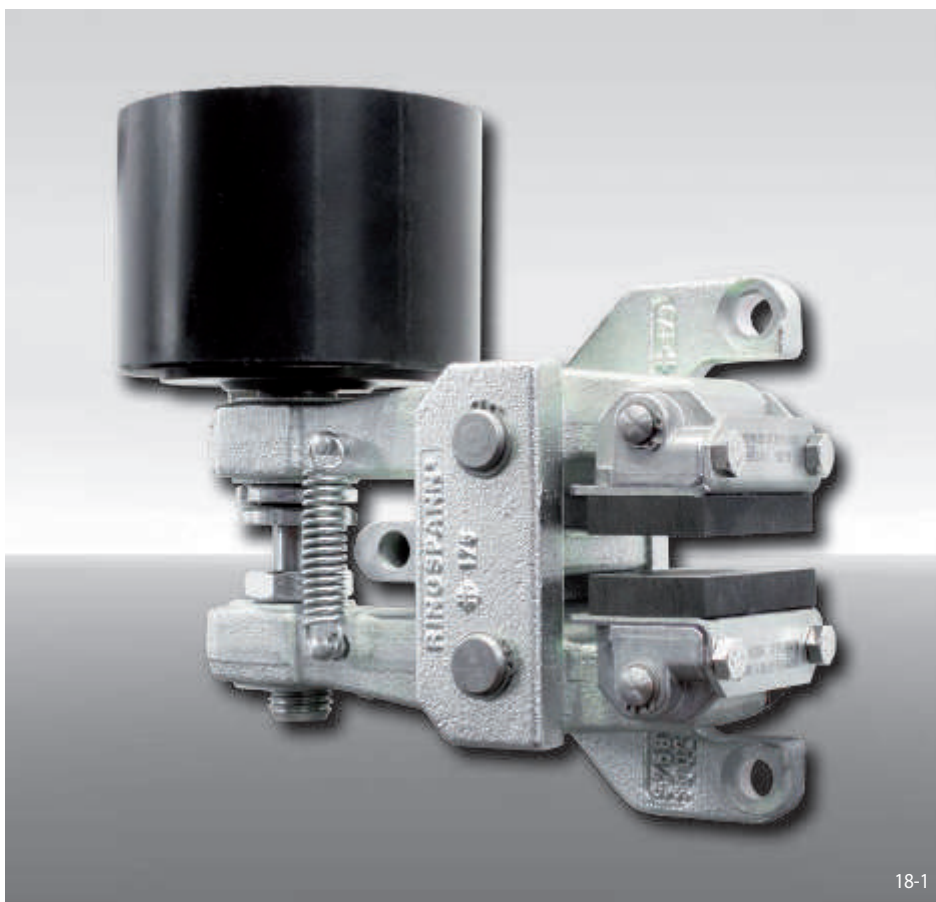

## Features

Features	Code
Brake Caliper	D
Mounting to the machine at right angles to the brake disc	H
Frame size 030	030
Spring activated	F
Pneumatically released	P
Manual adjustment to accommodate friction block wear	M
Thrusters 025, 035, 045 or 101 are available	025 to 101
Thruster mounted right or left available	R L
Thickness of brake disc 12,5 mm or 25 mm	12 25

## Example for ordering

Brake Caliper DH 030 FPM, thruster 035, thruster mounted right, thickness of brake disc 12,5 mm:

DH 030 FPM - 035 R - 12

## Technical Data

	Brake Caliper DH 030 FPM			
	with thruster 025	with thruster 035	with thruster 045	with thruster 101
Brake disc diameter	Braking torque	Braking torque	Braking torque	Braking torque
mm	Nm	Nm	Nm	Nm
200	270	400	570	760
250	370	540	770	1050
300	460	680	970	1300
355	570	840	1200	1600
430	710	1050	1500	2000
520	890	1300	1900	2500
Clamping force	4800 N	7100 N	10100 N	13500 N
Air pressure	min. 5 bar max. 8 bar	min. 4,2 bar max. 8 bar	min. 5 bar max. 8 bar	min. 4,5 bar max. 8 bar
Air volume per activation	max. 120 cm <sup>3</sup>	max. 185 cm <sup>3</sup>	max. 185 cm <sup>3</sup>	max. 540 cm <sup>3</sup>
Weight	9,5 kg	11,6 kg	11,6 kg	12,8 kg

The braking torques shown in the table are based on a theoretical friction coefficient of 0,4

# Brake Caliper DH 030 FPM

spring activated – pneumatically released

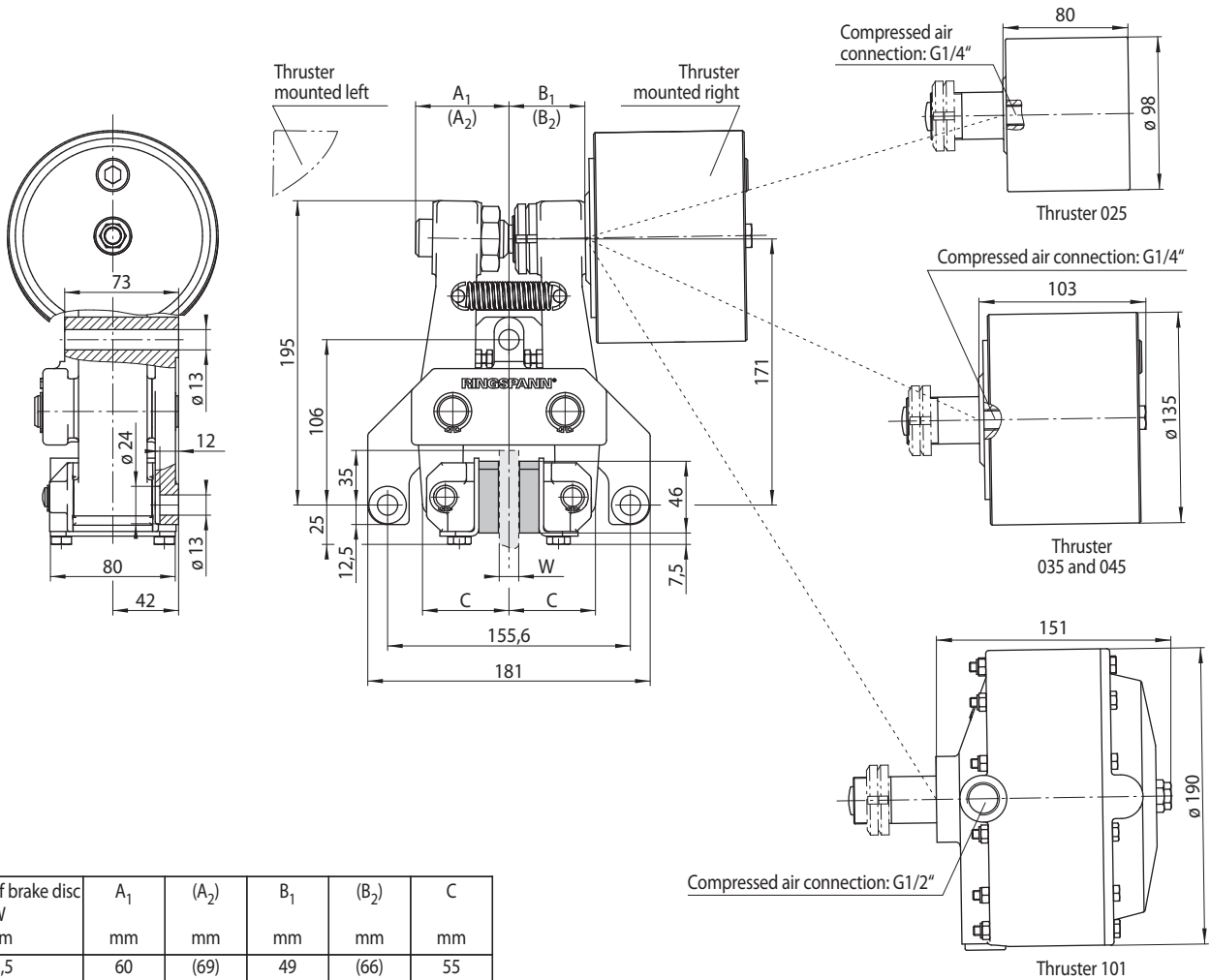

Thickness of brake disc W mm	A <sub>1</sub> mm	(A <sub>2</sub> ) mm	B <sub>1</sub> mm	(B <sub>2</sub> ) mm	C mm
12,5	60	(69)	49	(66)	55
25	67	(76)	56	(73)	62

Values in brackets resulting with maximum friction block wear.

# Brake Caliper DV 030 FPA

spring activated – pneumatically released

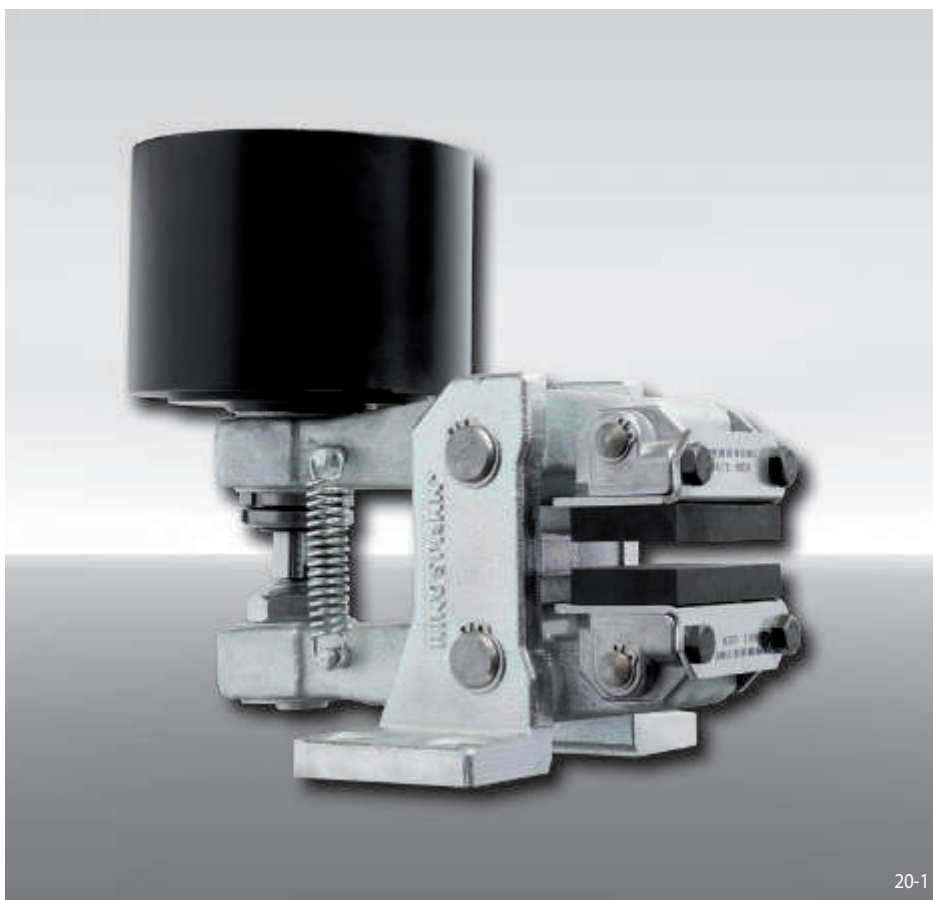

20-1

Features	Code
Brake Caliper	D
Mounting to the machine parallel to the brake disc	V
Frame size 030	030
Spring activated	F
Pneumatically released	P
Automatic adjustment to accommodate friction block wear	A
Thrusters 065, 085, 095 or 105 are available	065 to 105
Thruster mounted right or left available	R L
Thickness of brake disc 12,5 mm or 25 mm	12 25

### Example for ordering

Brake Caliper DV 030 FPA, thruster 085, thruster mounted right, thickness of brake disc 12,5 mm:

DV 030 FPA - 085 R - 12

### Technical Data

	Brake Caliper DV 030 FPA			
	with thruster 065	with thruster 085	with thruster 095	with thruster 105
Brake disc diameter	Braking torque	Braking torque	Braking torque	Braking torque
mm	Nm	Nm	Nm	Nm
200	250	150	530	760
250	340	200	710	1050
300	430	250	900	1300
355	530	310	1100	1600
430	670	390	1400	2000
520	830	480	1700	2500
Arrangement	right / left	right / left	right / left	right
Clamping force	4500 N	2600 N	9300 N	13500 N
Air pressure	min. 5 bar max. 8 bar	min. 1,7 bar max. 8 bar	min. 5 bar max. 8 bar	min. 4,7 bar max. 8 bar
Air volume per activation	max. 72 cm <sup>3</sup>	max. 140 cm <sup>3</sup>	max. 140 cm <sup>3</sup>	max. 460 cm <sup>3</sup>
Weight	9,1 kg	11,5 kg	11,5 kg	13,1 kg

The braking torques shown in the table are based on a theoretical friction coefficient of 0,4.

# Brake Caliper DV 030 FPA

spring activated – pneumatically released

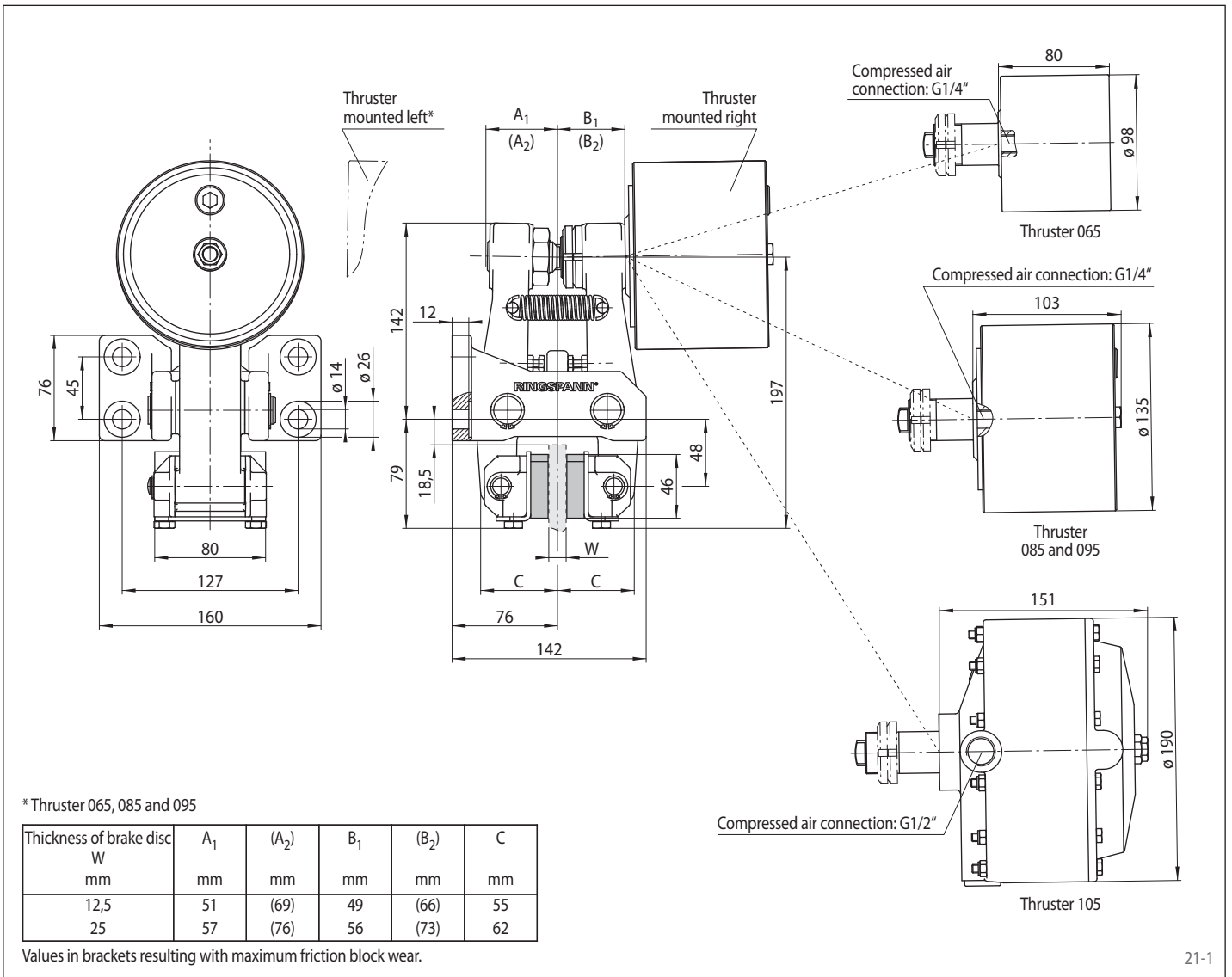

# Brake Caliper DH 030 FPA

spring activated – pneumatically released

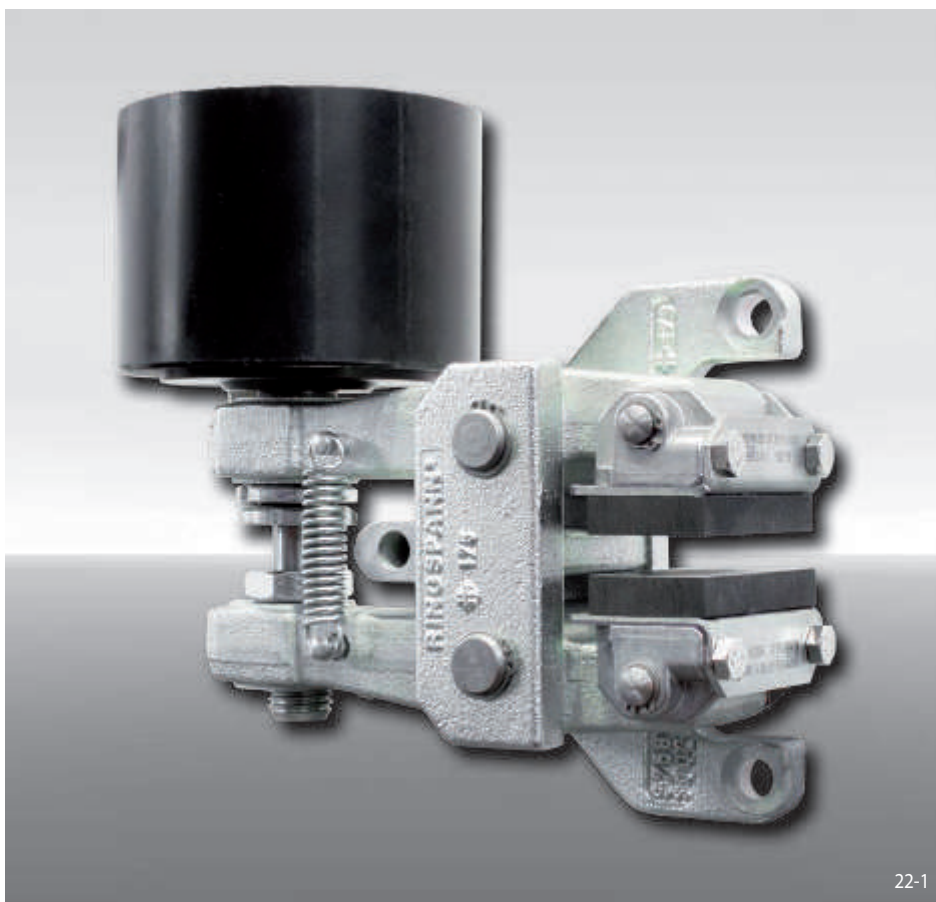

## Features

Features	Code
Brake Caliper	D
Mounting to the machine at right angles to the brake disc	H
Frame size 030	030
Spring activated	F
Pneumatically released	P
Automatic adjustment to accommodate friction block wear	A
Thrusters 065, 085, 095 or 105 are available	065 to 105
Thruster mounted right or left available	R L
Thickness of brake disc 12,5 mm or 25 mm	12 25

## Example for ordering

Brake Caliper DH 030 FPA, thruster 085, thruster mounted right, thickness of brake disc 12,5 mm:

DH 030 FPA - 085 R - 12

## Technical Data

	Brake Caliper DH 030 FPA			
	with thruster 065	with thruster 085	with thruster 095	with thruster 105
Brake disc diameter	Braking torque	Braking torque	Braking torque	Braking torque
mm	Nm	Nm	Nm	Nm
200	250	150	530	760
250	340	200	710	1050
300	430	250	900	1300
355	530	310	1100	1600
430	670	390	1400	2000
520	830	480	1700	2500
Clamping force	4500 N	2600 N	9300 N	13500 N
Air pressure	min. 5 bar max. 8 bar	min. 1,7 bar max. 8 bar	min. 5 bar max. 8 bar	min. 4,7 bar max. 8 bar
Air volume per activation	max. 72 cm <sup>3</sup>	max. 140 cm <sup>3</sup>	max. 140 cm <sup>3</sup>	max. 460 cm <sup>3</sup>
Weight	9,5 kg	11,9 kg	11,9 kg	13,5 kg

The braking torques shown in the table are based on a theoretical friction coefficient of 0,4.



# Brake Caliper DH 030 FPA

spring activated – pneumatically released

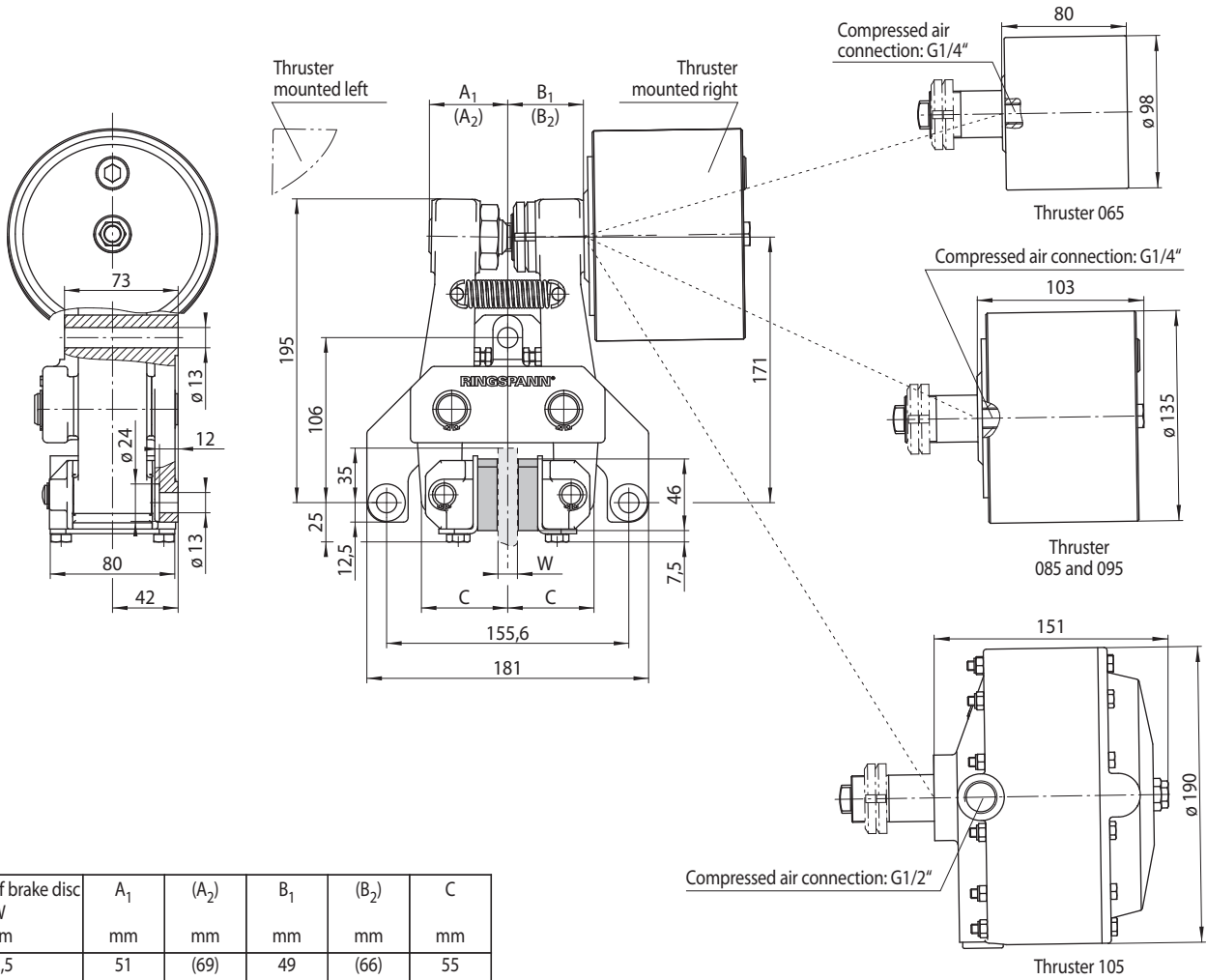

Thickness of brake disc W mm	A <sub>1</sub> mm	(A <sub>2</sub> ) mm	B <sub>1</sub> mm	(B <sub>2</sub> ) mm	C mm
12,5	51	(69)	49	(66)	55
25	57	(76)	56	(73)	62

Values in brackets resulting with maximum friction block wear.

# Brake Caliper DV 035 FPM

spring activated – pneumatically released

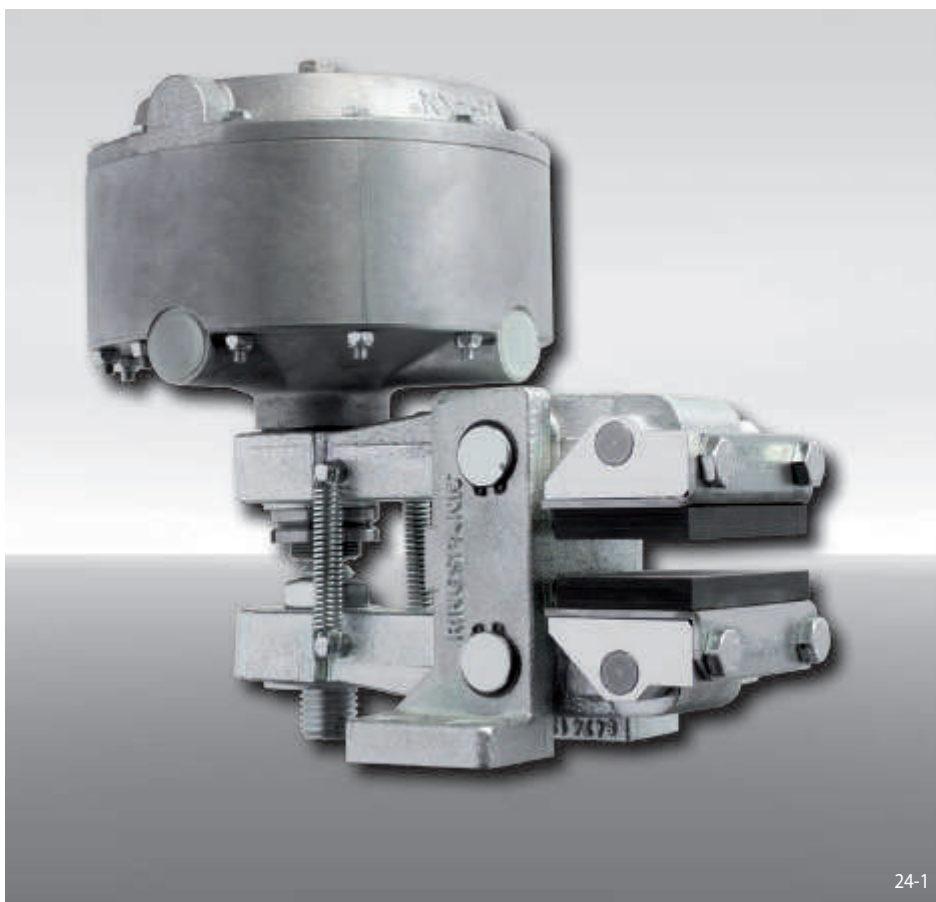

24-1

Features	Code
Brake Caliper	D
Mounting to the machine parallel to the brake disc	V
Frame size 035	035
Spring activated	F
Pneumatically released	P
Manual adjustment to accommodate friction block wear	M
Thrusters 025, 035, 045, 102, 111 or 122 are available	025 to 122
Thruster mounted right available	R
Thickness of brake disc 12,5 mm, 25 mm, 30 mm or 40 mm	12 to 40

### Example for ordering

Brake Caliper DV 035 FPM, thruster 111, thruster mounted right, thickness of brake disc 12,5 mm:

DV 035 FPM - 111 R - 12

### Technical Data

	Brake Caliper DV 035 FPM					
	with thruster 025	with thruster 035	with thruster 045	with thruster 102	with thruster 111	with thruster 122
Brake disc diameter	Braking torque	Braking torque	Braking torque	Braking torque	Braking torque	Braking torque
mm	Nm	Nm	Nm	Nm	Nm	Nm
300	430	640	900	820	1450	1850
355	530	790	1100	1000	1750	2250
430	670	990	1400	1300	2250	2850
520	840	1250	1750	1600	2800	3550
630	1050	1550	2150	2000	3450	4400
710	1200	1750	2450	2250	3950	5000
800	1350	2000	2800	2600	4500	5750
Clamping force	4600 N	6800 N	9600 N	8800 N	15300 N	19500 N
Air pressure	min. 5 bar max. 8 bar	min. 4,2 bar max. 8 bar	min. 5 bar max. 8 bar	min. 3 bar max. 8 bar	min. 5 bar max. 8 bar	min. 6,5 bar max. 8 bar
Air volume per activation	max. 120 cm <sup>3</sup>	max. 185 cm <sup>3</sup>	max. 185 cm <sup>3</sup>	max. 540 cm <sup>3</sup>	max. 540 cm <sup>3</sup>	max. 540 cm <sup>3</sup>
Weight	10,6 kg	13,0 kg	13,0 kg	14,2 kg	14,2 kg	14,2 kg

The braking torques shown in the table are based on a theoretical friction coefficient of 0,4.

# Brake Caliper DV 035 FPM

spring activated – pneumatically released

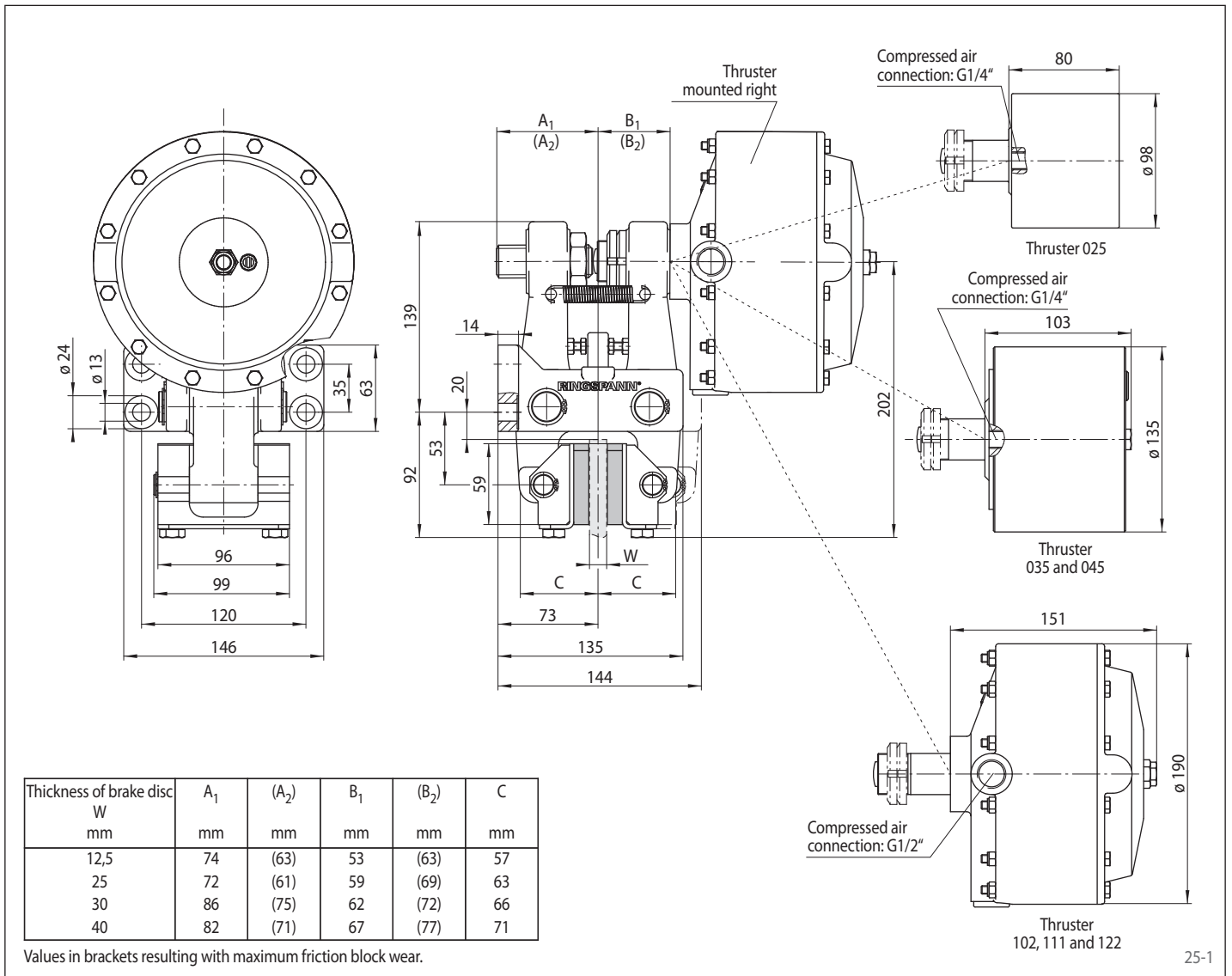

# Brake Caliper DH 035 FPM

spring activated – pneumatically released

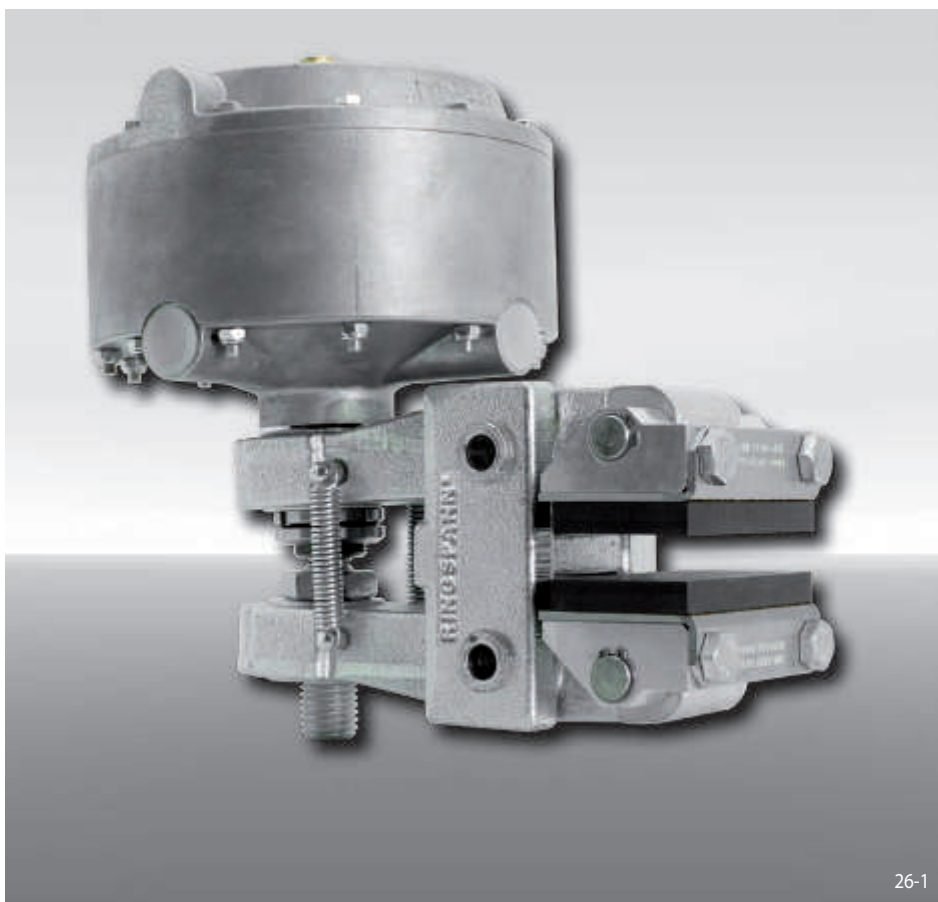

26-1

Features	Code
Brake Caliper	D
Mounting to the machine at right angles to the brake disc	H
Frame size 035	035
Spring activated	F
Pneumatically released	P
Manual adjustment to accommodate friction block wear	M
Thrusters 025, 035, 045, 102, 111 or 122 are available	025 to 122
Thruster mounted right or left available	R L
Thickness of brake disc 12,5 mm, 25 mm, 30 mm or 40 mm	12 to 40

### Example for ordering

Brake Caliper DH 035 FPM, thruster 111, thruster mounted right, thickness of brake disc 12,5 mm:

DH 035 FPM - 111 R - 12

### Technical Data

	Brake Caliper DH 035 FPM					
	with thruster 025	with thruster 035	with thruster 045	with thruster 102	with thruster 111	with thruster 122
Brake disc diameter	Braking torque	Braking torque	Braking torque	Braking torque	Braking torque	Braking torque
mm	Nm	Nm	Nm	Nm	Nm	Nm
300	430	640	900	820	1450	1850
355	530	790	1100	1000	1750	2250
430	670	990	1400	1300	2250	2850
520	840	1250	1750	1600	2800	3550
630	1050	1550	2150	2000	3450	4400
710	1200	1750	2450	2250	3950	5000
800	1350	2000	2800	2600	4500	5750
Clamping force	4600 N	6800 N	9600 N	8800 N	15300 N	19500 N
Air pressure	min. 5 bar max. 8 bar	min. 4,2 bar max. 8 bar	min. 5 bar max. 8 bar	min. 3 bar max. 8 bar	min. 5 bar max. 8 bar	min. 6,5 bar max. 8 bar
Air volume per activation	max. 120 cm <sup>3</sup>	max. 185 cm <sup>3</sup>	max. 185 cm <sup>3</sup>	max. 540 cm <sup>3</sup>	max. 540 cm <sup>3</sup>	max. 540 cm <sup>3</sup>
Weight	10,6 kg	13,0 kg	13,0 kg	14,2 kg	14,2 kg	14,2 kg

The braking torques shown in the table are based on a theoretical friction coefficient of 0,4.

# Brake Caliper DH 035 FPM

spring activated – pneumatically released

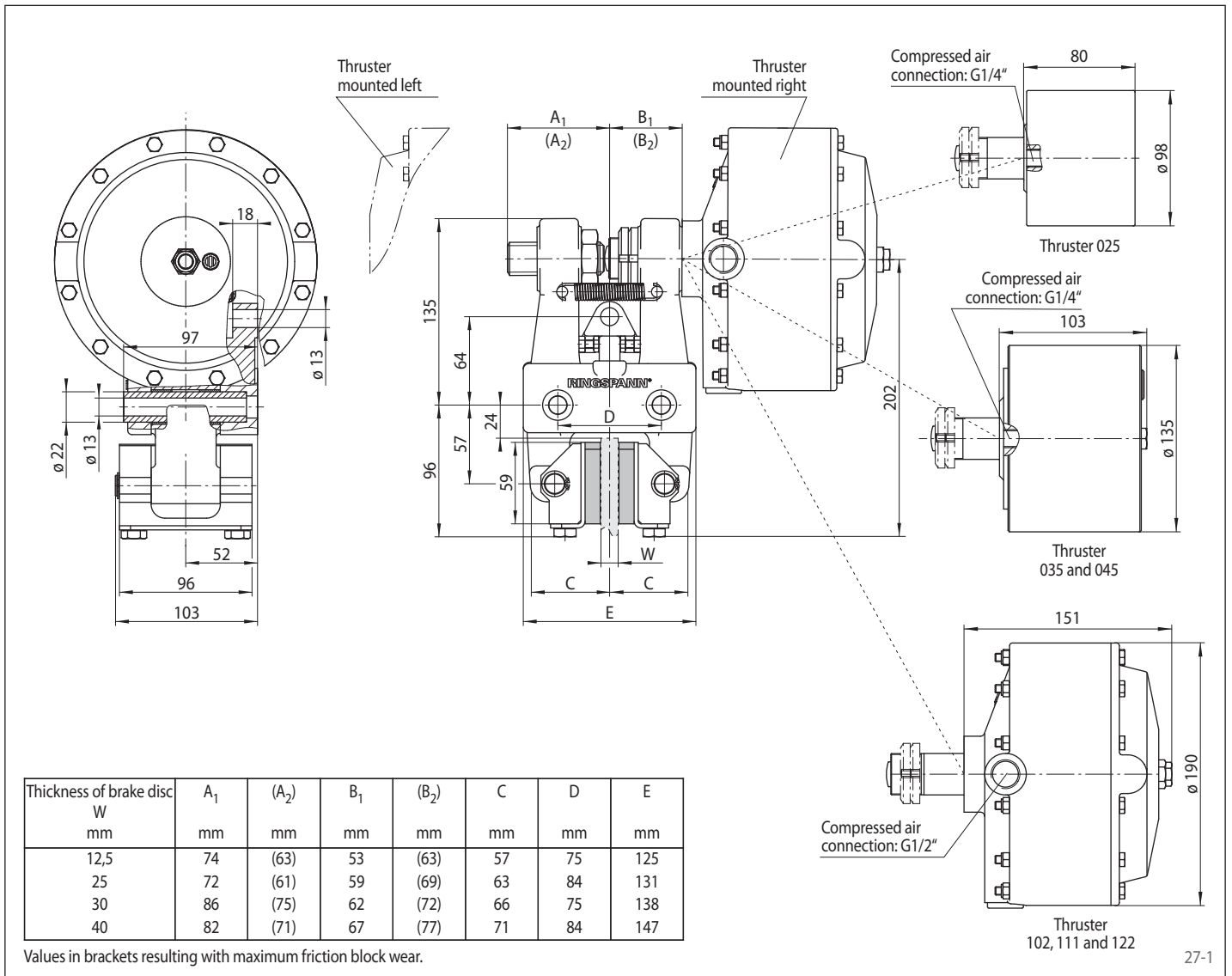

# Brake Caliper DV 035 FPA

spring activated – pneumatically released

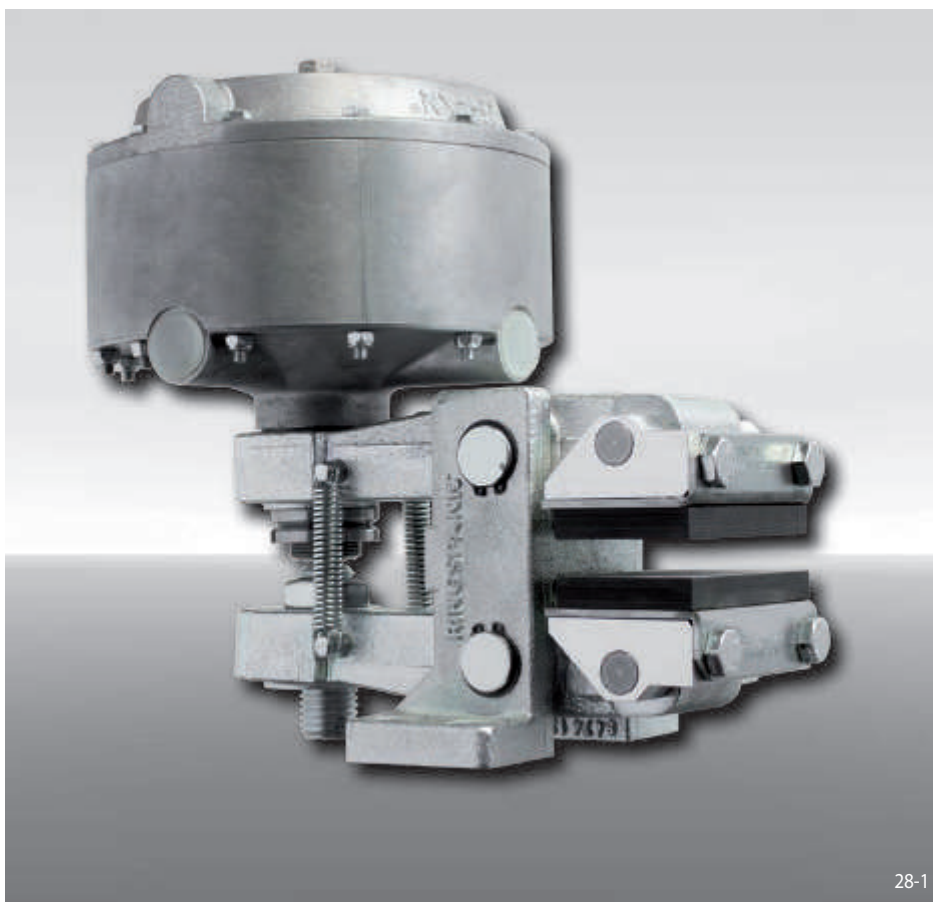

28-1

Features	Code
Brake Caliper	D
Mounting to the machine at right angles to the brake disc	V
Frame size 035	035
Spring activated	F
Pneumatically released	P
Automatic adjustment to accommodate friction block wear	A
Thrusters 065, 085, 095, 115 or 125 are available	065 to 125
Thruster mounted right available	R
Thickness of brake disc 12,5 mm, 25 mm, 30 mm or 40 mm	12 to 40

### Example for ordering

Brake Caliper DV 035 FPA, thruster 095, thruster mounted right, thickness of brake disc 12,5 mm:

DV 035 FPA - 095 R - 12

### Technical Data

	Brake Caliper DV 035 FPA				
	with thruster 065	with thruster 085	with thruster 095	with thruster 115	with thruster 125
Brake disc diameter	Braking torque	Braking torque	Braking torque	Braking torque	Braking torque
mm	Nm	Nm	Nm	Nm	Nm
300	400	230	830	1350	1750
355	500	290	1050	1700	2150
430	630	360	1300	2100	2700
520	780	450	1600	2650	3350
630	970	560	2000	3250	4150
710	1100	640	2300	3750	4750
800	1250	730	2600	4250	5450
Clamping force	4300 N	2500 N	8900 N	14500 N	18500 N
Air pressure	min. 5 bar max. 8 bar	min. 1,7 bar max. 8 bar	min. 5 bar max. 8 bar	min. 5 bar max. 8 bar	min. 6,5 bar max. 8 bar
Air volume per activation	max. 72 cm <sup>3</sup>	max. 140 cm <sup>3</sup>	max. 140 cm <sup>3</sup>	max. 460 cm <sup>3</sup>	max. 460 cm <sup>3</sup>
Weight	10,9 kg	13,3 kg	13,3 kg	14,9 kg	14,9 kg

The braking torques shown in the table are based on a theoretical friction coefficient of 0,4.



# Brake Caliper DV 035 FPA

spring activated – pneumatically released

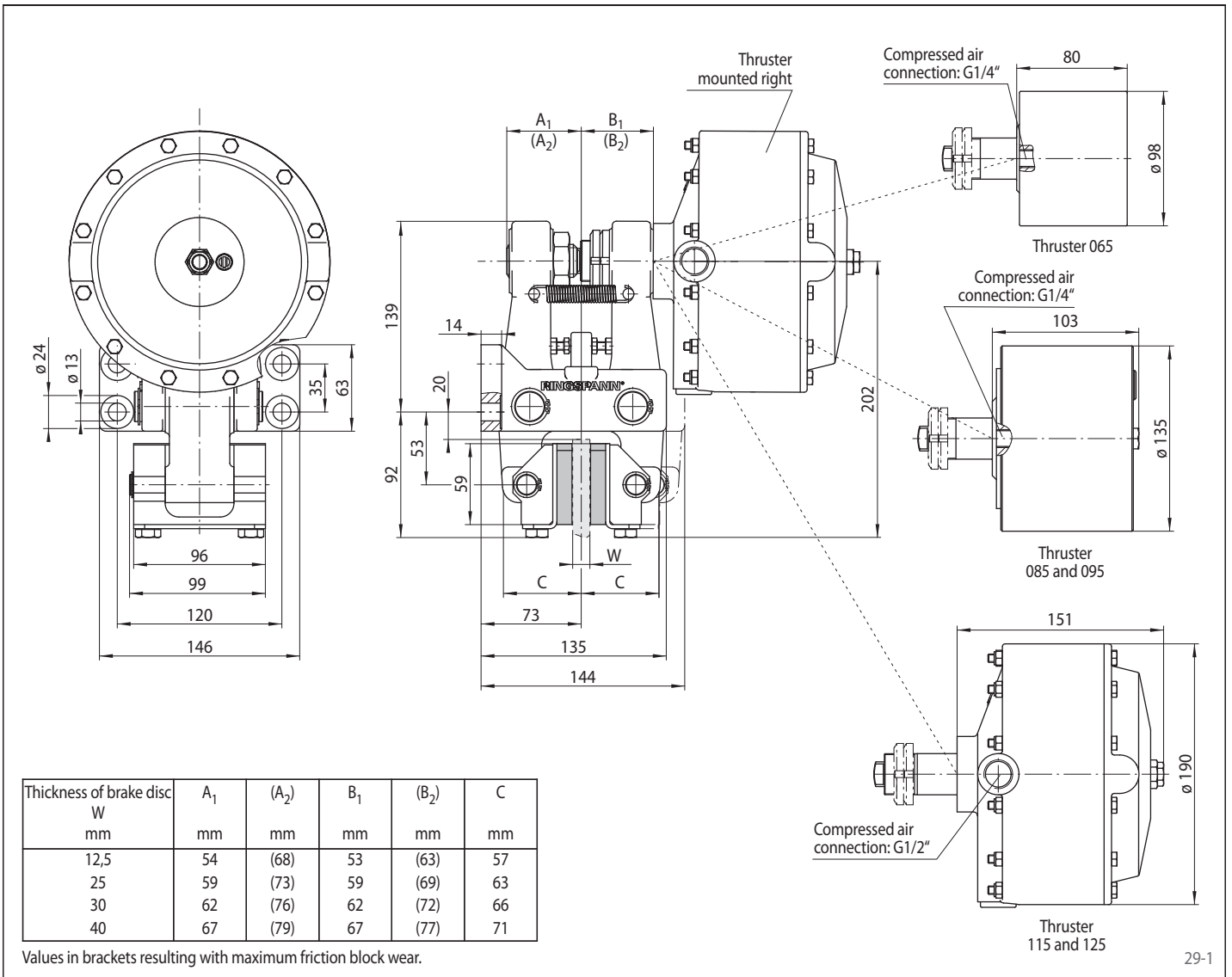

# Brake Caliper DH 035 FPA

spring activated – pneumatically released

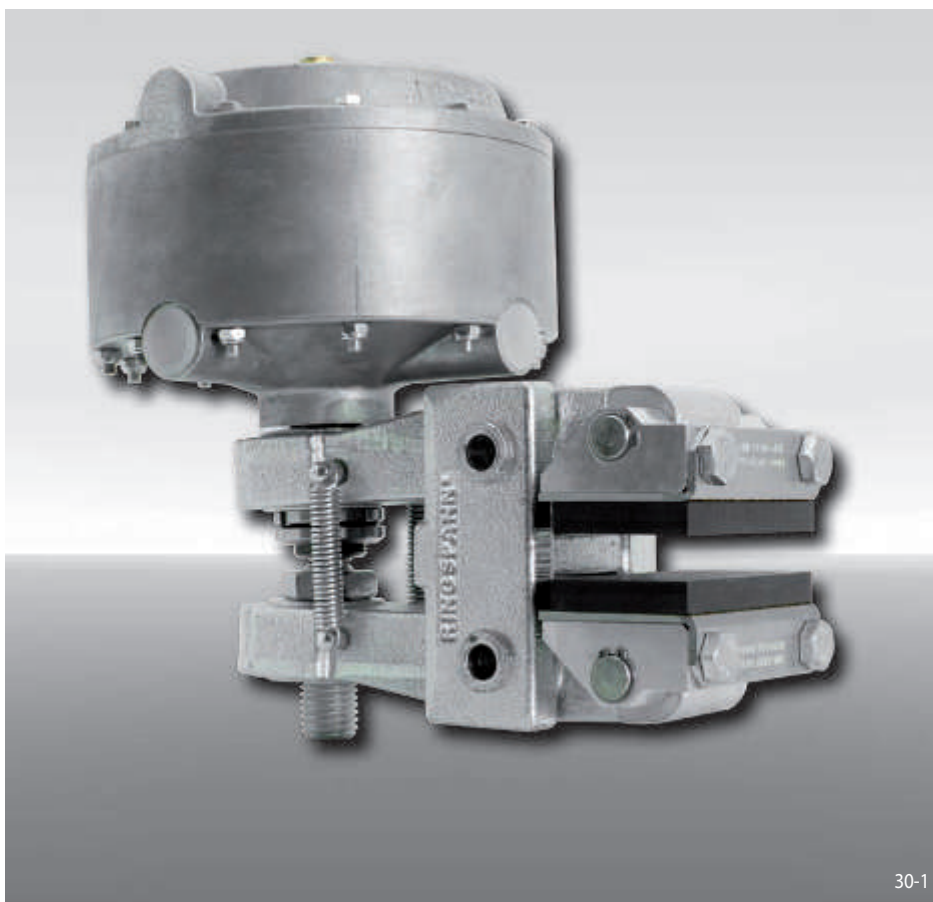

Features	Code
Brake Caliper	D
Mounting to the machine at right angles to the brake disc	H
Frame size 035	035
Spring activated	F
Pneumatically released	P
Automatic adjustment to accommodate friction block wear	A
Thrusters 065, 085, 095, 115 or 125 are available	065 to 125
Thruster mounted right or left available	R L
Thickness of brake disc 12,5 mm, 25 mm, 30 mm or 40 mm	12 to 40

### Example for ordering

Brake Caliper DH 035 FPA, thruster 095, thruster mounted right, thickness of brake disc 12,5 mm:

DH 035 FPA - 095 R - 12

### Technical Data

	Brake Caliper DH 035 FPA				
	with thruster 065	with thruster 085	with thruster 095	with thruster 115	with thruster 125
Brake disc diameter	Braking torque	Braking torque	Braking torque	Braking torque	Braking torque
mm	Nm	Nm	Nm	Nm	Nm
300	400	230	830	1350	1750
355	500	290	1050	1700	2150
430	630	360	1300	2100	2700
520	780	450	1600	2650	3350
630	970	560	2000	3250	4150
710	1100	640	2300	3750	4750
800	1250	730	2600	4250	5450
Clamping force	4300 N	2500 N	8900 N	14500 N	18500 N
Air pressure	min. 5 bar max. 8 bar	min. 1,7 bar max. 8 bar	min. 5 bar max. 8 bar	min. 5 bar max. 8 bar	min. 6,5 bar max. 8 bar
Air volume per activation	max. 72 cm <sup>3</sup>	max. 140 cm <sup>3</sup>	max. 140 cm <sup>3</sup>	max. 460 cm <sup>3</sup>	max. 460 cm <sup>3</sup>
Weight	10,9 kg	13,3 kg	13,3 kg	14,9 kg	14,9 kg

The braking torques shown in the table are based on a theoretical friction coefficient of 0,4.

# Brake Caliper DH 035 FPA

spring activated – pneumatically released

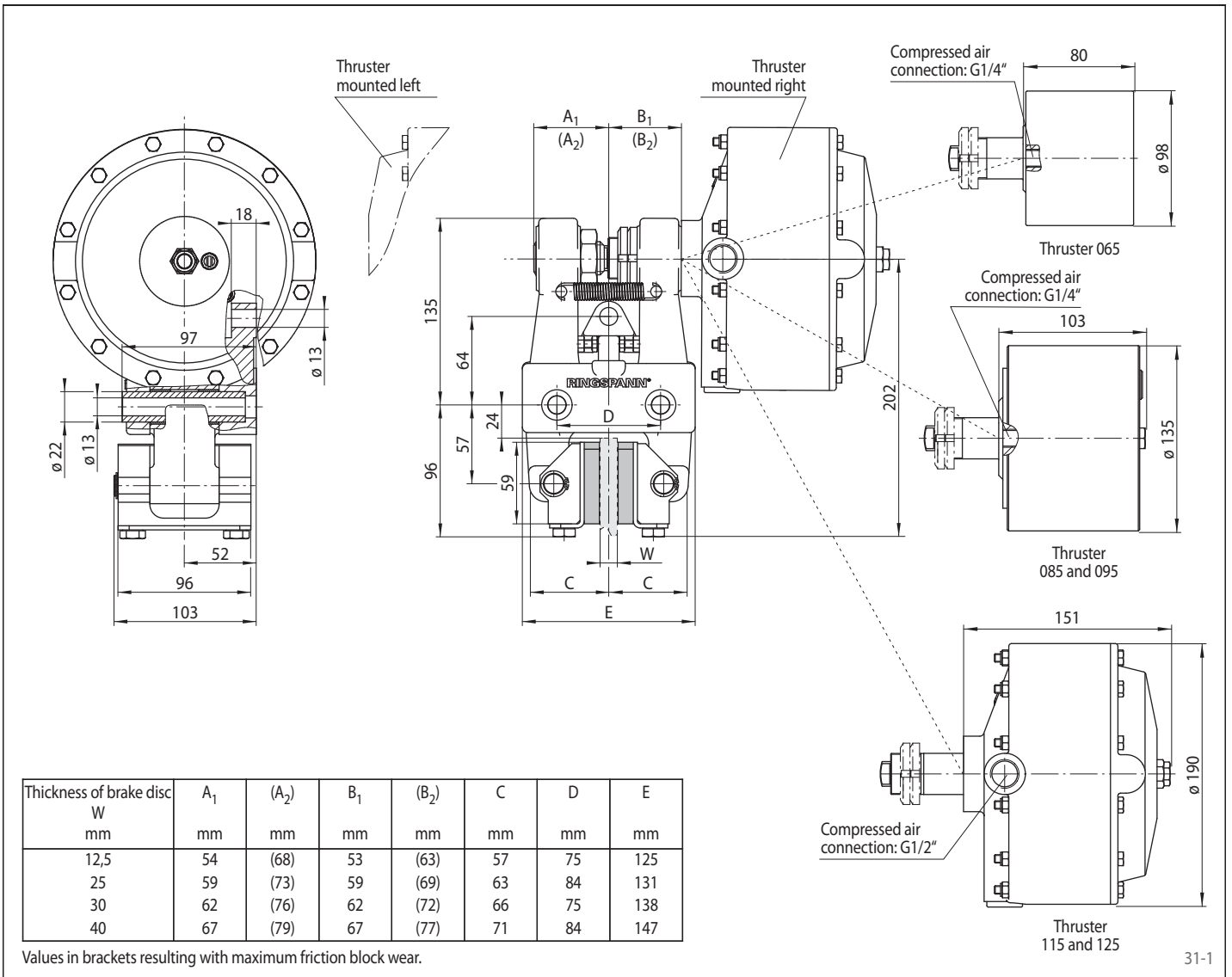

# Brake Caliper DU 060 FPM

spring activated – pneumatically released

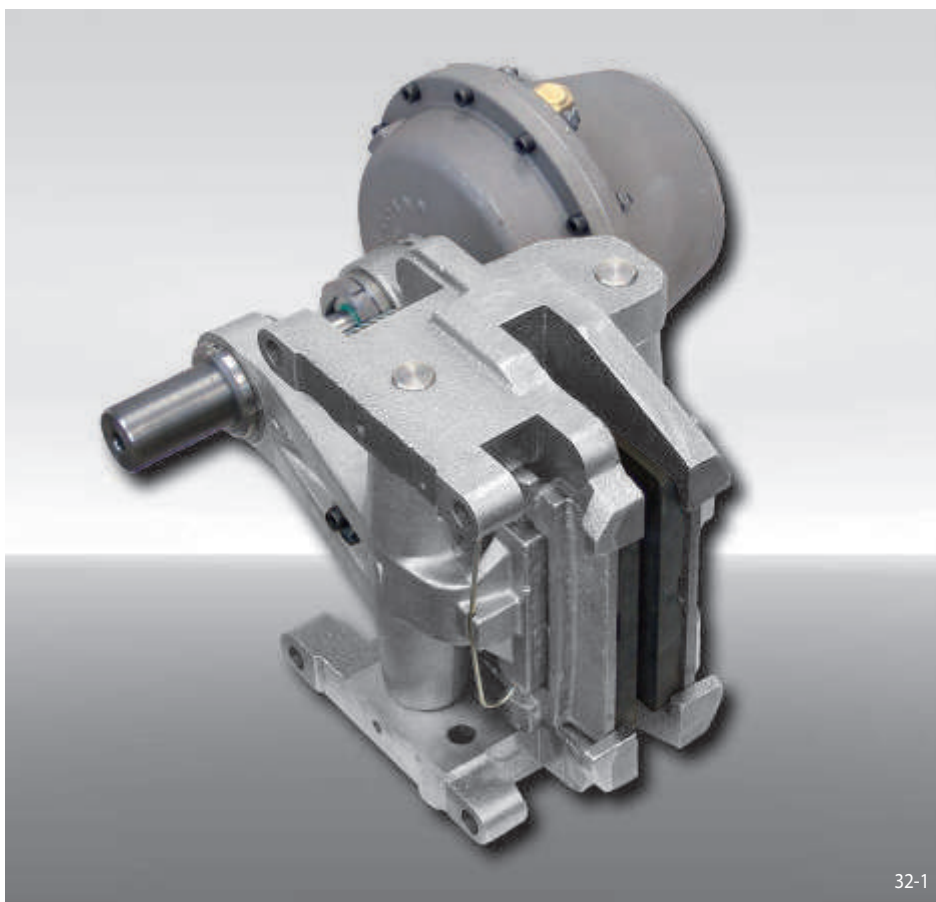

Features	Code
Brake Caliper	D
Mounting to the machine, can be made either parallel or at the right angles to the brake disc	U
Frame size 060	060
Spring activated	F
Pneumatically released	P
Manual adjustment to accommodate friction block wear	M
Thrusters 111, 122, 130, 135, 140, 150, 155 or 160 are available	111 to 160
Thruster mounted right or left available	R L
Thickness of brake disc 25 mm or 40 mm	25 40

### Example for ordering

Brake Caliper DU 060 FPM, thruster 130, thruster mounted right, thickness of brake disc 25 mm:

DU 060 FPM - 130 R - 25

### Technical Data

	Brake Caliper DU 060 FPM							
	with thruster 111	with thruster 122	with thruster 130	with thruster 135	with thruster 140	with thruster 150	with thruster 155	with thruster 160
Brake disc diameter	Braking torque	Braking torque	Braking torque	Braking torque	Braking torque	Braking torque	Braking torque	Braking torque
mm	Nm	Nm	Nm	Nm	Nm	Nm	Nm	Nm
630	4900	6300	2700	5400	7800	7300	10300	13000
710	5600	7300	3100	6200	9000	8500	12000	15500
800	6500	8400	3600	7200	10300	9700	14000	17500
900	7400	9700	4100	8300	11900	11200	16000	20500
1000	8400	10900	4700	9300	13500	12500	18000	23000
1250	10700	14000	6000	12000	17000	16000	23000	29500
1600	14000	18500	7800	16000	22500	21000	30000	38500
Clamping force	24000 N	31000 N	13200 N	26500 N	38000 N	36000 N	51000 N	65000 N
Air pressure	min. 5 bar max. 8 bar	min. 6,5 bar max. 8 bar	min. 2,8 bar max. 8,5 bar	min. 5,5 bar max. 8,5 bar	min. 8,5 bar max. 10 bar	min. 4,5 bar max. 8,5 bar	min. 5,5 bar max. 8,5 bar	min. 7,6 bar max. 8,5 bar
Air volume per activation	max. 80 cm <sup>3</sup>	max. 80 cm <sup>3</sup>	max. 200 cm <sup>3</sup>	max. 200 cm <sup>3</sup>	max. 200 cm <sup>3</sup>	max. 400 cm <sup>3</sup>	max. 400 cm <sup>3</sup>	max. 400 cm <sup>3</sup>
Weight	60 kg	60 kg	62 kg	62 kg	62 kg	70 kg	70 kg	70 kg

The braking torques shown in the table are based on a theoretical friction coefficient of 0,4.

# Brake Caliper DU 060 FPM

spring activated – pneumatically released

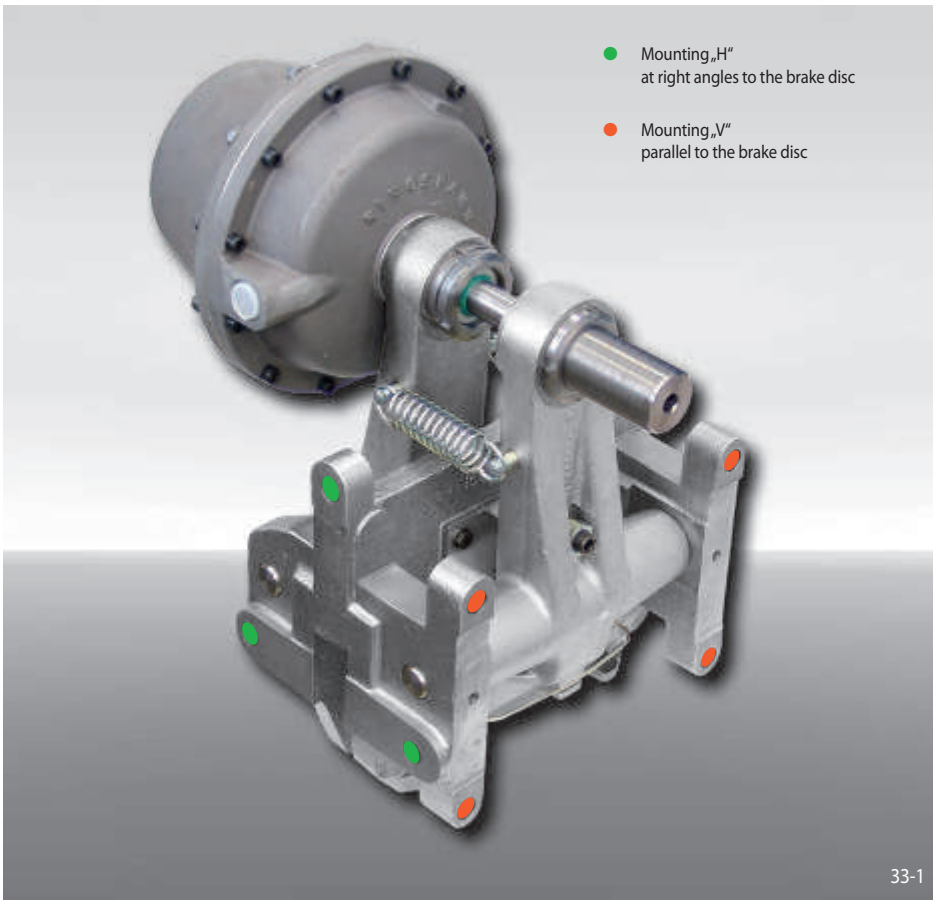

- Mounting „H“ at right angles to the brake disc
- Mounting „V“ parallel to the brake disc

33-1

## Frame Design

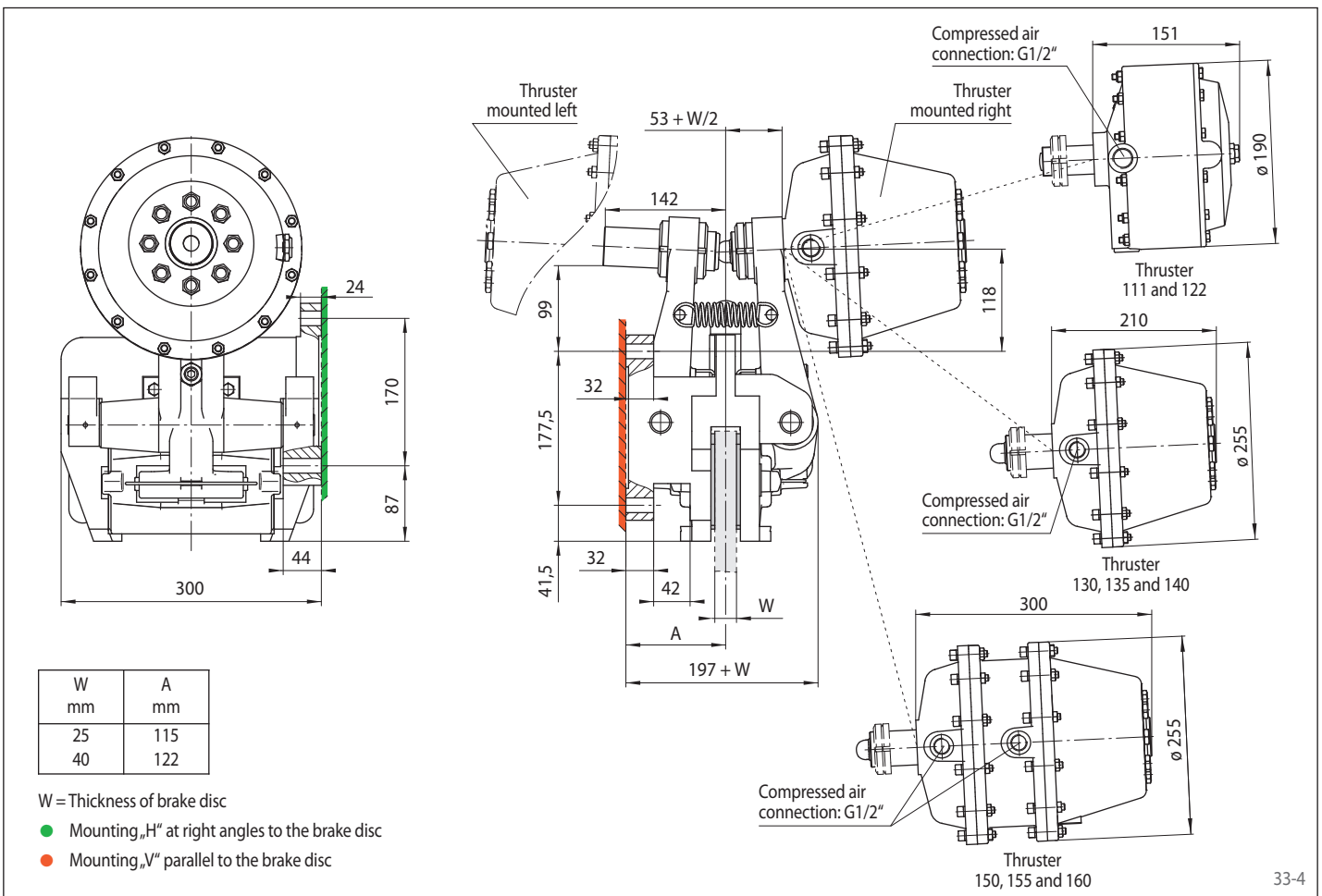
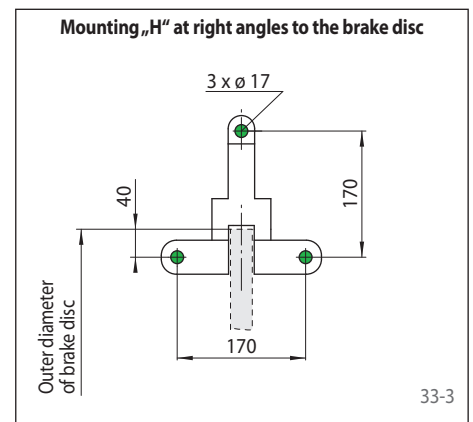
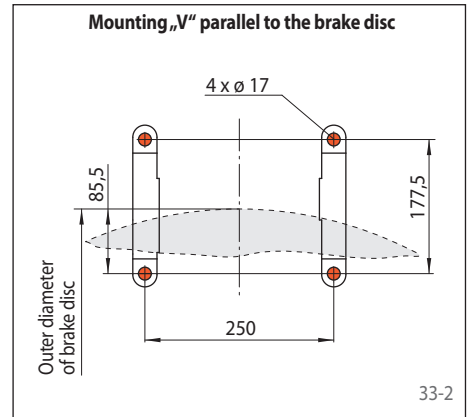

# Brake Caliper DV 020 FHM

spring activated – hydraulically released

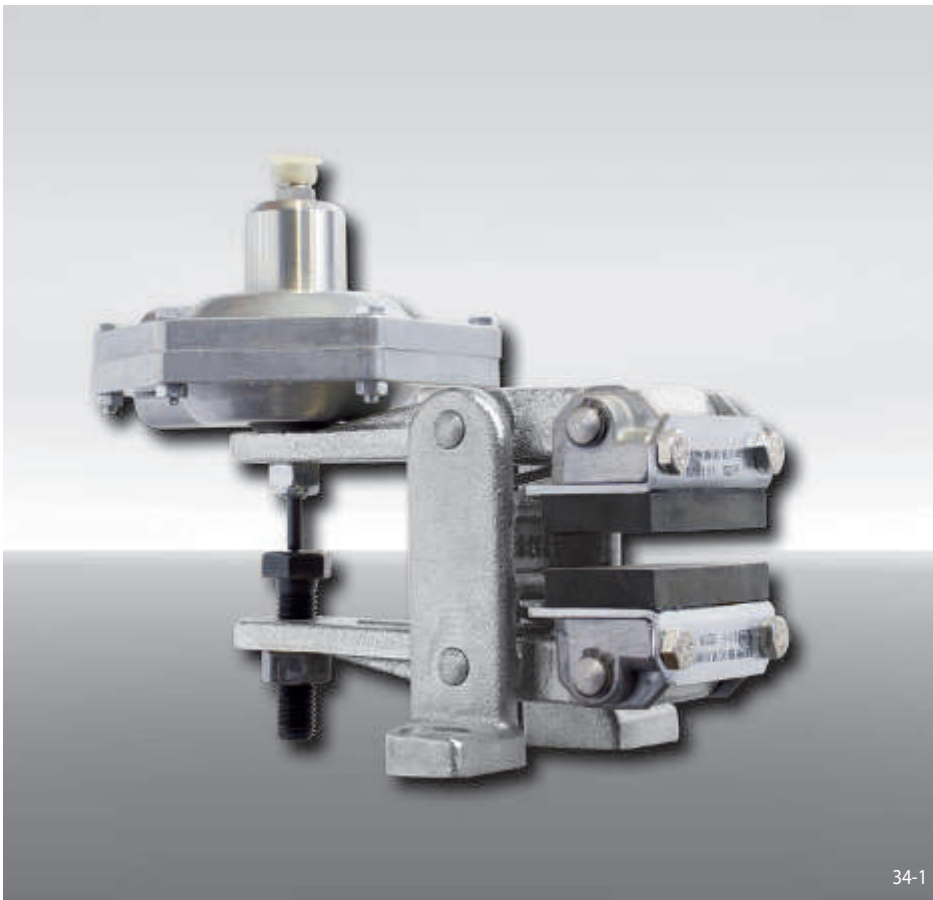

34-1

## Features

Features	Code
Brake Caliper	D
Mounting to the machine parallel to the brake disc	V
Frame size 020	020
Spring activated	F
Hydraulically released	H
Manual adjustment to accommodate friction block wear	M
Thruster 210	210
Thruster mounted right or left available	R L
Thickness of brake disc 12,5 mm	12

## Example for ordering

Brake Caliper DV 020 FHM, thruster 210, thruster mounted right, thickness of brake disc 12,5 mm:

DV 020 FHM - 210 R - 12

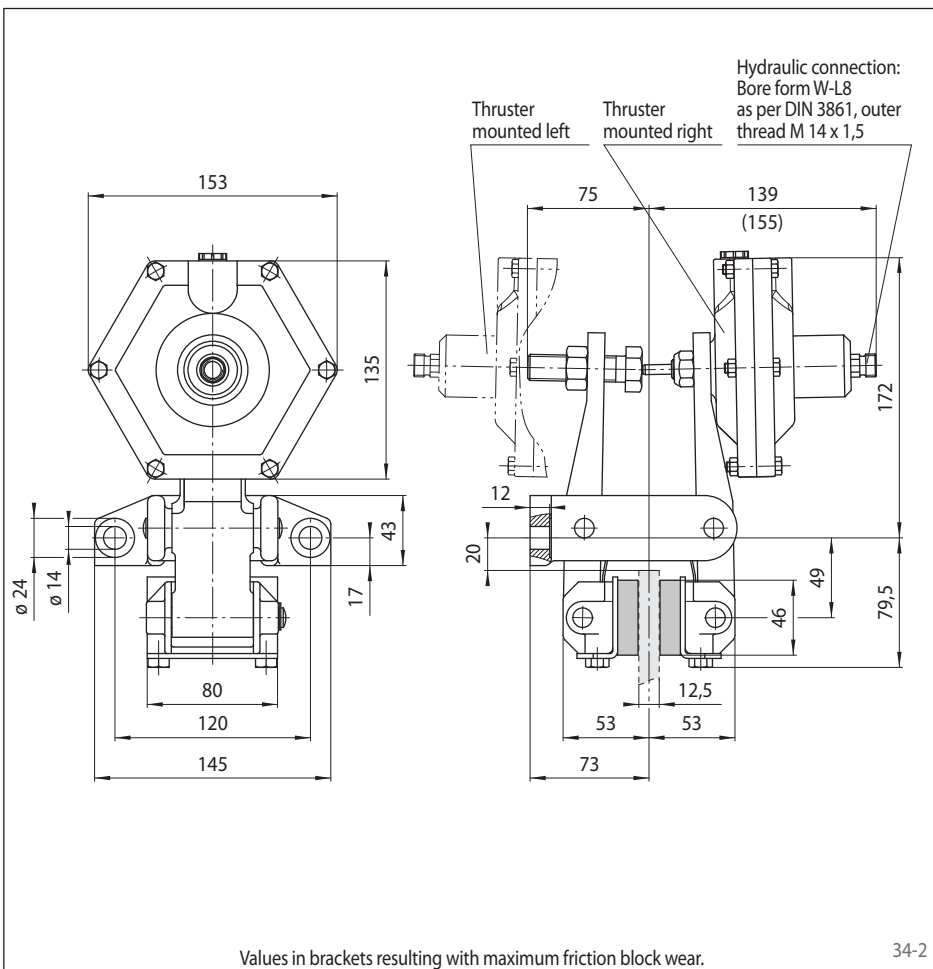

34-2

## Technical Data

Brake Caliper DV 020 FHM with thruster 210	
Brake disc diameter	Braking torque
mm	Nm
200	200
250	270
300	340
355	420
430	520
520	650
Clamping force	3500 N
Oil pressure	min. 65 bar max. 100 bar
Oil volume	max. 2,5 cm <sup>3</sup>
Weight	5,4 kg

The braking torques shown in the table are based on a theoretical friction coefficient of 0,4.



# Brake Caliper DH 020 FHM

spring activated – hydraulically released

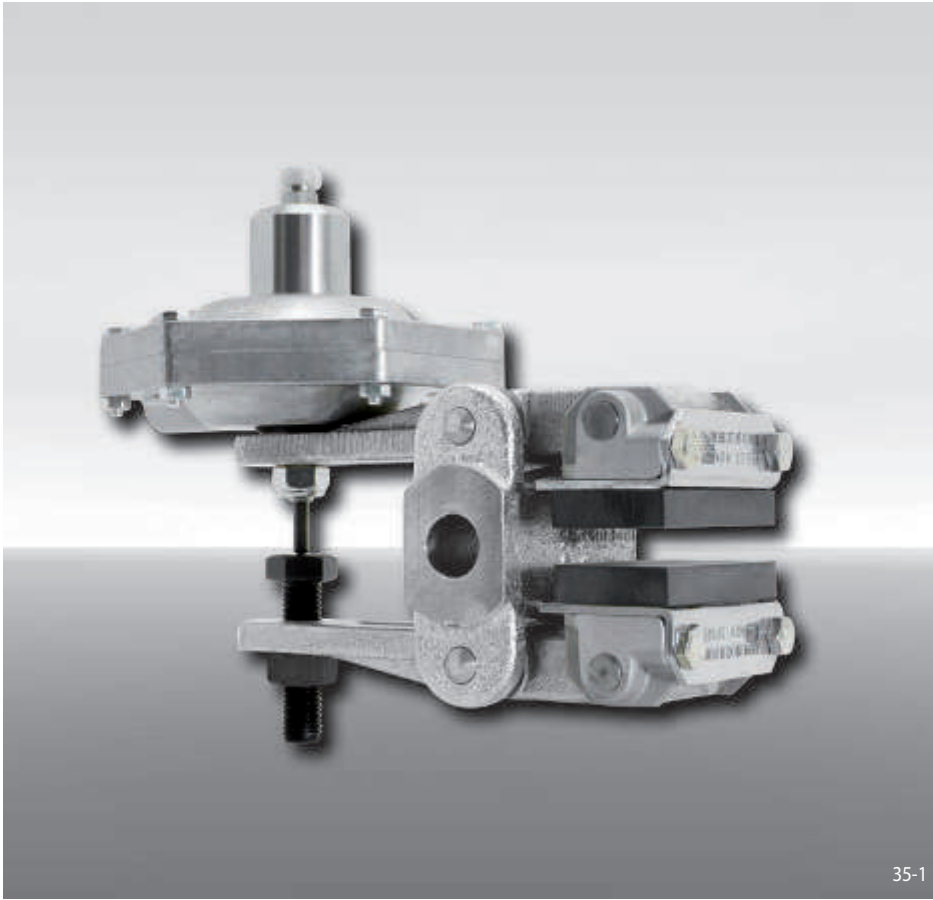

35-1

## Features

Features	Code
Brake Caliper	D
Mounting to the machine at right angles to the brake disc	H
Frame size 020	020
Spring activated	F
Hydraulically released	H
Manual adjustment to accommodate friction block wear	M
Thruster 210	210
Position of the thruster to the right or left can be defined by turning the brake around during installation	U
Thickness of brake disc 12,5 mm	12

## Example for ordering

Brake Caliper DH 020 FHM, thruster 210, position of the thruster can be to the right or left, thickness of brake disc 12,5 mm:

DH 020 FHM - 210 U - 12

## Technical Data

Brake Caliper DH 020 FHM with thruster 210	
Brake disc diameter	Braking torque
mm	Nm
200	200
250	270
300	340
355	420
430	520
520	650
Clamping force	3500 N
Oil pressure	min. 65 bar max. 100 bar
Oil volume	max. 2,5 cm <sup>3</sup>
Weight	5,4 kg

The braking torques shown in the table are based on a theoretical friction coefficient of 0,4.

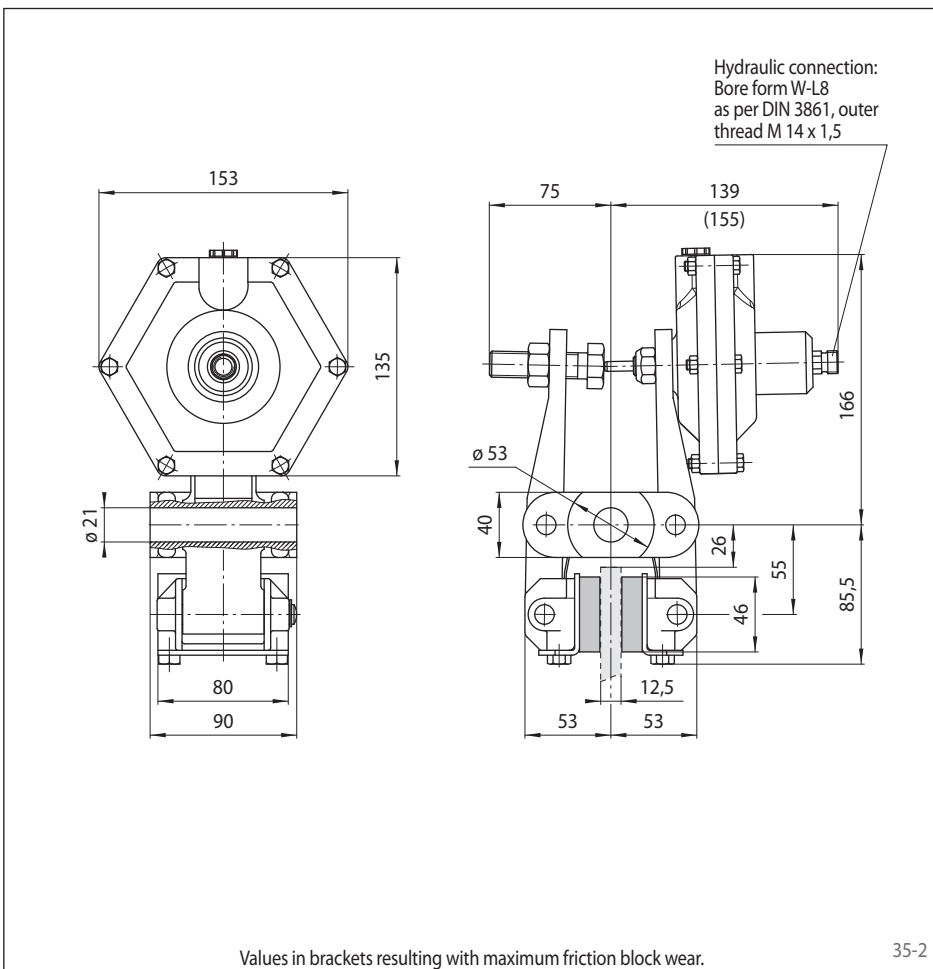

Values in brackets resulting with maximum friction block wear.

35-2

# Brake Caliper DV 030 FHM

spring activated – hydraulically released

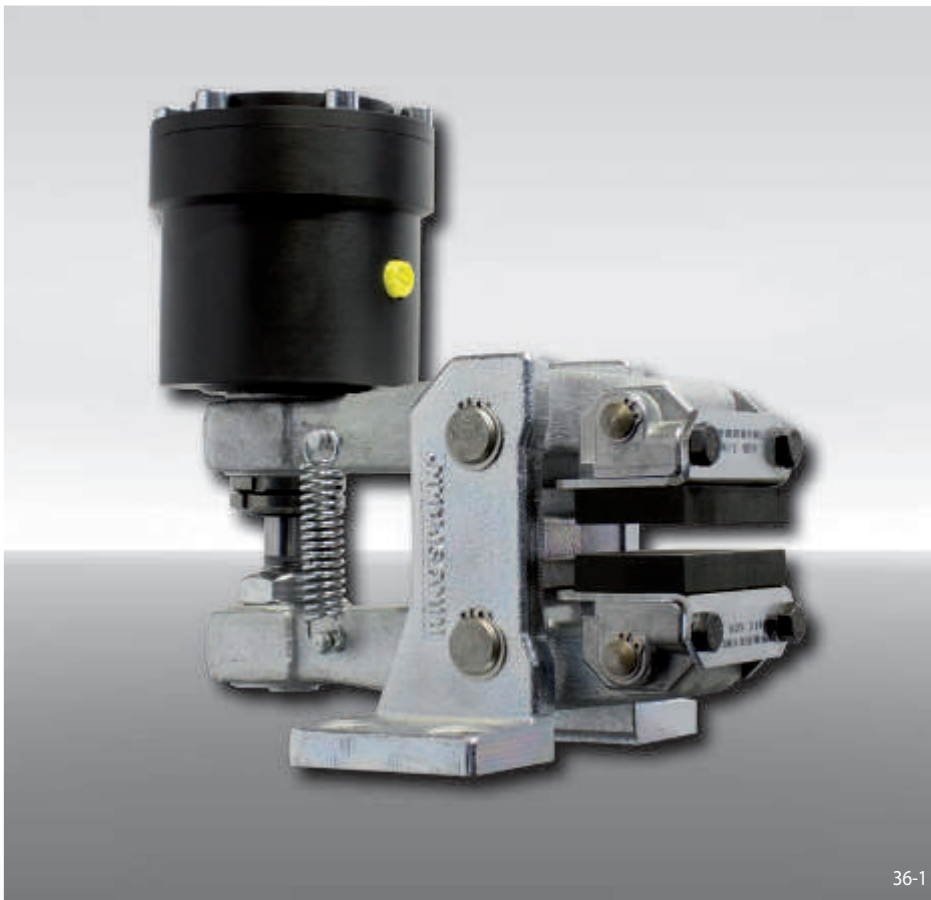

36-1

## Features

Features	Code
Brake Caliper	D
Mounting to the machine parallel to the brake disc	V
Frame size 030	030
Spring activated	F
Hydraulically released	H
Manual adjustment to accommodate friction block wear	M
Thruster 250	250
Thruster mounted right or left available	R L
Thickness of brake disc 12,5 mm or 25 mm	12 25

## Example for ordering

Brake Caliper DV 030 FHM, thruster 250, thruster mounted right, thickness of brake disc 12,5 mm:

DV 030 FHM - 250 R - 12

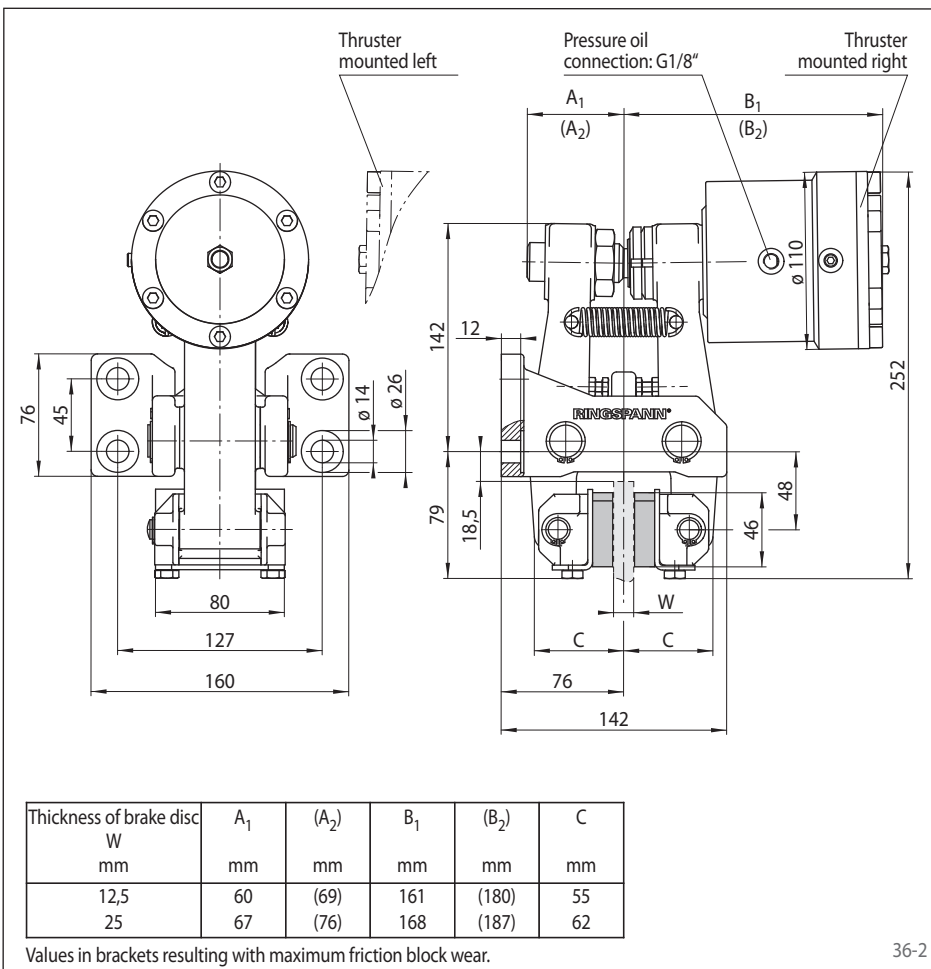

36-2

## Technical Data

Brake Caliper DV 030 FHM with thruster 250	
Brake disc diameter mm	Braking torque Nm
200	620
250	840
300	1100
355	1300
430	1600
520	2000
Clamping force	11000 N
Oil pressure	min. 40 bar max. 120 bar
Oil volume	max. 6 cm <sup>3</sup>
Weight	14,5 kg

The braking torques shown in the table are based on a theoretical friction coefficient of 0,4.

# Brake Caliper DH 030 FHM

spring activated – hydraulically released

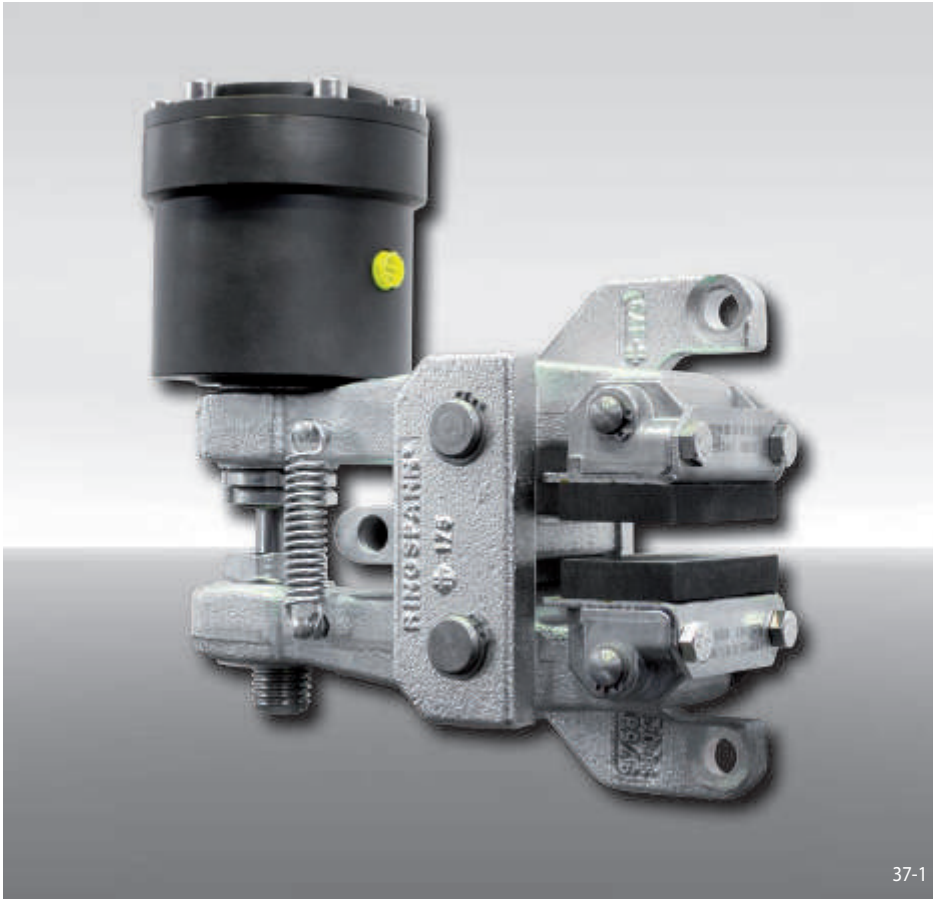

## Features

Features	Code
Brake Caliper	D
Mounting to the machine at right angles to the brake disc	H
Frame size 030	030
Spring activated	F
Hydraulically released	H
Manual adjustment to accommodate friction block wear	M
Thruster 250	250
Thruster mounted right or left available	R L
Thickness of brake disc 12,5 mm or 25 mm	12 25

## Example for ordering

Brake Caliper DH 030 FHM, thruster 250, thruster mounted right, thickness of brake disc 12,5 mm:

DH 030 FHM - 250 R - 12

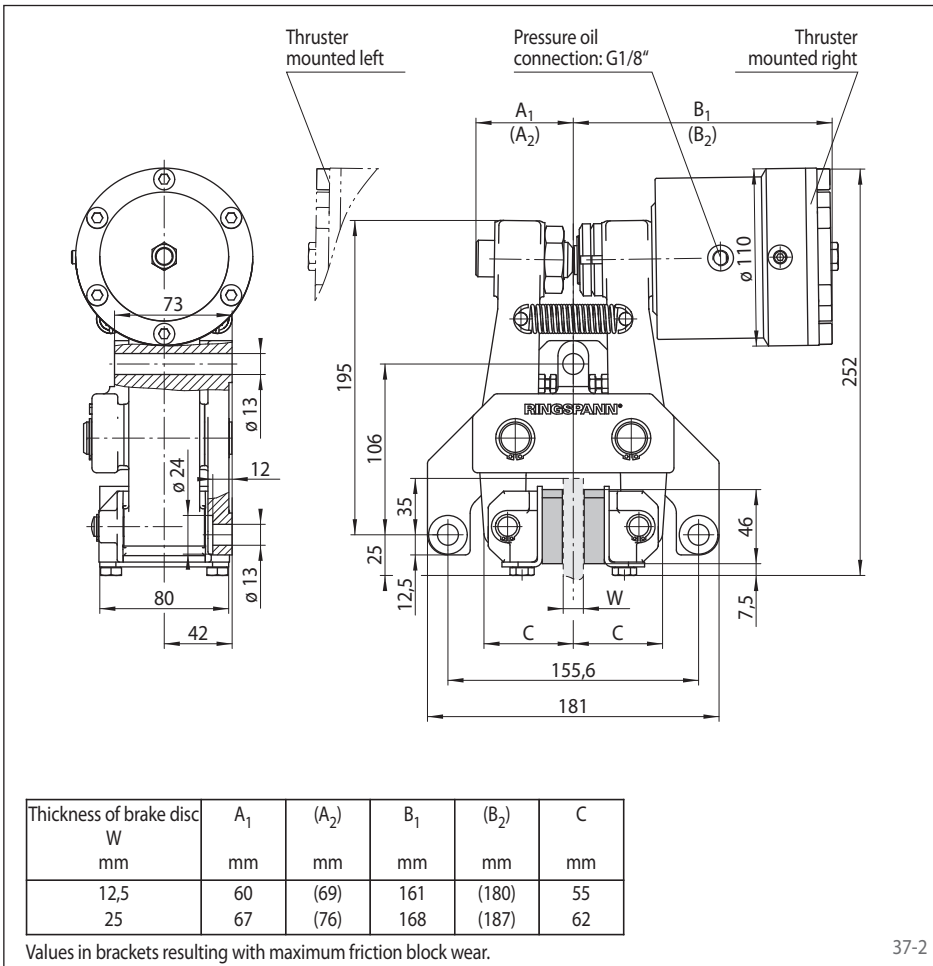

## Technical Data

Brake Caliper DH 030 FHM with thruster 250	
Brake disc diameter mm	Braking torque Nm
200	620
250	840
300	1100
355	1300
430	1600
520	2000
Clamping force	11000 N
Oil pressure	min. 40 bar max. 120 bar
Oil volume	max. 6 cm <sup>3</sup>
Weight	14,5 kg

The braking torques shown in the table are based on a theoretical friction coefficient of 0,4.

37-1

37-2

# Brake Caliper DV 030 FHA

spring activated – hydraulically released

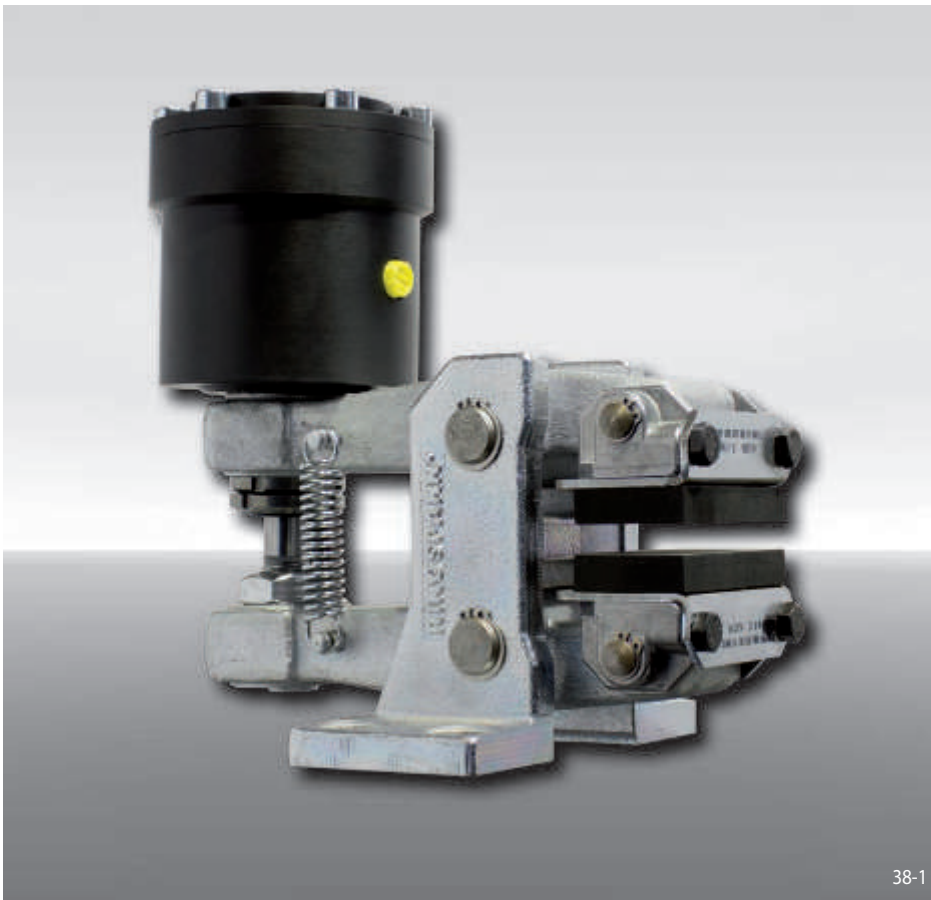

## Features

Features	Code
Brake Caliper	D
Mounting to the machine parallel to the brake disc	V
Frame size 030	030
Spring activated	F
Hydraulically released	H
Automatic adjustment to accommodate friction block wear	A
Thruster 240	240
Thruster mounted right or left available	R L
Thickness of brake disc 12,5 mm or 25 mm	12 25

## Example for ordering

Brake Caliper DV 030 FHA, thruster 240, thruster mounted right, thickness of brake disc 12,5 mm:

DV 030 FHA - 240 R - 12

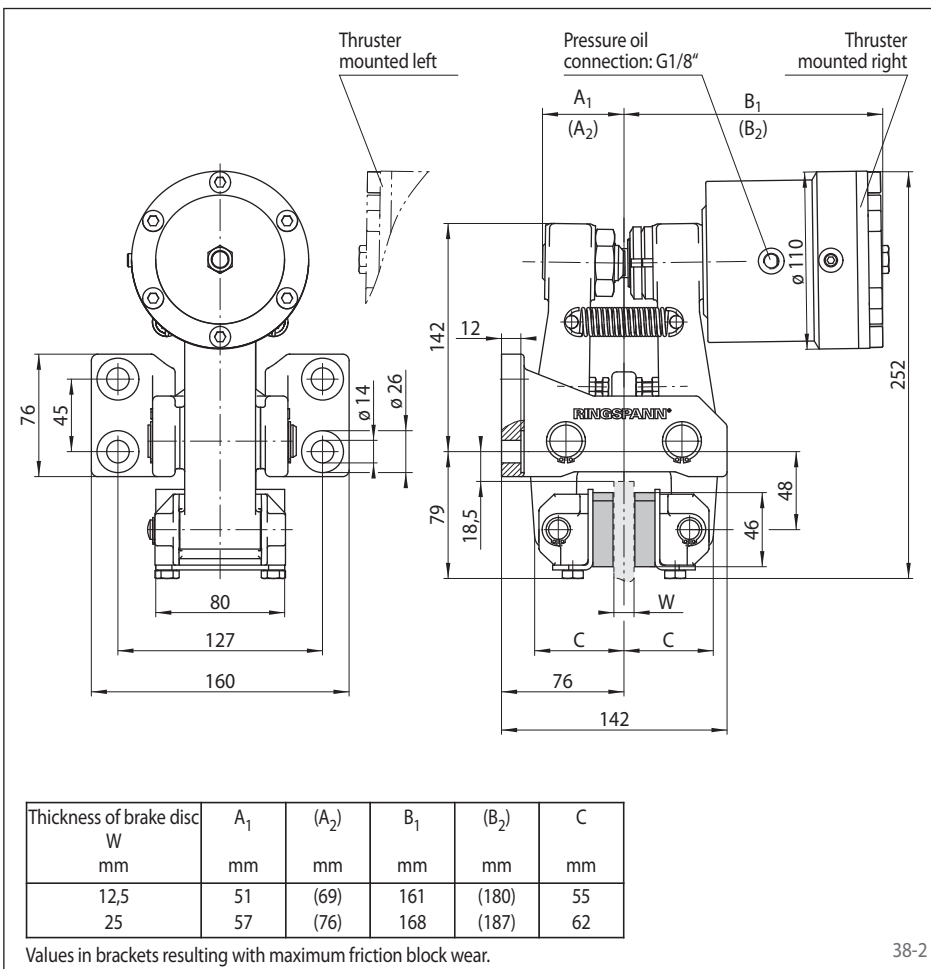

## Technical Data

Brake Caliper DV 030 FHA with thruster 240	
Brake disc diameter mm	Braking torque Nm
200	620
250	840
300	1100
355	1300
430	1600
520	2000
Clamping force	11000 N
Oil pressure	min. 40 bar max. 120 bar
Oil volume	max. 6 cm <sup>3</sup>
Weight	14,2 kg

The braking torques shown in the table are based on a theoretical friction coefficient of 0,4.





# Brake Caliper DV 035 FHM

spring activated – hydraulically released



## Features

Features	Code
Brake Caliper	D
Mounting to the machine parallel to the brake disc	V
Frame size 035	035
Spring activated	F
Hydraulically released	H
Manual adjustment to accommodate friction block wear	M
Thruster 270	270
Thruster mounted right or left available	R L
Thickness of brake disc 12,5 mm or 25 mm	12 25

## Example for ordering

Brake Caliper DV 035 FHM, thruster 270, thruster mounted right, thickness of brake disc 12,5 mm:

DV 035 FHM - 270 R - 12

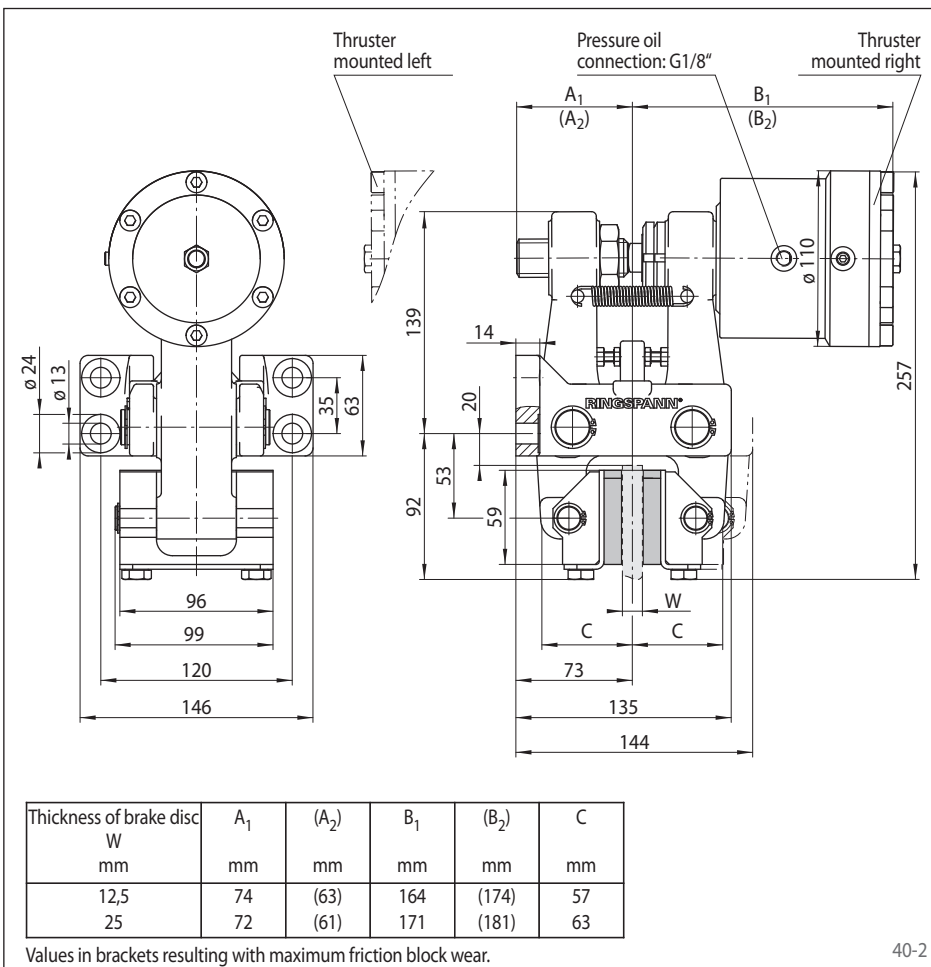

## Technical Data

Brake Caliper DV 035 FHM with thruster 270	
Brake disc diameter mm	Braking torque Nm
300	1500
355	1850
430	2350
520	3000
630	3600
710	4100
800	4700
Clamping force	16000 N
Oil pressure	min. 55 bar max. 120 bar
Oil volume	max. 6 cm <sup>3</sup>
Weight	13,7 kg

The braking torques shown in the table are based on a theoretical friction coefficient of 0,4.

# Brake Caliper DH 035 FHM

spring activated – hydraulically released

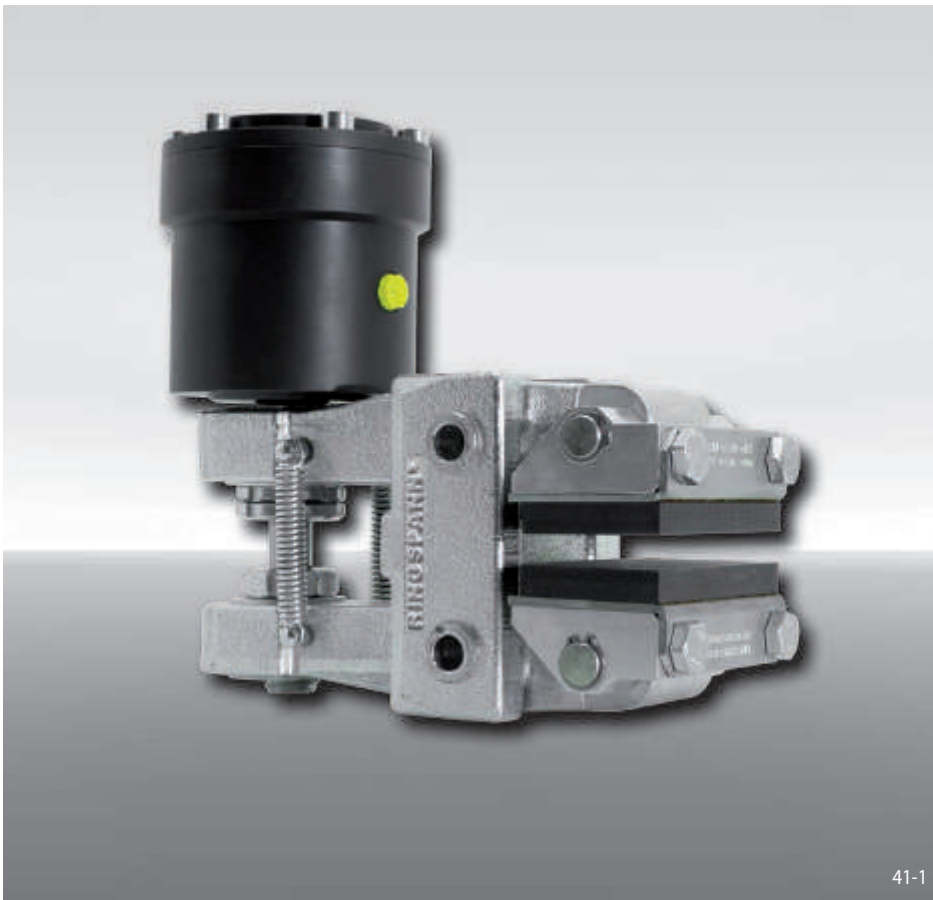

41-1

## Features

Features	Code
Brake Caliper	D
Mounting to the machine at right angles to the brake disc	H
Frame size 035	035
Spring activated	F
Hydraulically released	H
Manual adjustment to accommodate friction block wear	M
Thruster 270	270
Thruster mounted right or left available	R L
Thickness of brake disc 12,5 mm or 25 mm	12 25

## Example for ordering

Brake Caliper DH 035 FHM, thruster 270, thruster mounted right, thickness of brake disc 12,5 mm:

DH 035 FHM - 270 R - 12

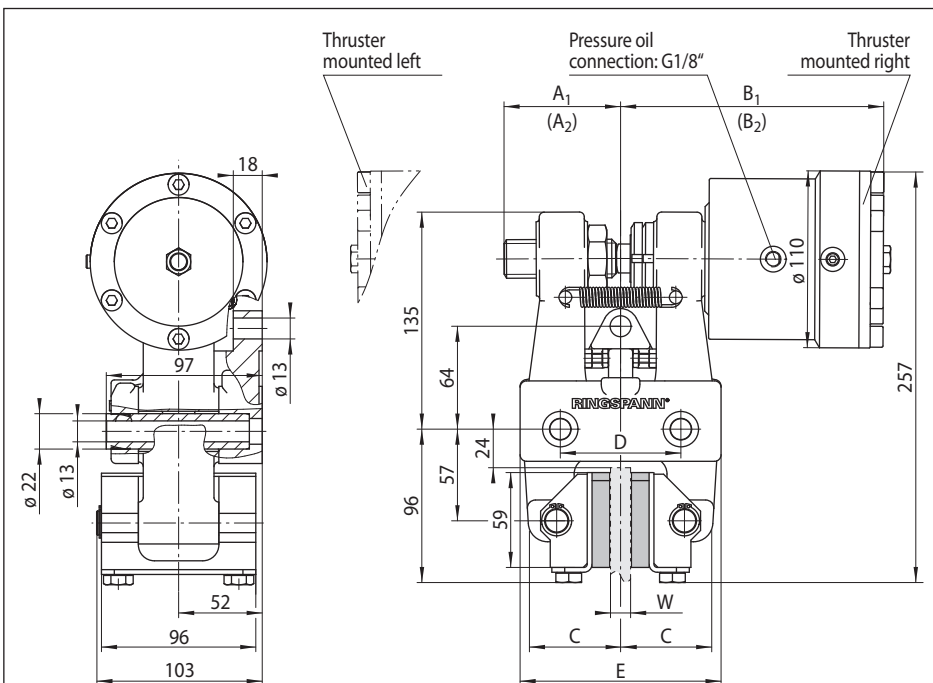

## Technical Data

Brake Caliper DH 035 FHM with thruster 270	
Brake disc diameter	Braking torque
mm	Nm
300	1500
355	1850
430	2350
520	3000
630	3600
710	4100
800	4700
Clamping force	16000 N
Oil pressure	min. 55 bar max. 120 bar
Oil volume	max. 6 cm <sup>3</sup>
Weight	13,9 kg

The braking torques shown in the table are based on a theoretical friction coefficient of 0,4.

Thickness of brake disc W mm	A <sub>1</sub> mm	(A <sub>2</sub> ) mm	B <sub>1</sub> mm	(B <sub>2</sub> ) mm	C mm	D mm	E mm
12,5	74	(63)	164	(174)	57	75	125
25	72	(61)	171	(181)	63	84	131

Values in brackets resulting with maximum friction block wear.

41-2



# Brake Caliper DV 035 FHA

spring activated – hydraulically released



42-1

## Features

Features	Code
Brake Caliper	D
Mounting to the machine parallel to the brake disc	V
Frame size 035	035
Spring activated	F
Hydraulically released	H
Automatic adjustment to accommodate friction block wear	A
Thruster 260	260
Thruster mounted right or left available	R L
Thickness of brake disc 12,5 mm or 25 mm	12 25

## Example for ordering

Brake Caliper DV 035 FHA, thruster 260, thruster mounted right, thickness of brake disc 12,5 mm:

DV 035 FHA - 260 R - 12

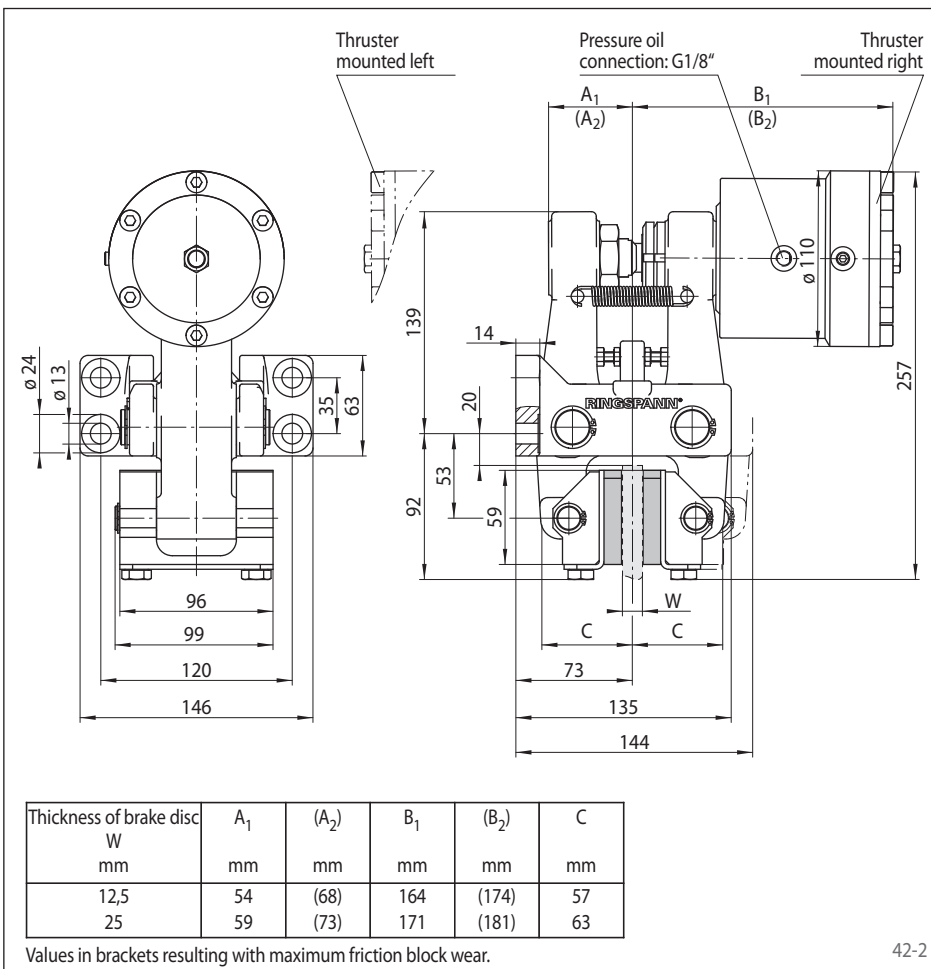

42-2

## Technical Data

Brake Caliper DV 035 FHA with thruster 260	
Brake disc diameter mm	Braking torque Nm
300	1500
355	1850
430	2350
520	3000
630	3600
710	4100
800	4700
Clamping force	16000 N
Oil pressure	min. 55 bar max. 120 bar
Oil volume	max. 6 cm <sup>3</sup>
Weight	13,9 kg

The braking torques shown in the table are based on a theoretical friction coefficient of 0,4.

# Brake Caliper DH 035 FHA

spring activated – hydraulically released



## Features

Features	Code
Brake Caliper	D
Mounting to the machine at right angles to the brake disc	H
Frame size 035	035
Spring activated	F
Hydraulically released	H
Automatic adjustment to accommodate friction block wear	A
Thruster 260	260
Thruster mounted right or left available	R L
Thickness of brake disc 12,5 mm or 25 mm	12 25

## Example for ordering

Brake Caliper DH 035 FHA, thruster 260, thruster mounted right, thickness of brake disc 12,5 mm:

DH 035 FHA - 260 R - 12

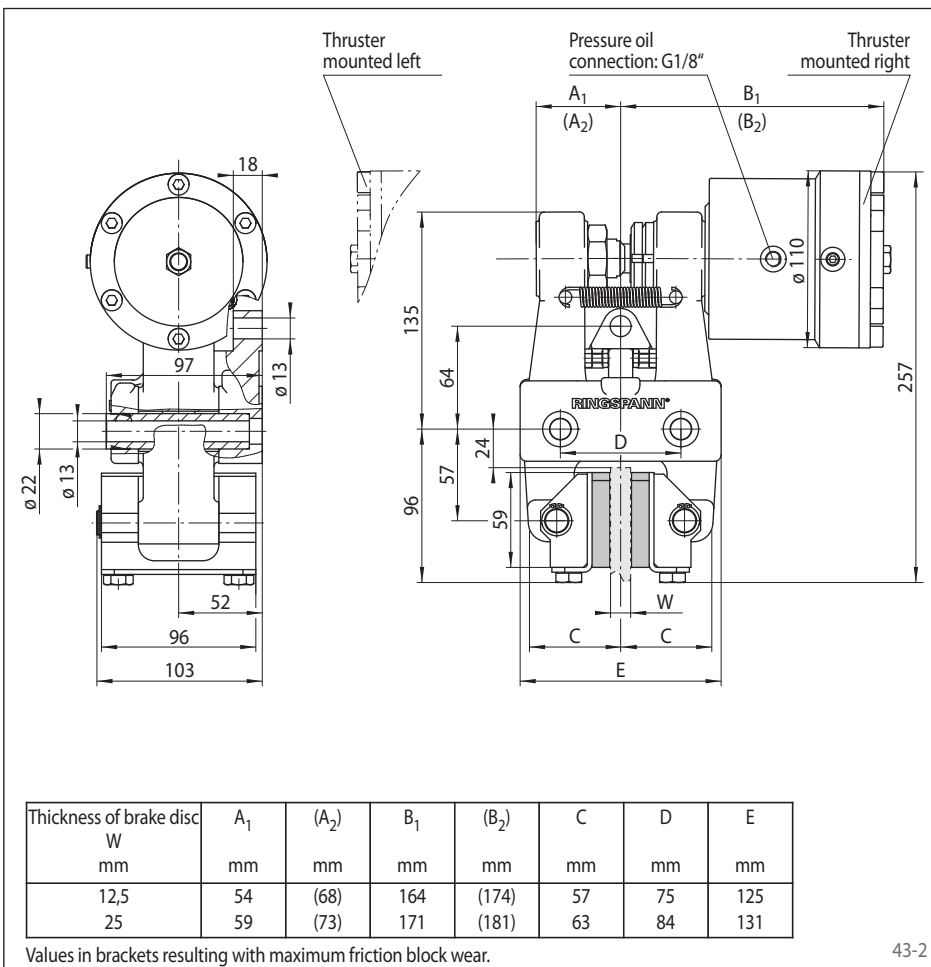

## Technical Data

Brake Caliper DH 035 FHA with thruster 260	
Brake disc diameter mm	Braking torque Nm
300	1500
355	1850
430	2350
520	3000
630	3600
710	4100
800	4700
Clamping force	16000 N
Oil pressure	min. 55 bar max. 120 bar
Oil volume	max. 6 cm <sup>3</sup>
Weight	14,1 kg

The braking torques shown in the table are based on a theoretical friction coefficient of 0,4.

# Brake Caliper DU 060 FHM

spring activated – hydraulically released

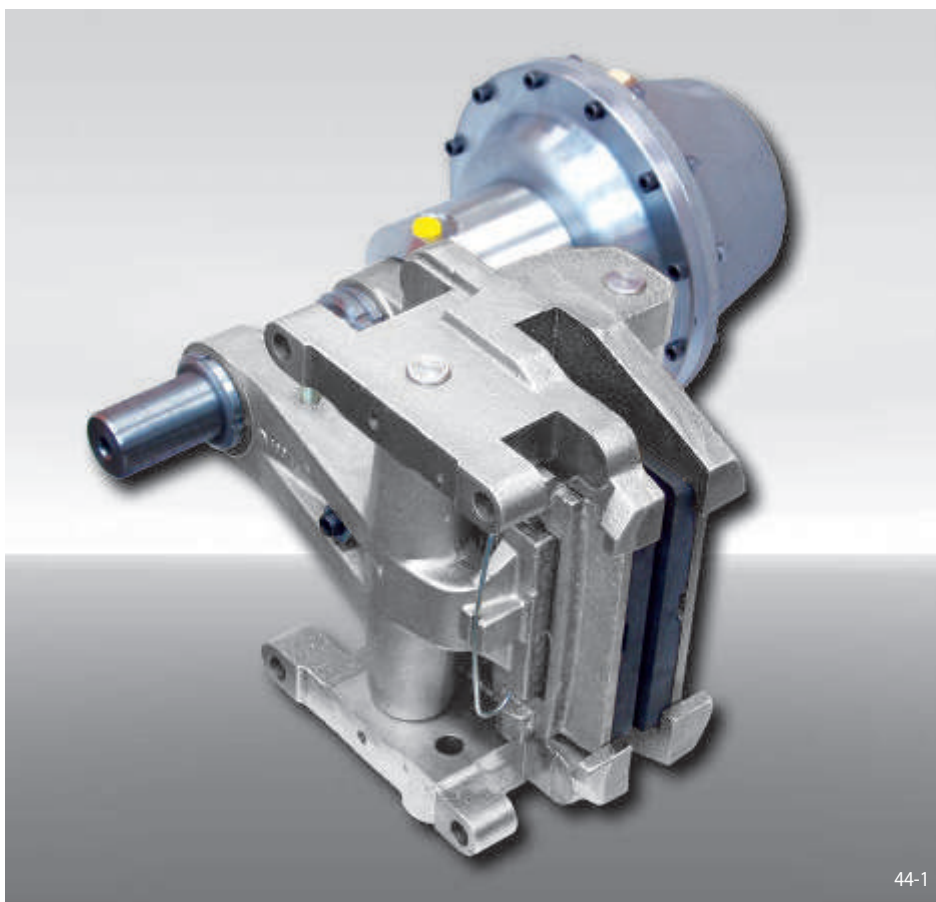

44-1

Features	Code
Brake Caliper	D
Mounting to the machine, can be made either parallel or at the right angles to the brake disc	U
Frame size 060	060
Spring activated	F
Hydraulically released	H
Manual adjustment to accommodate friction block wear	M
Thrusters 340, 350, 360 or 370 are available	340 to 370
Thruster mounted right or left available	R L
Thickness of brake disc 25 mm or 40 mm	25 40

### Example for ordering

Brake Caliper DU 060 FHM, thruster 340, thruster mounted right, thickness of brake disc 25 mm:

DU 060 FHM - 340 R - 25

### Technical Data

	Brake Caliper DU 060 FHM			
	with thruster 340	with thruster 350	with thruster 360	with thruster 370
Brake disc diameter	Braking torque	Braking torque	Braking torque	Braking torque
mm	Nm	Nm	Nm	Nm
630	2700	5400	7800	13500
710	3100	6200	9000	15500
800	3600	7200	10300	17500
900	4100	8300	11900	20500
1000	4700	9300	13400	23000
1250	6000	12000	17000	29500
1600	7800	15500	22500	38500
Clamping force	13200 N	26500 N	38000 N	65000 N
Oil pressure	min. 20 bar max. 125 bar	min. 30 bar max. 125 bar	min. 50 bar max. 125 bar	min. 80 bar max. 125 bar
Oil volume	max. 158 cm <sup>3</sup>	max. 158 cm <sup>3</sup>	max. 158 cm <sup>3</sup>	max. 158 cm <sup>3</sup>
Weight	71 kg	71 kg	71 kg	71 kg

The braking torques shown in the table are based on a theoretical friction coefficient of 0,4.

# Brake Caliper DU 060 FHM

spring activated – hydraulically released

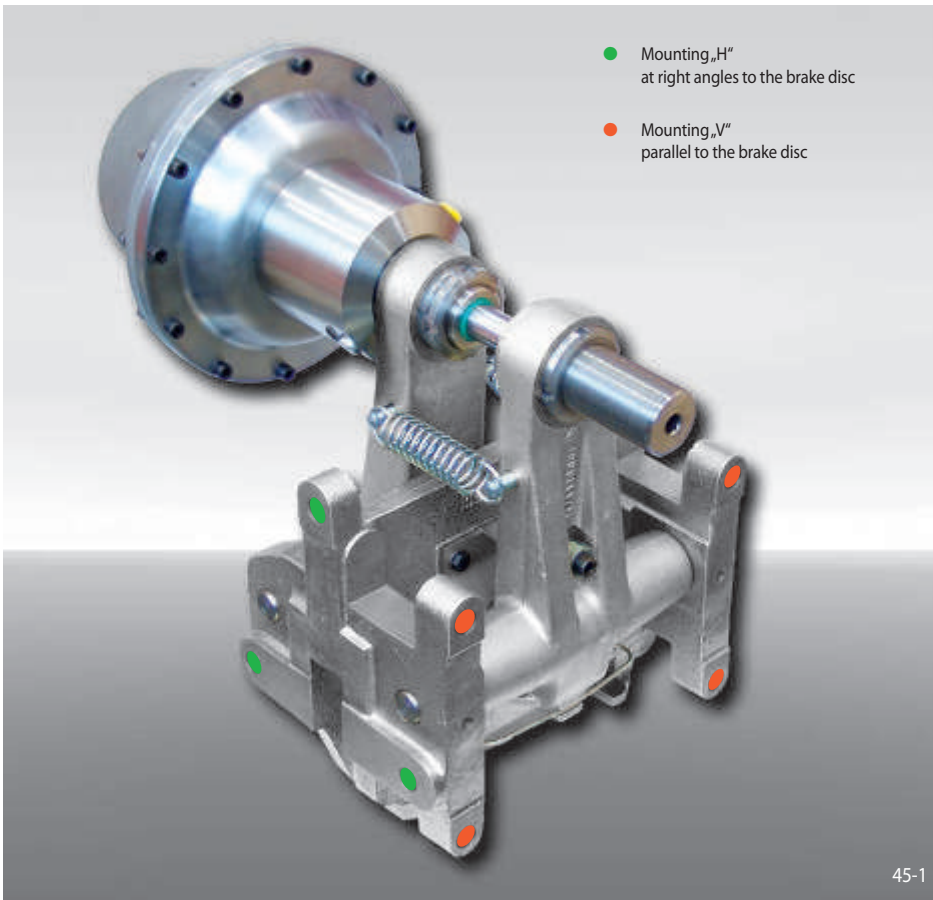

- Mounting „H“ at right angles to the brake disc
- Mounting „V“ parallel to the brake disc

45-1

## Frame Design

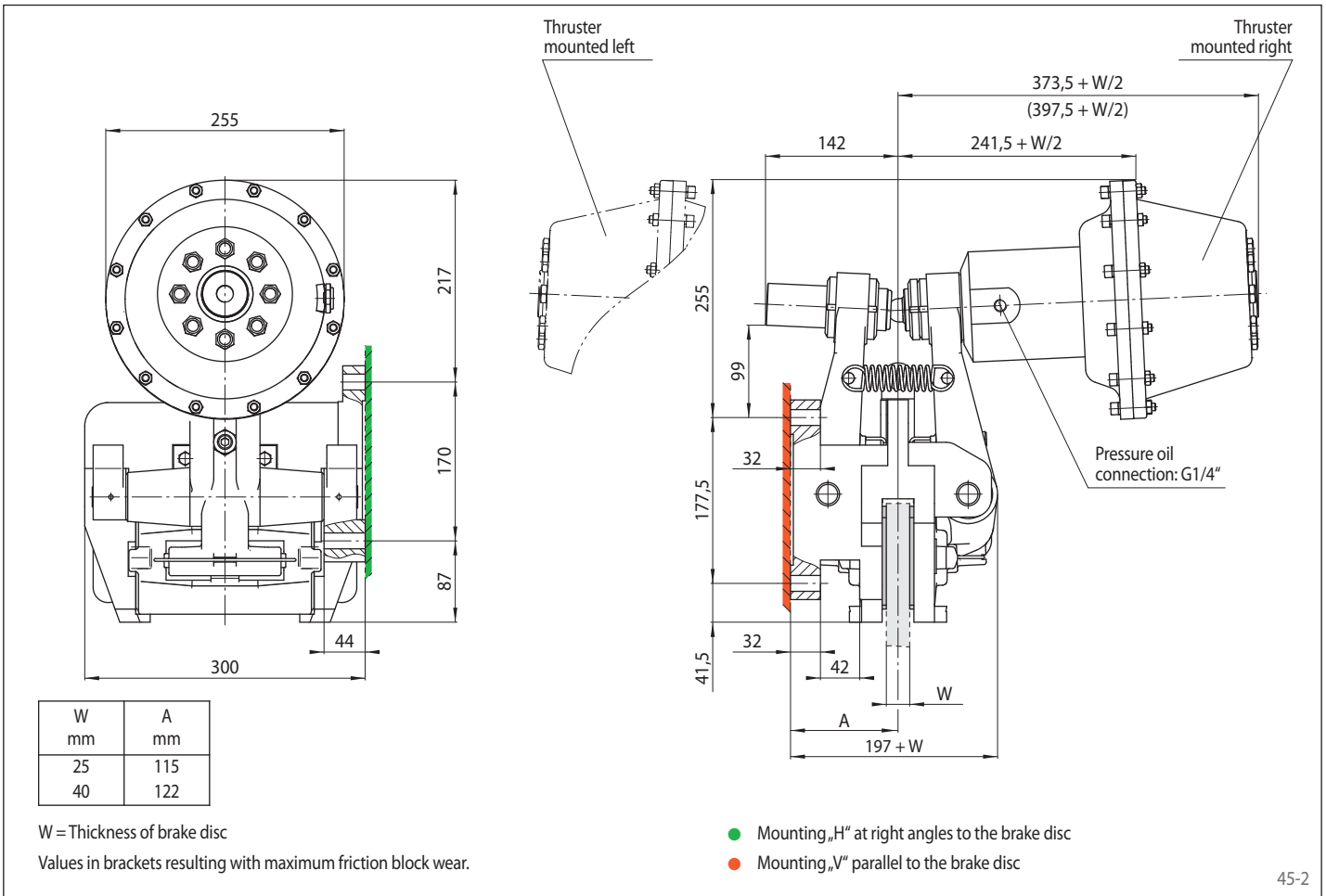
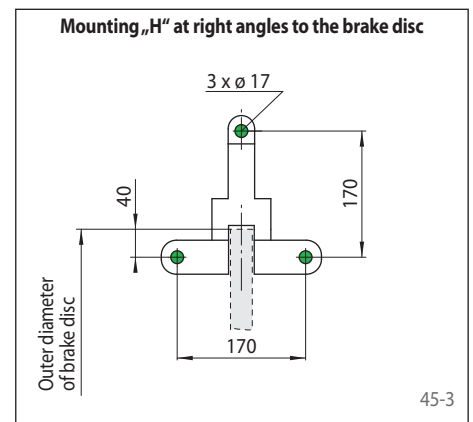
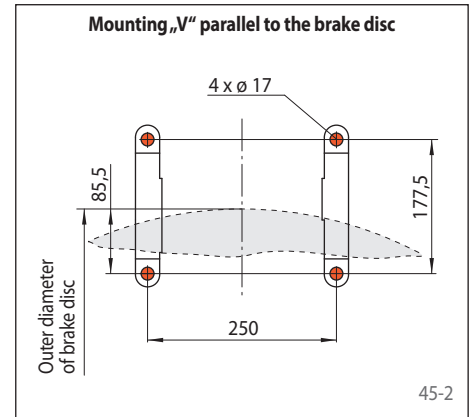

45-2

# Brake Caliper DH 012 FEM

spring activated – electromagnetically released



46-1

## Features

Features	Code
Brake Caliper	D
Mounting to the machine at right angles to the brake disc	H
Frame size 012	012
Spring activated	F
Electromagnetically released	E
Manual adjustment to accommodate friction block wear	M
Electromagnet for 110 V	410
Electromagnet for 230 V	420
Thruster mounted right or left available	R L
Thickness of brake disc 12,5 mm	12

## Example for ordering

Brake Caliper DH 012 FEM, electromagnet for 110 V, thruster mounted right, thickness of brake disc 12,5 mm:

DH 012 FEM - 410 R - 12

## Technical Data

	Brake Caliper DH 012 FEM	
	with electromagnet 410 for 110 V	with electromagnet 420 for 230 V
Brake disc diameter	Braking torque	
mm	Nm	
200	94	
250	130	
300	160	
355	200	
430	250	
520	310	
Clamping force	1650 N	
Power consumption in open position	12 W (100% duty factor)	
Fuse rating	6A	
Switching frequency	600/h permanent activations at 20° C ambient temperature	
Weight	7 kg	

The braking torques shown in the table are based on a theoretical friction coefficient of 0,4.

## Accessories

Universal Transformer see page 120.

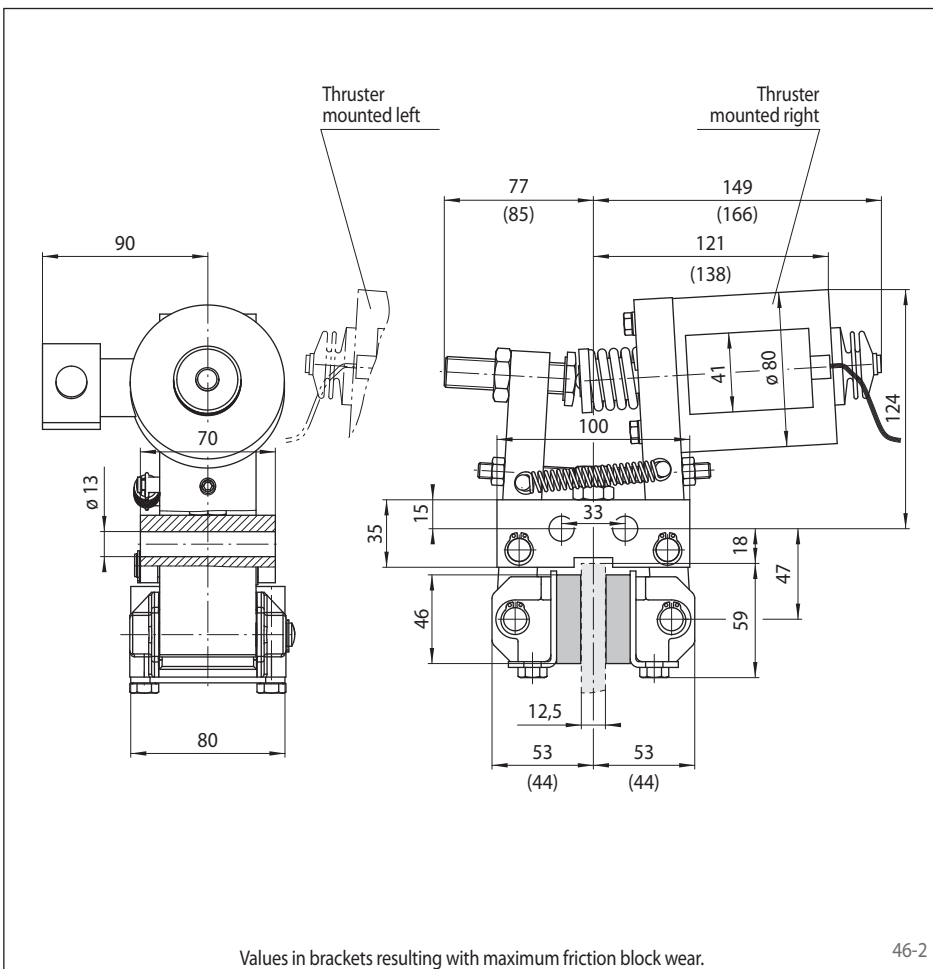

Values in brackets resulting with maximum friction block wear.

46-2



# Brake Caliper DV 020 FEM

spring activated – electromagnetically released

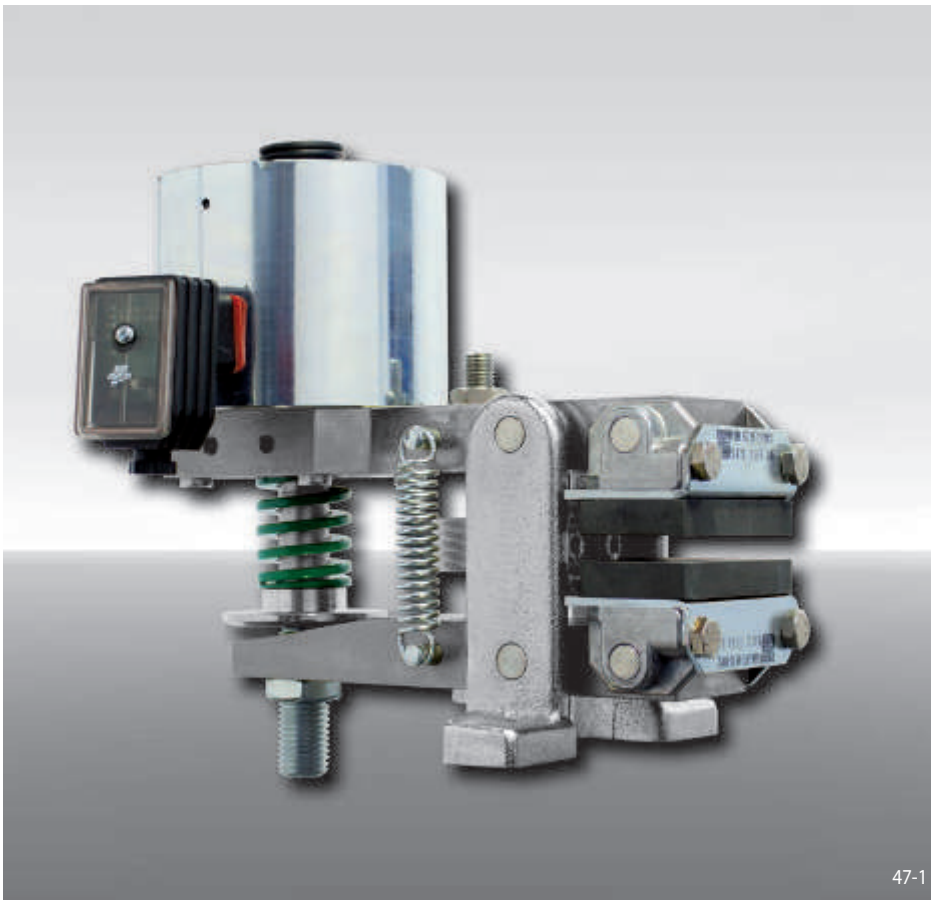

47-1

## Features

Features	Code
Brake Caliper	D
Mounting to the machine parallel to the brake disc	V
Frame size 020	020
Spring activated	F
Electromagnetically released	E
Manual adjustment to accommodate friction block wear	M
Electromagnet for 230 V	430
Thruster mounted right or left available	R L
Thickness of brake disc 12,5 mm	12

## Example for ordering

Brake Caliper DV 020 FEM, electromagnet for 230 V, thruster mounted right, thickness of brake disc 12,5 mm:

DV 020 FEM - 430 R - 12

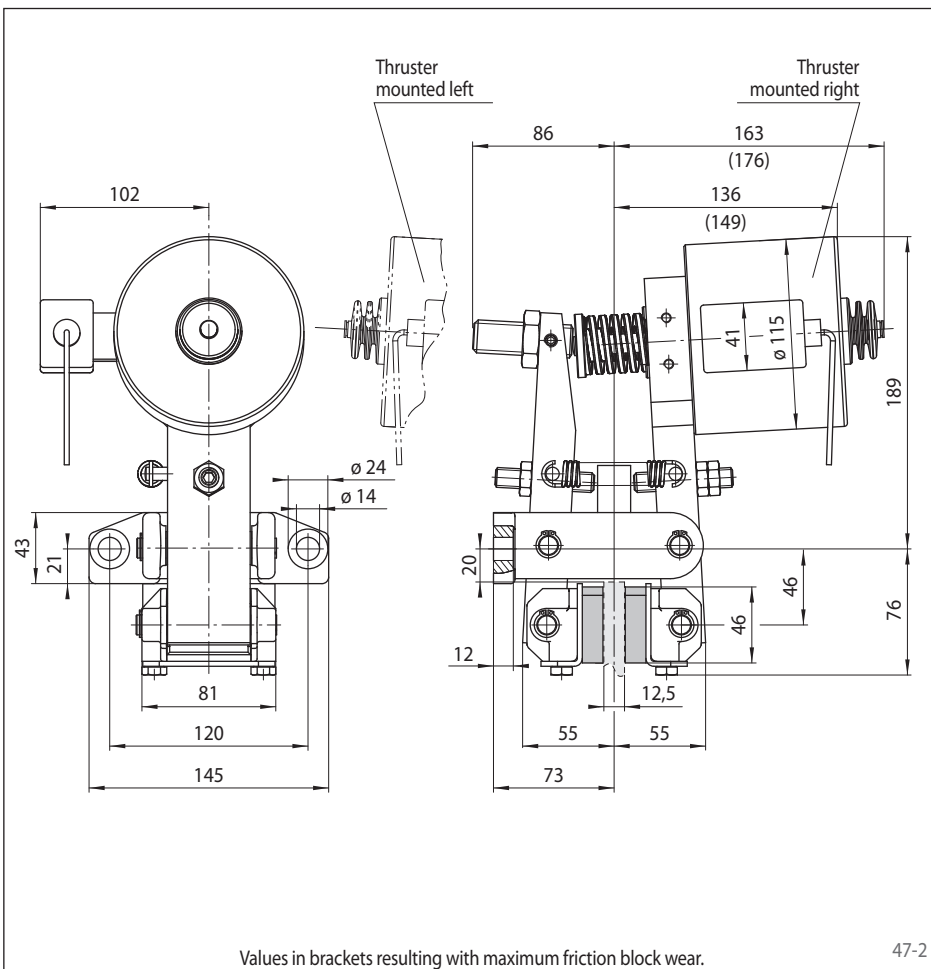

Values in brackets resulting with maximum friction block wear.

47-2

## Technical Data

Brake Caliper DV 020 FEM with electromagnet 430 for 230 V	
Brake disc diameter	Braking torque
mm	Nm
200	180
250	240
300	300
355	370
430	460
520	570
Clamping force	3 100 N
Power consumption in open position	12 W (100% duty factor)
Fuse rating	6A
Switching frequency	800/h permanent activations at 20° C ambient temperature
Weight	15 kg

The braking torques shown in the table are based on a theoretical friction coefficient of 0,4.

## Accessories

Universal Transformer see page 120.

# Brake Calipers EV 018 FEM and EH 018 FEM

spring activated – electromagnetically released

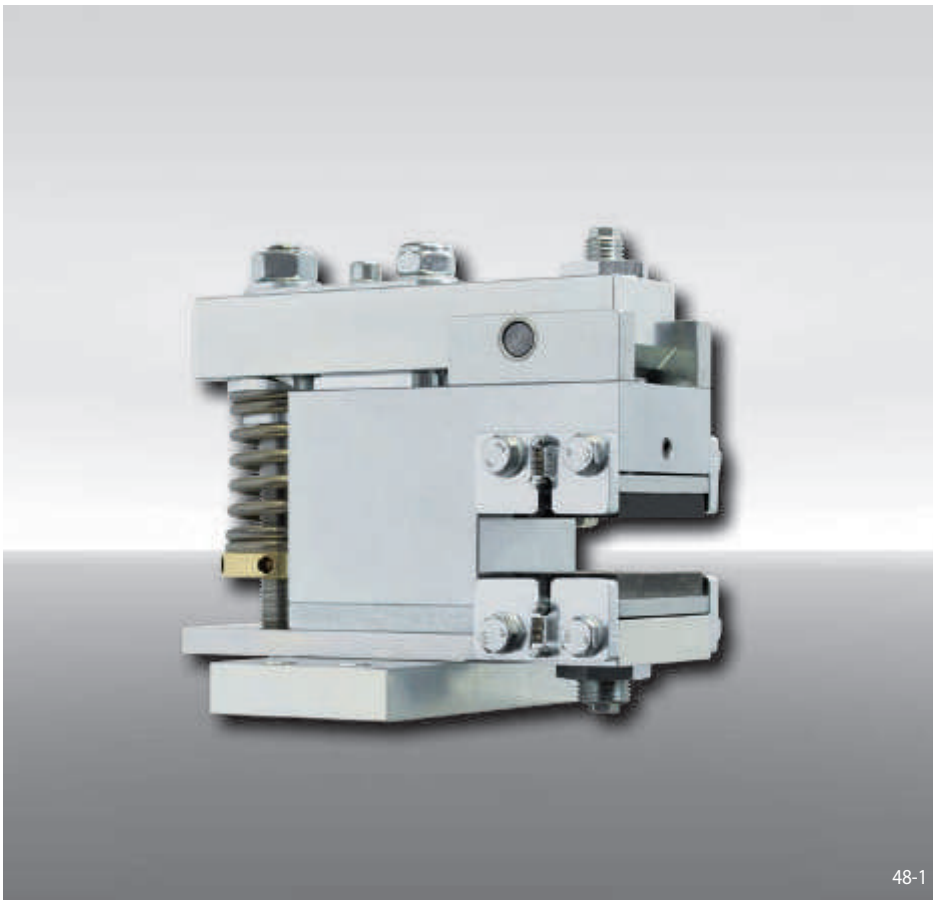

48-1

## Advantages

The brake caliper EV 018 FEM or EH 018 FEM is a very compact and high efficient disc brake with very low power consumption. Its floating bearing compensates small misalignments of the brake disc. The separate electronic module (included) reduces automatically the power consumption in open position to 10 W.

## Options

- Inductive proximity switch: "Brake released"-, "Brake closed"-status and/or "Friction block wear adjustment necessary"

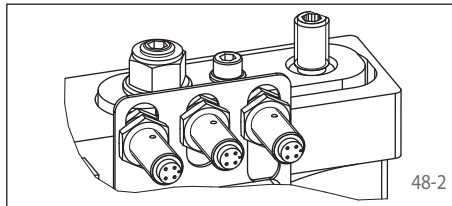

48-2

## Electronic module

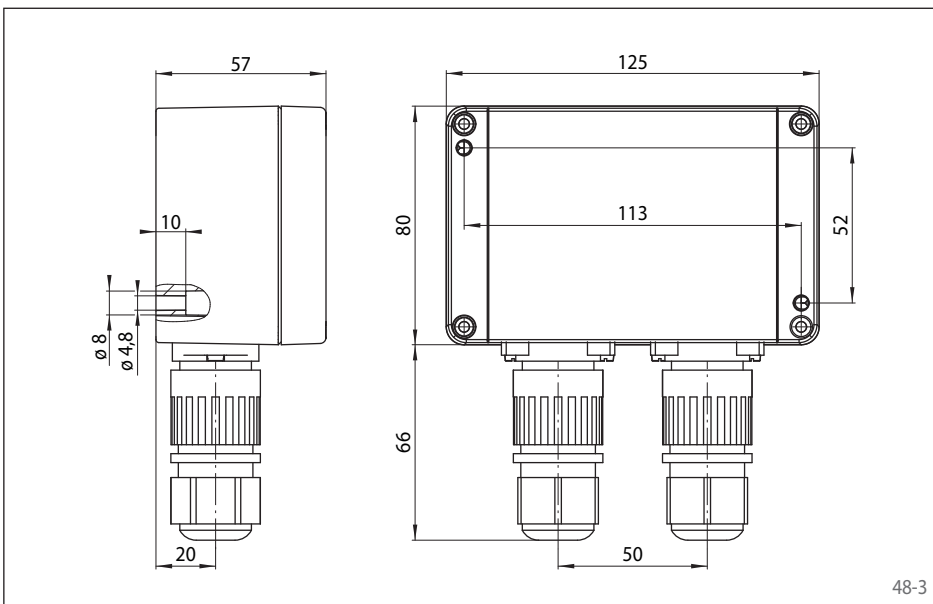

48-3

## Features

Features	Code
Brake Caliper with electromagnet	E
Mounting to the machine parallel or at right angles to the brake disc	V H
Frame size 018	018
Spring activated	F
Electromagnetically released	E
Manual adjustment to accommodate friction block wear	M
Supply voltage 230 to 415 VAC, supply frequency 50 Hz or 60 Hz adjustable	400
Electromagnet mounted in central position	M
Thickness of brake disc 8 ... 15 mm or 16 ... 20 mm	12 20

## Example for ordering

Brake Caliper EV 018 FEM, supply voltage 400 VAC, electromagnet mounted in central position, thickness of brake disc 15 mm:

EV 018 FEM - 400 M - 12

## Technical Data

	Brake Calipers EV 018 FEM and EH 018 FEM with supply voltage	
	230/240 VAC	380/400/415 VAC
Brake disc diameter	Braking torque	Braking torque
mm	Nm	Nm
125	65	90
150	90	120
200	130	180
250	170	240
300	215	295
355	260	360
Clamping force	2 100 N	2 900 N
Clamping force or braking torque adjustable	60 - 100%	50 - 100%
Power consumption in open position	10 W (100% duty factor)	
Fuse rating	16A, time-lag	
Switching frequency	240/h permanent activations at 20° C ambient temperature	
Switching time*	at least 10 seconds	
Weight	6,5 kg	

The braking torques shown in the table are based on a theoretical friction coefficient of 0,4.

\* shorter switching time on request



# Brake Calipers EV 018 FEM and EH 018 FEM

spring activated – electromagnetically released

## Brake Caliper EV 018 FEM

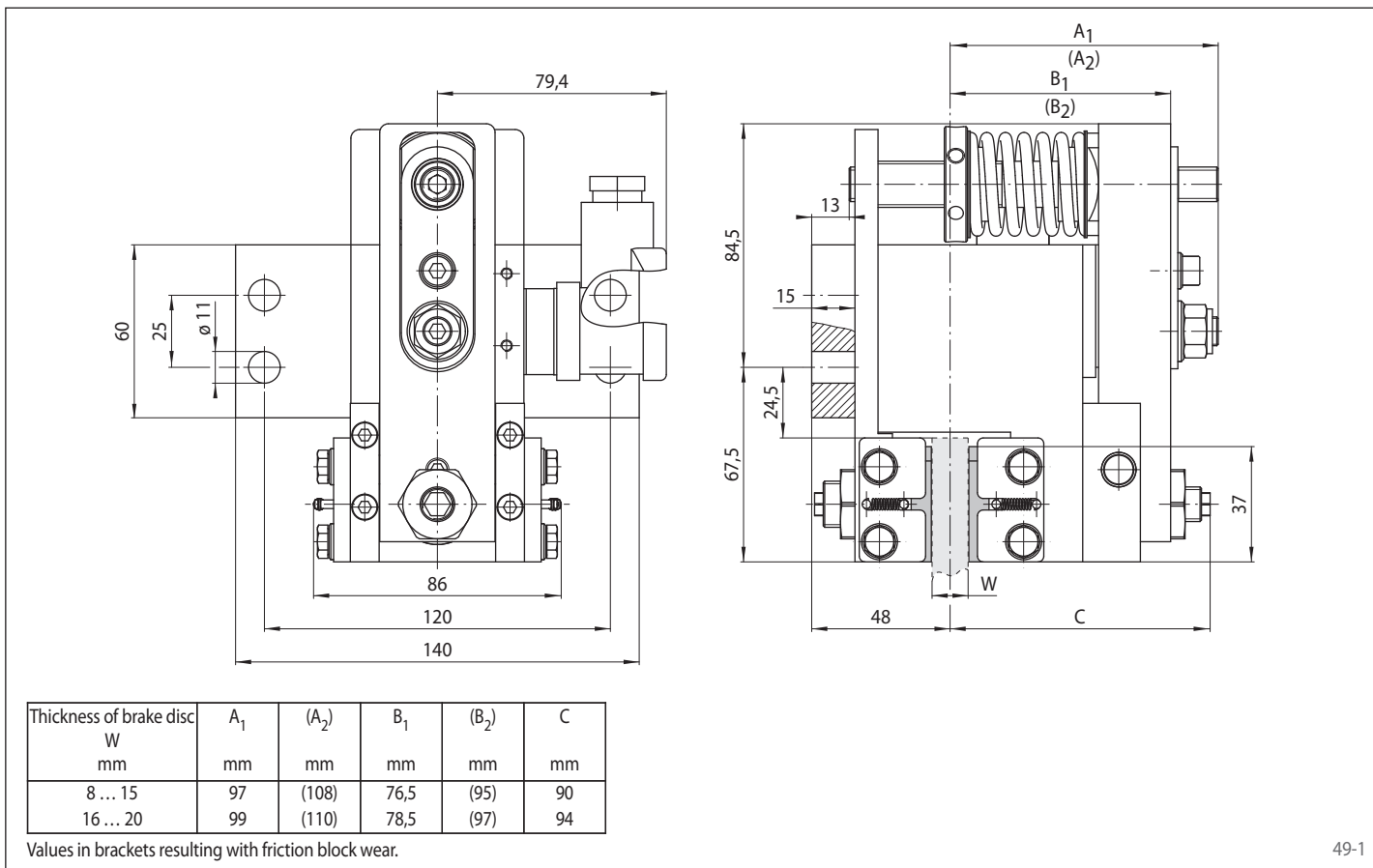

49-1

## Brake Caliper EH 018 FEM

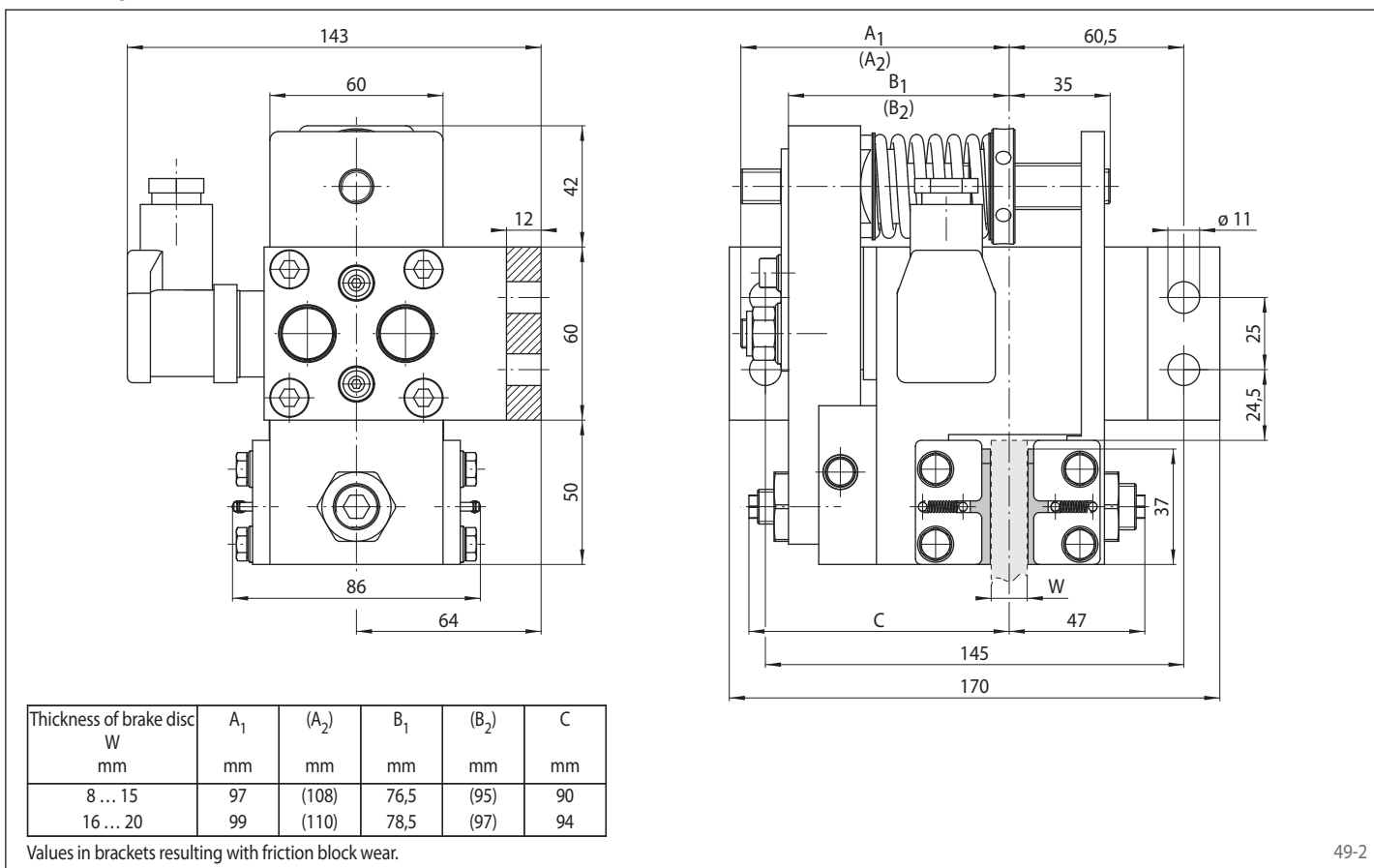

49-2

# Brake Calipers EV 024 FEM and EH 024 FEM

spring activated – electromagnetically released

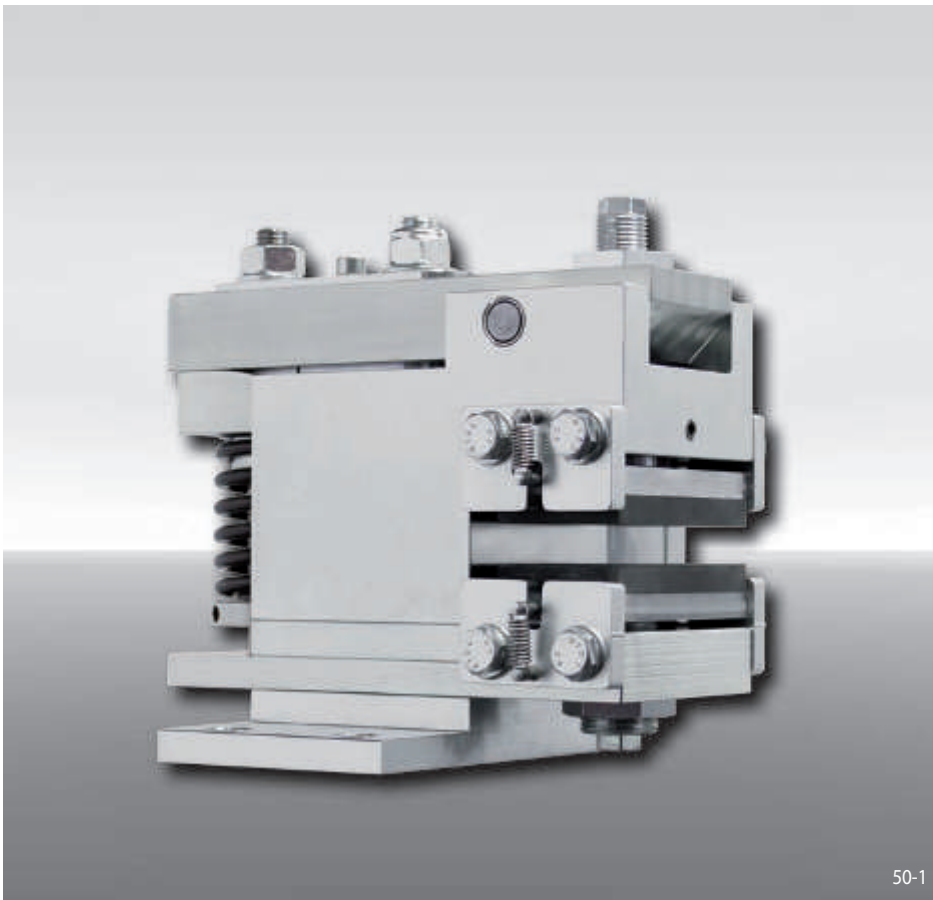

50-1

## Features

Features	Code
Brake Caliper with electromagnet	E
Mounting to the machine parallel or at right angles to the brake disc	V H
Frame size 024	024
Spring activated	F
Electromagnetically released	E
Manual adjustment to accommodate friction block wear	M
Supply voltage 230 to 415 VAC, supply frequency 50 Hz or 60 Hz adjustable	400
Electromagnet mounted in central position	M
Thickness of brake disc 10 ... 16 mm or 18 ... 26 mm	12 25

## Example for ordering

Brake Caliper EV 024 FEM, supply voltage 400 VAC, electromagnet mounted in central position, thickness of brake disc 15 mm:

EV 024 FEM - 400 M - 12

## Advantages

The brake caliper EV 024 FEM or EH 024 FEM is a very compact and high efficient disc brake with very low power consumption. Its floating bearing compensates small misalignments of the brake disc. The attached electronic reduces automatically the power consumption in open position to 10 W.

## Options

- Inductive proximity switch: "Brake released"-, "Brake closed"-status and/or "Friction block wear adjustment necessary"

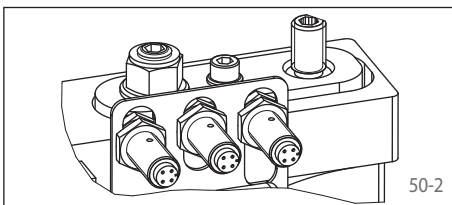

## Technical Data

	Brake Calipers EV 024 FEM and EH 024 FEM with supply voltage	
	230/240 VAC	380/400/415 VAC
Brake disc diameter	Braking torque	Braking torque
mm	Nm	Nm
250	320	400
300	400	500
355	490	610
430	610	760
520	750	940
630	930	1 160
Clamping force	4 000 N	5 000 N
Clamping force or braking torque adjustable	60 - 100%	50 - 100%
Power consumption in open position	10 W (100% duty factor)	
Fuse rating	16A, time-lag	
Switching frequency	240/h permanent activations at 20° C ambient temperature	
Switching time*	at least 10 seconds	
Weight	13 kg	

The braking torques shown in the table are based on a theoretical friction coefficient of 0,4.

\* shorter switching time on request

# Brake Calipers EV 024 FEM and EH 024 FEM

spring activated – electromagnetically released

## Brake Caliper EV 024 FEM

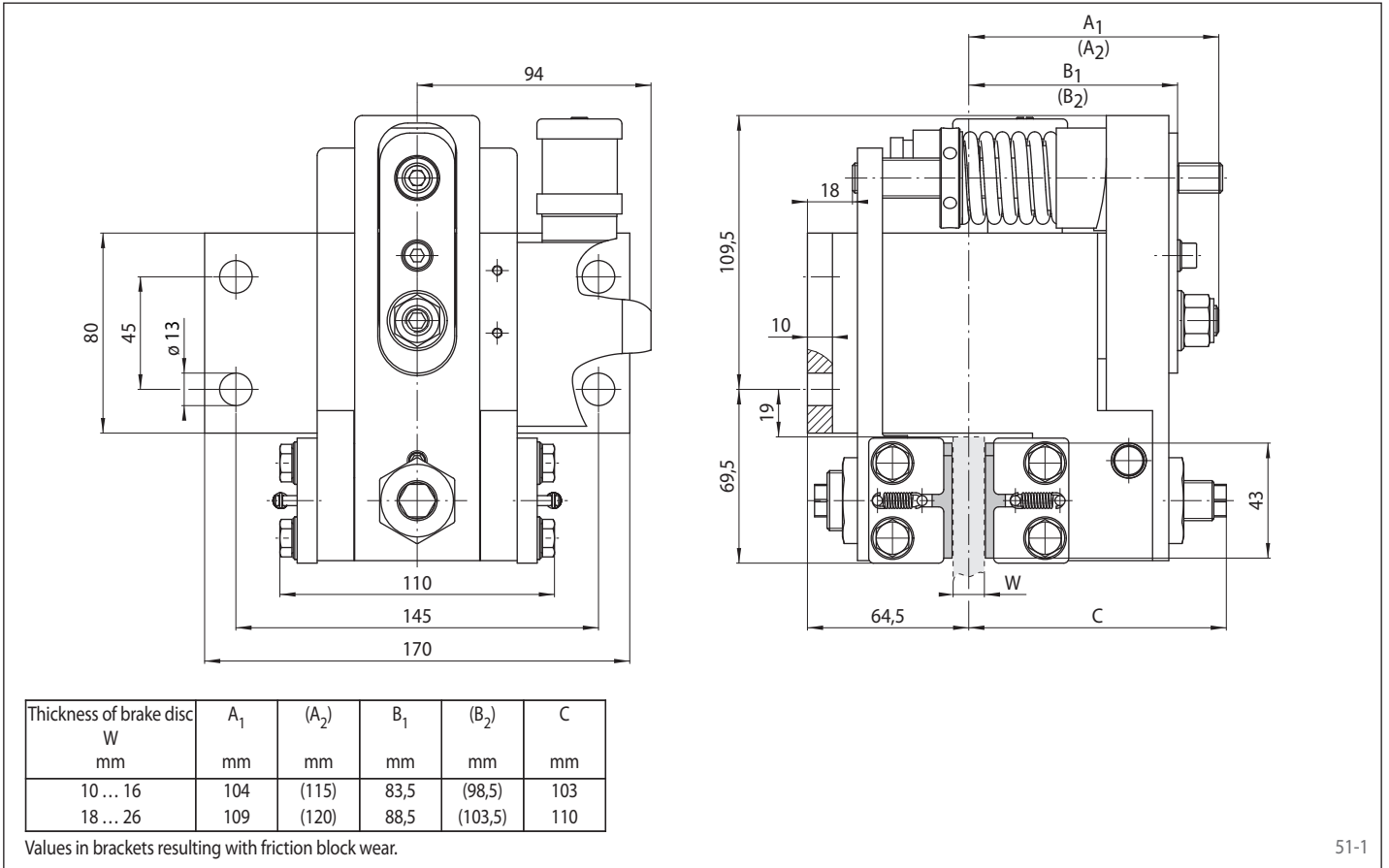

51-1

## Brake Caliper EH 024 FEM

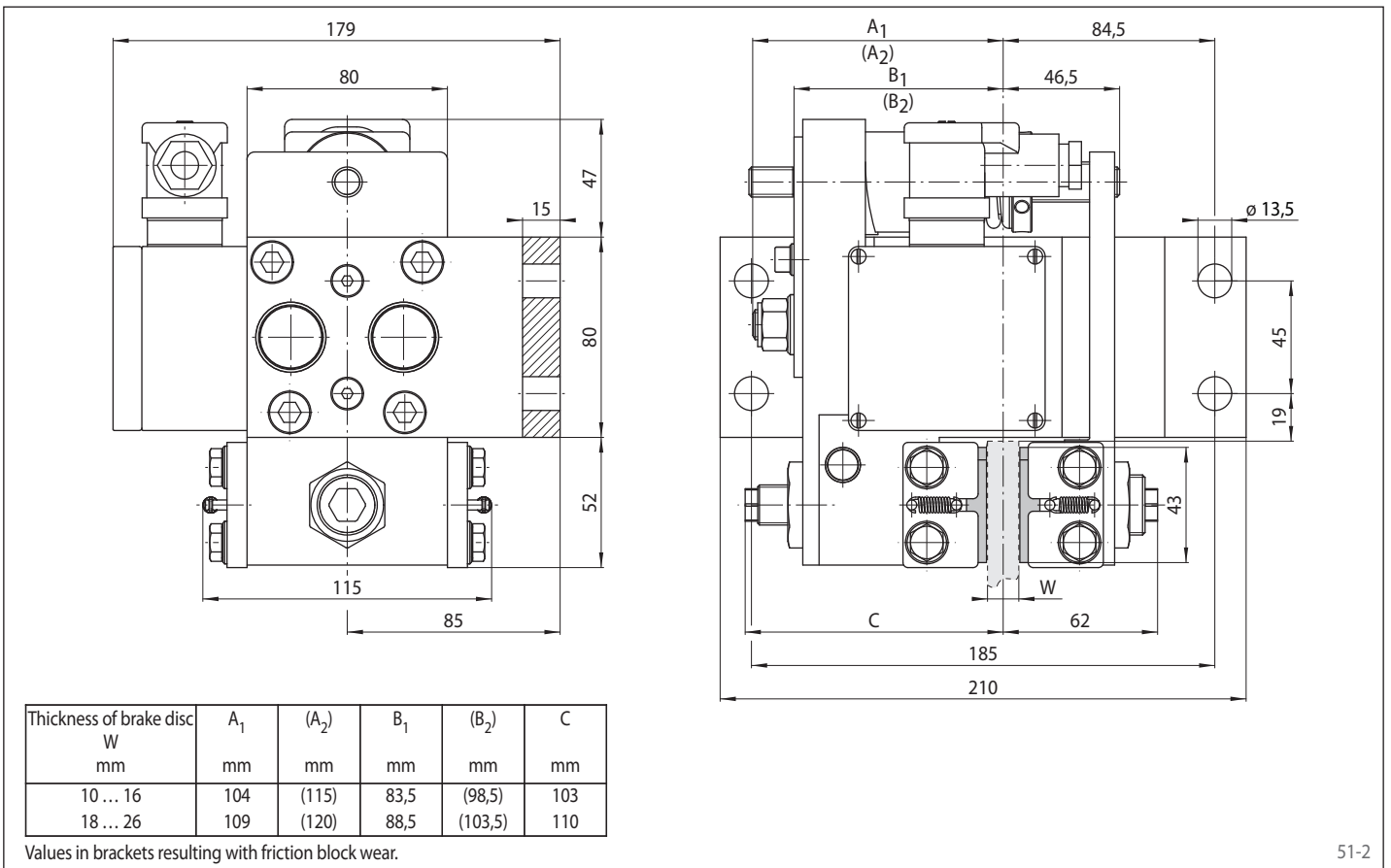

51-2

# Brake Calipers EV 028 FEM and EH 028 FEM

spring activated – electromagnetically released

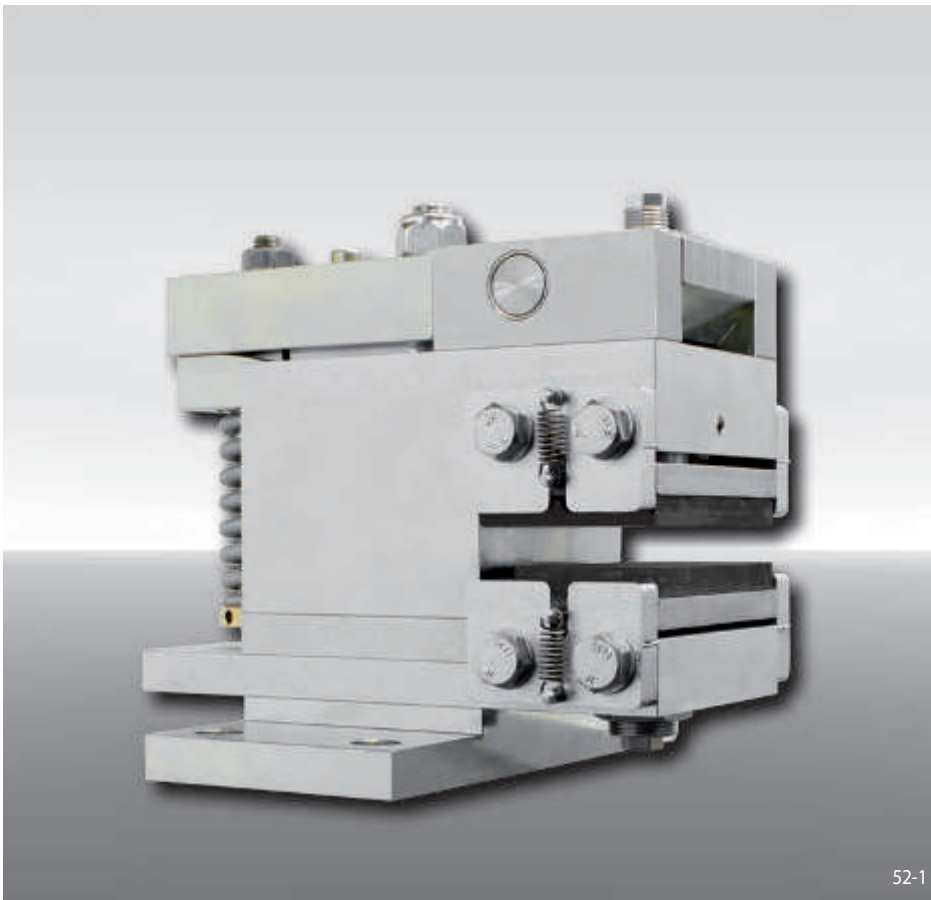

52-1

## Features

Features	Code
Brake Caliper with electromagnet	E
Mounting to the machine parallel or at right angles to the brake disc	V H
Frame size 028	028
Spring activated	F
Electromagnetically released	E
Manual adjustment to accommodate friction block wear	M
Supply voltage 230 to 415 VAC, supply frequency 50 Hz or 60 Hz adjustable	400
Electromagnet mounted in central position	M
Thickness of brake disc 10 ... 16 mm or 18 ... 26 mm	12 25

## Example for ordering

Brake Caliper EV 028 FEM, supply voltage 400 VAC, electromagnet mounted in central position, thickness of brake disc 15 mm:

EV 028 FEM - 400 M - 12

## Advantages

The brake caliper EV 028 FEM or EH 028 FEM is a very compact and high efficient disc brake with very low power consumption. Its floating bearing compensates small misalignments of the brake disc. The attached electronic reduces automatically the power consumption in open position to 20 W.

## Options

- Inductive proximity switch: "Brake released", "Brake closed"-status and/or "Friction block wear adjustment necessary"

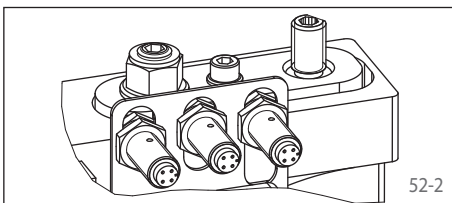

52-2

## Technical Data

	Brake Calipers EV 028 FEM and EH 028 FEM with supply voltage	
	230/240 VAC	380/400/415 VAC
Brake disc diameter	Braking torque	Braking torque
mm	Nm	Nm
300	660	940
355	810	1160
430	1020	1460
520	1270	1820
630	1580	2260
710	1800	2580
Clamping force	7000 N	10000 N
Clamping force or braking torque adjustable	80 - 100%	60 - 100%
Power consumption in open position	20 W (100% duty factor)	
Fuse rating	16A, time-lag	
Switching frequency	240/h permanent activations at 20° C ambient temperature	
Switching time*	at least 10 seconds	
Weight	24 kg	

The braking torques shown in the table are based on a theoretical friction coefficient of 0,4.

\* shorter switching time on request

# Brake Calipers EV 028 FEM and EH 028 FEM

spring activated – electromagnetically released

## Brake Caliper EV 028 FEM

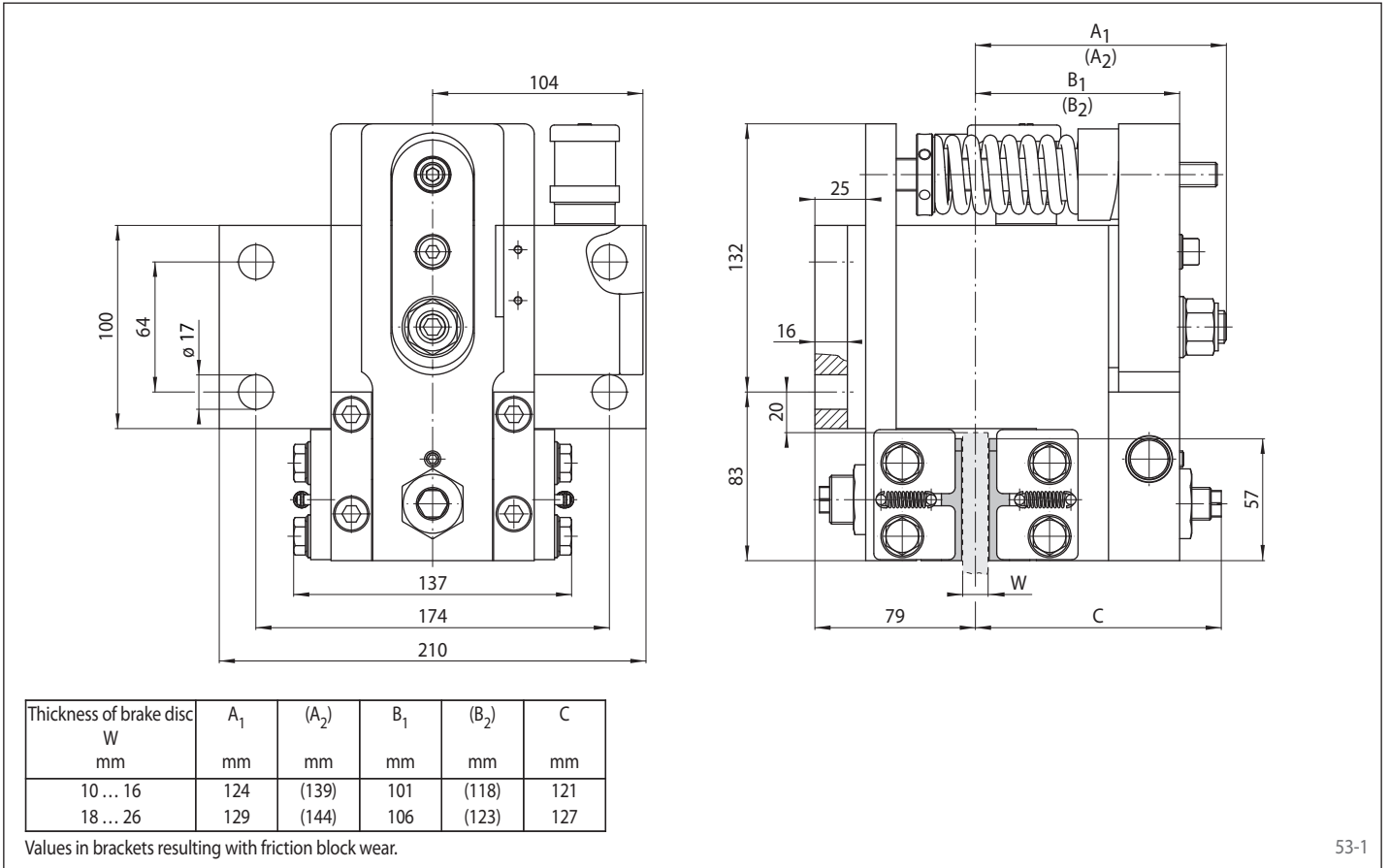

53-1

## Brake Caliper EH 028 FEM

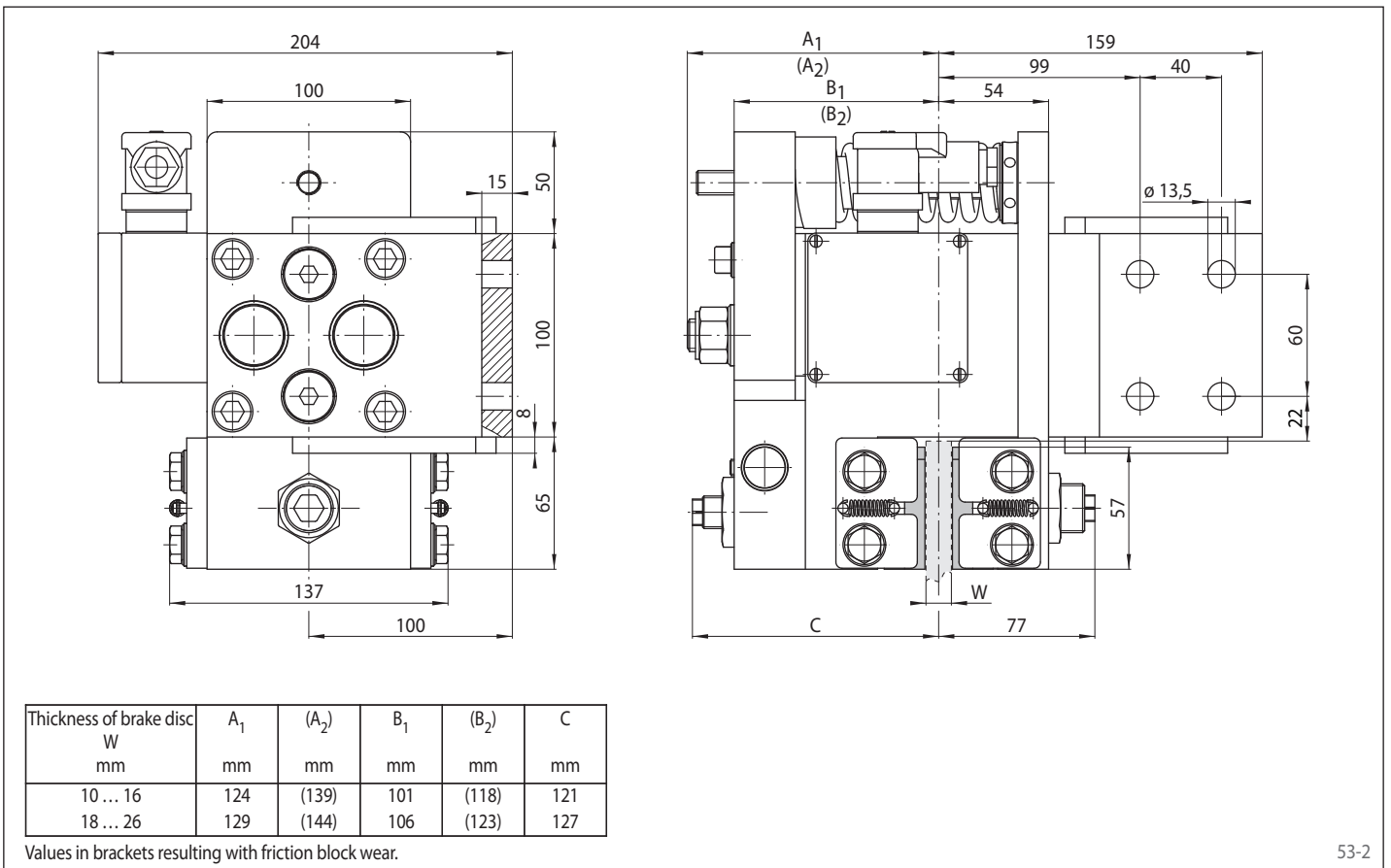

53-2

# Brake Calipers EV 038 FEM and EH 038 FEM

spring activated – electromagnetically released

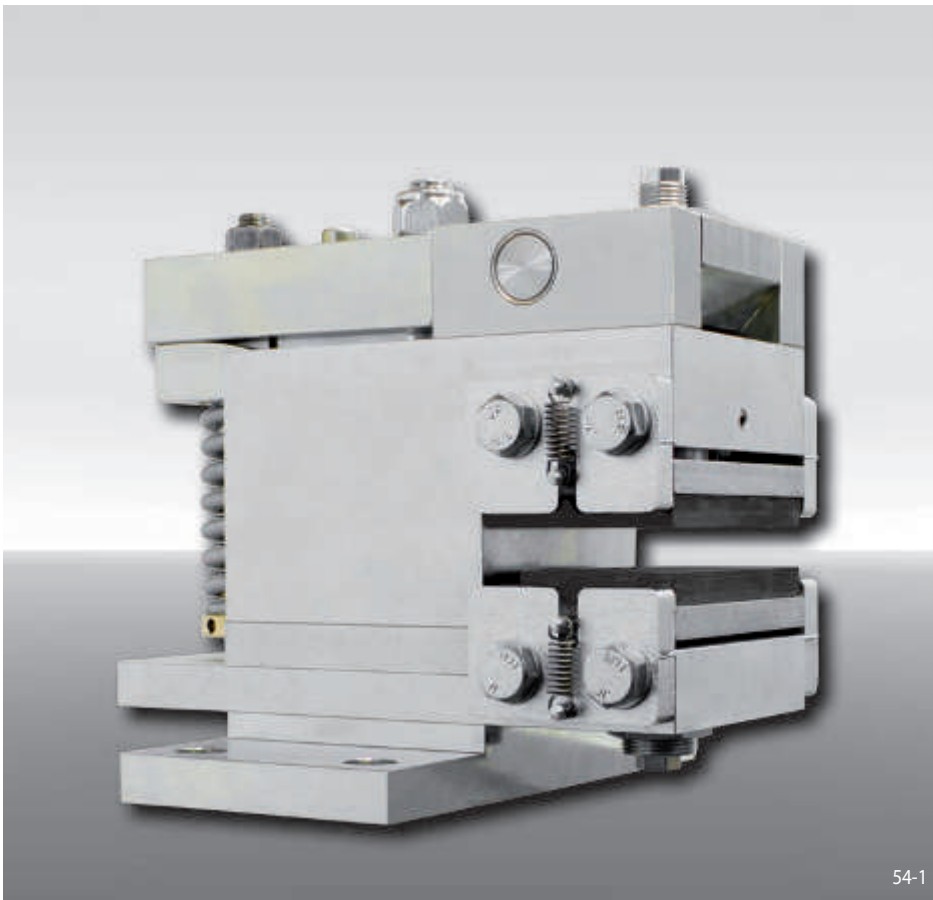

54-1

## Features

Features	Code
Brake Caliper with electromagnet	E
Mounting to the machine parallel or at right angles to the brake disc	V H
Frame size 038	038
Spring activated	F
Electromagnetically released	E
Manual adjustment to accommodate friction block wear	M
Supply voltage 380/400/415 VAC, supply frequency 50 Hz or 60 Hz adjustable	400
Electromagnet mounted in central position	M
Thickness of brake disc 12,5 ... 20 mm or 22 ... 30 mm	12 25

## Example for ordering

Brake Caliper EV 038 FEM, supply voltage 400 VAC, electromagnet mounted in central position, thickness of brake disc 25 mm:

EV 038 FEM - 400 M - 25

## Advantages

The brake caliper EV 038 FEM or EH 038 FEM is a very compact and high efficient disc brake with very low power consumption. Its floating bearing compensates small misalignments of the brake disc. The attached electronic reduces automatically the power consumption in open position to 30 W.

## Options

- Inductive proximity switch: "Brake released", "Brake closed"-status and/or "Friction block wear adjustment necessary"

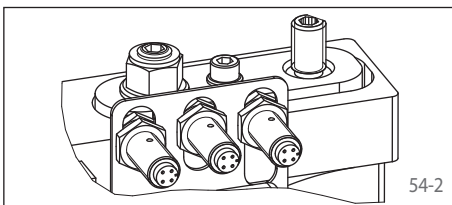

54-2

## Technical Data

Brake Calipers EV 038 FEM and EH 038 FEM with supply voltage 380/400/415 VAC	
Brake disc diameter	Braking torque
mm	Nm
430	2830
520	3550
630	4430
710	5070
800	5790
900	6590
Clamping force	20000 N
Clamping force or braking torque adjustable	60 - 100%
Power consumption in open position	30 W (100% duty factor)
Fuse rating	16A, time-lag
Switching frequency	240/h permanent activations at 20° C ambient temperature
Switching time*	at least 10 seconds
Weight	50 kg

The braking torques shown in the table are based on a theoretical friction coefficient of 0,4.

\* shorter switching time on request

# Brake Calipers EV 038 FEM and EH 038 FEM

spring activated – electromagnetically released

## Brake Caliper EV 038 FEM

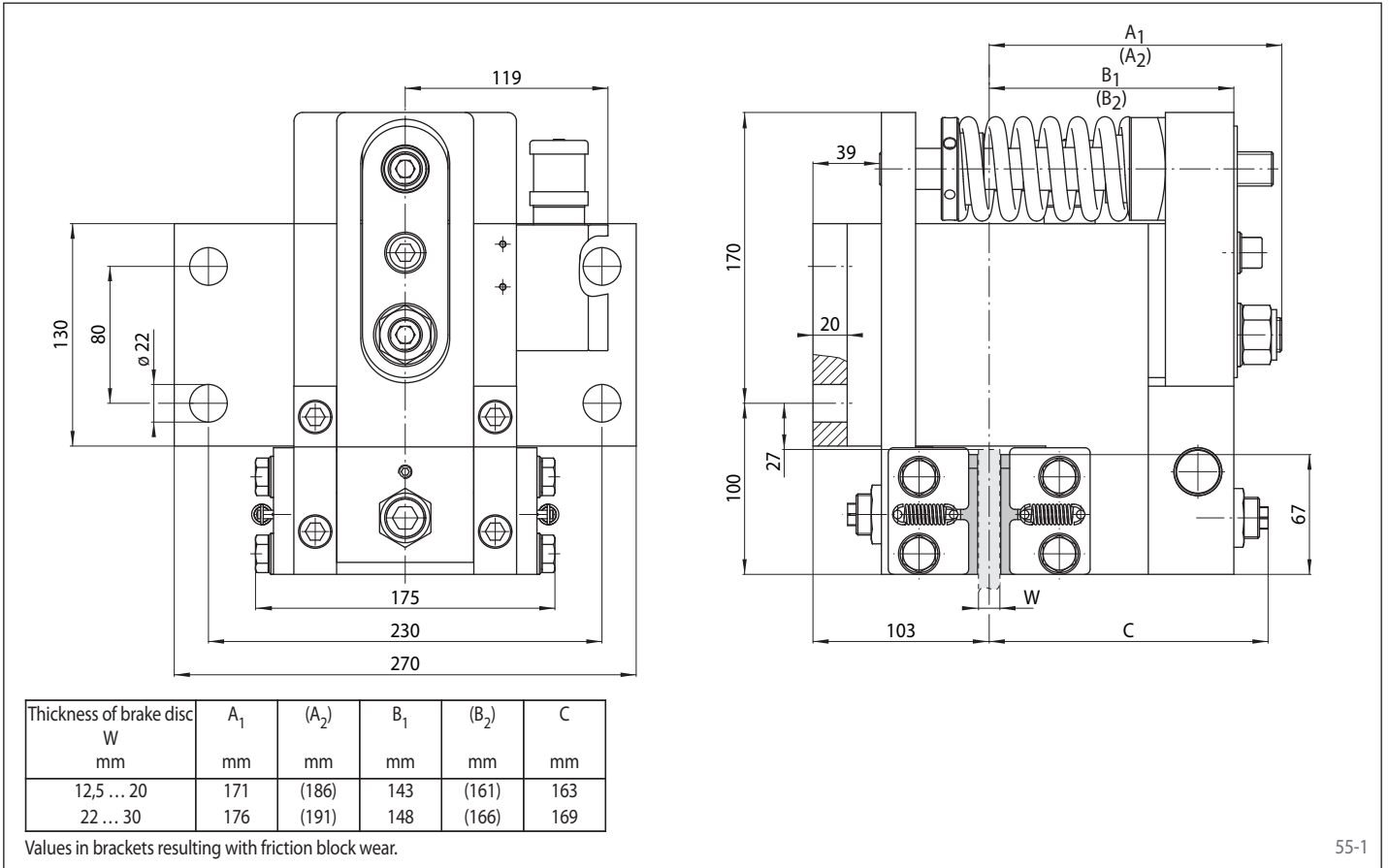

55-1

## Brake Caliper EH 038 FEM

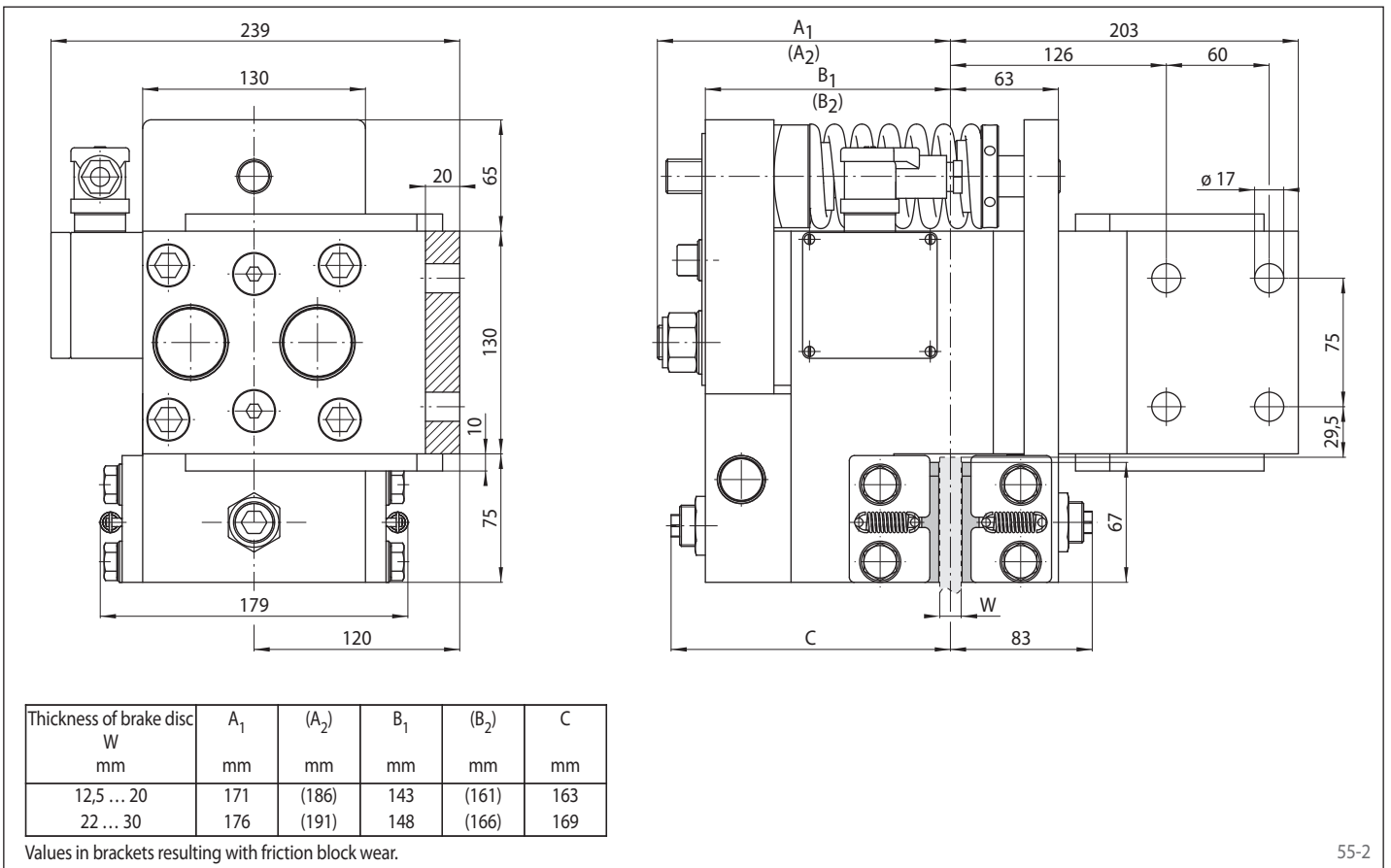

55-2



# Brake Caliper DV 020 FKM

spring activated – manually released  
by Pull Cable

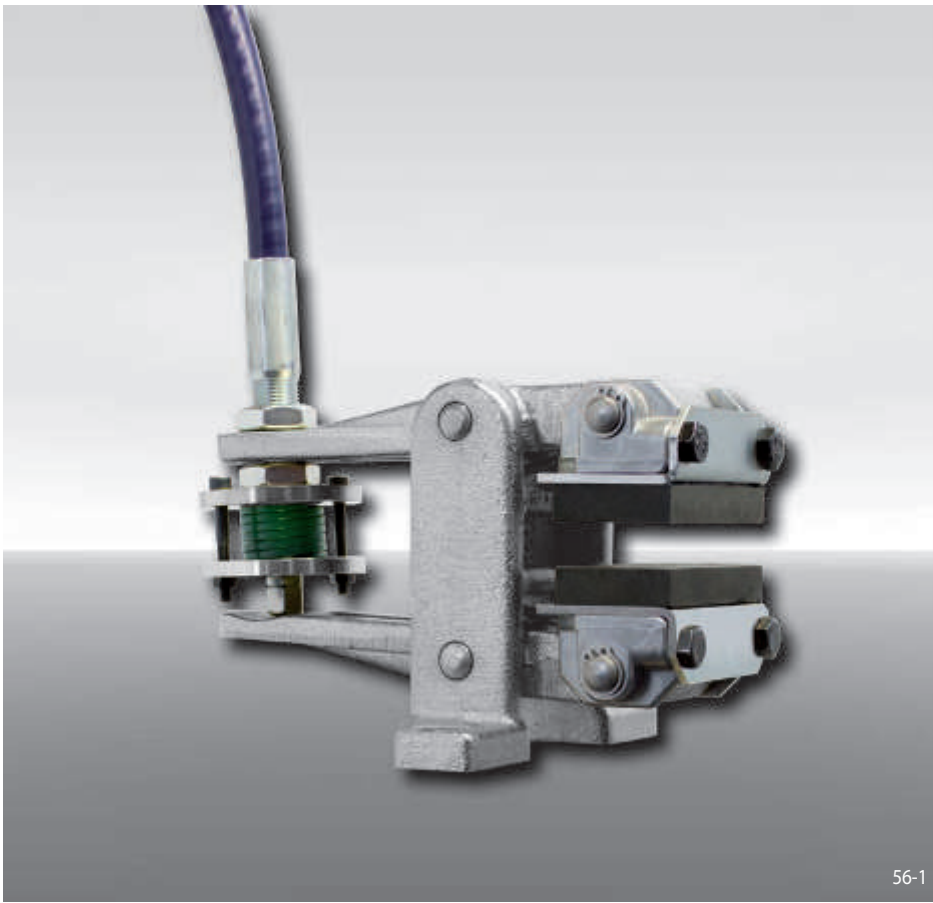

56-1

## Features

Features	Code
Brake Caliper	D
Mounting to the machine parallel to the brake disc	V
Frame size 020	020
Spring activated	F
Manually released	K
Manual adjustment to accommodate friction block wear	M
Pressure spring 510	510
Pull Cable installation mounted right or left available	R L
Thickness of brake disc 12,5 mm	12

## Example for ordering

Brake Caliper DV 020 FKM, pressure spring 510, Pull Cable installation mounted right, thickness of brake disc 12,5 mm:

DV 020 FKM - 510 R - 12

## Technical Data

Brake Caliper DV 020 FKM with pressure spring 510	
Brake disc diameter	Braking torque
mm	Nm
200	160
250	210
300	270
355	330
430	410
520	510
Clamping force	2750 N
Weight	4,4 kg

The braking torques shown in the table are based on a theoretical friction coefficient of 0,4.

## Accessories

The Brake Caliper can be delivered fully assembled with RCS® Pull Cable and Hand Brake Lever. Please indicate the required cable length.

For further information regarding RCS® Pull Cable and Hand Brake Lever see page 121.

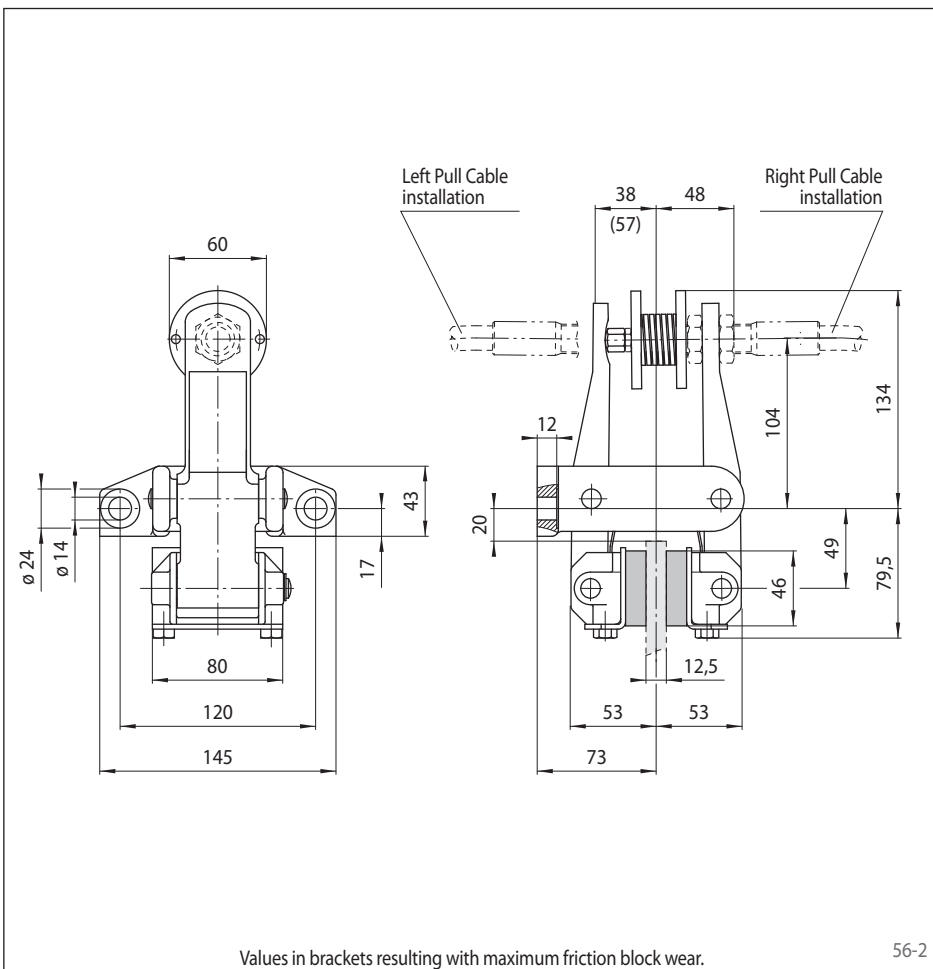

56-2

# Brake Caliper DH 020 FKM

spring activated – manually released  
by Pull Cable

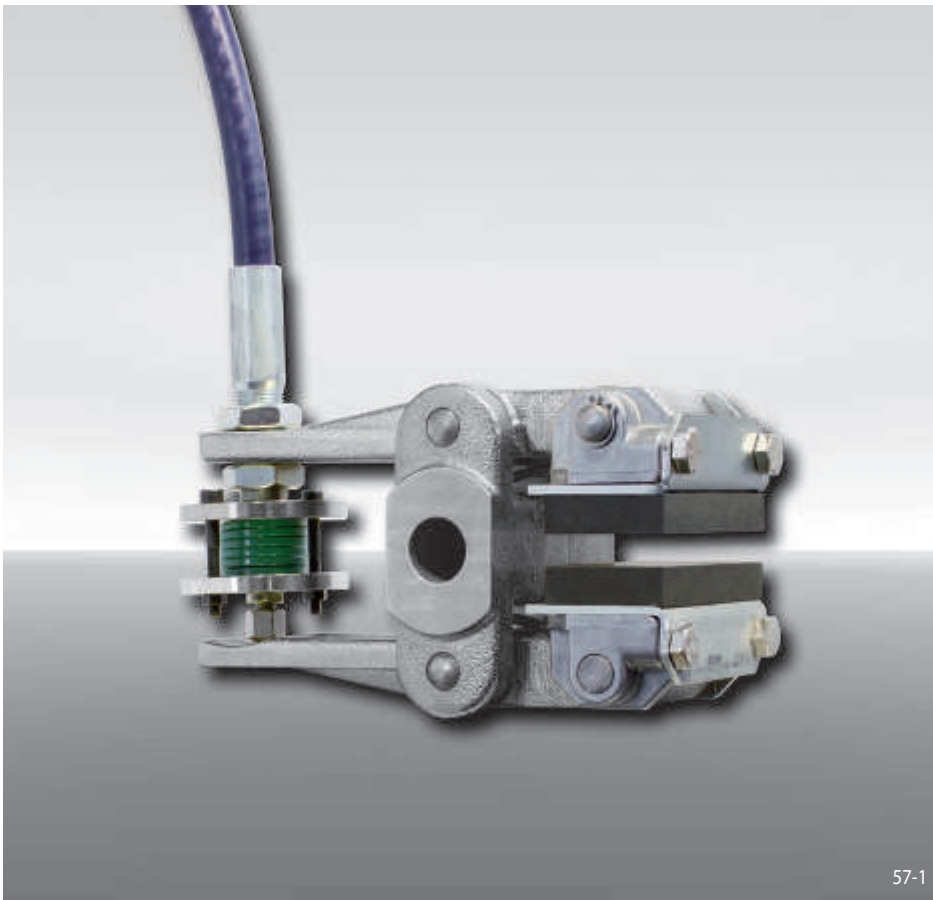

57-1

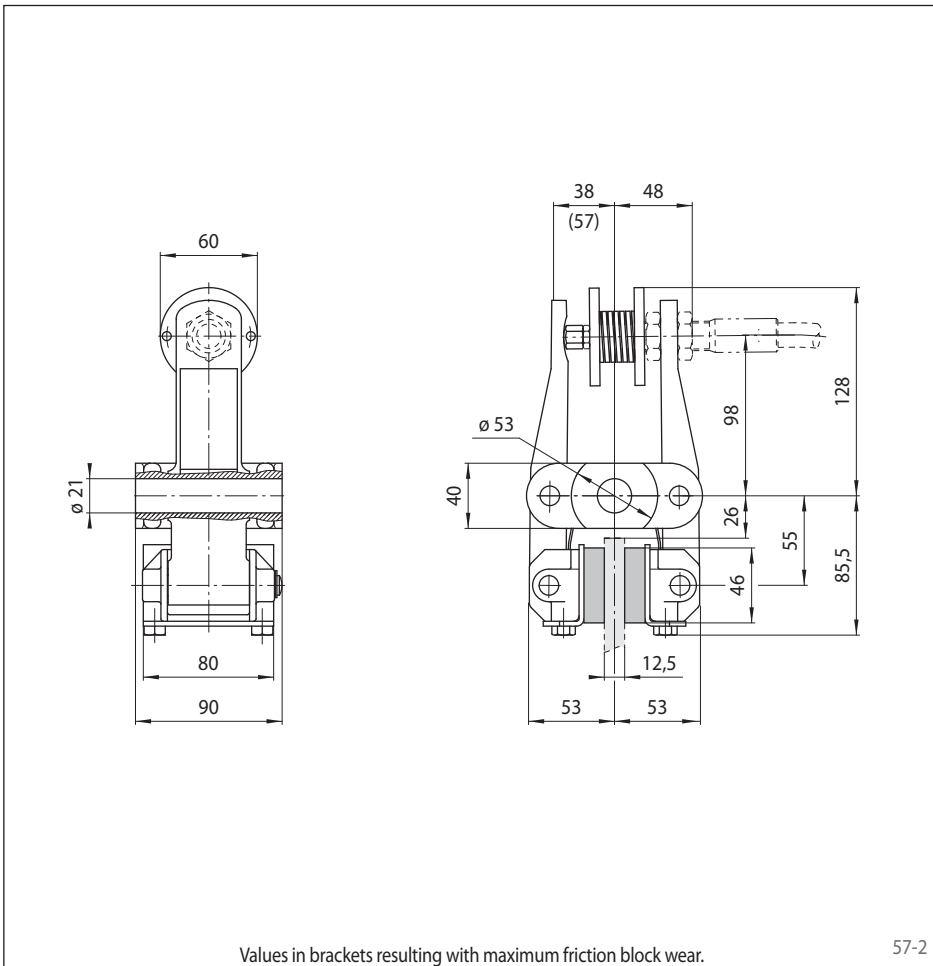

Values in brackets resulting with maximum friction block wear.

57-2

## Features

Features	Code
Brake Caliper	D
Mounting to the machine at right angles to the brake disc	H
Frame size 020	020
Spring activated	F
Manually released	K
Manual adjustment to accommodate friction block wear	M
Pressure spring 510	510
Position of the Pull Cable installation to the right or left can be defined by turning the brake during installation	U
Thickness of brake disc 12,5 mm	12

## Example for ordering

Brake Caliper DH 020 FKM, pressure spring 510, position of the Pull Cable installation can be to the right or left, thickness of brake disc 12,5 mm:

DH 020 FKM - 510 U - 12

## Technical Data

Brake Caliper DH 020 FKM with pressure spring 510	
Brake disc diameter	Braking torque
mm	Nm
200	160
250	210
300	270
355	330
430	410
520	510
Clamping force	2750 N
Weight	4,4 kg

The braking torques shown in the table are based on a theoretical friction coefficient of 0,4.

## Accessories

The Brake Caliper can be delivered fully assembled with RCS® Pull Cable and Hand Brake Lever. Please indicate the required cable length.

For further information regarding RCS® Pull Cable and Hand Brake Lever see page 121.



# Brake Caliper DH 005 PFK

pneumatically activated – spring released



59-1

## Features

Features	Code
Brake Caliper	D
Mounting to the machine at right angles to the brake disc	H
Frame size 005	005
Pneumatically activated	P
Spring released	F
No adjustment to accommodate friction block wear	K
Pressure piston 605	605
Pressure piston mounted in central position	M
Thickness of brake disc 6 mm	06

## Example for ordering

Brake Caliper DH 005 PFK, pressure piston 605, pressure piston mounted in central position, thickness of brake disc 6 mm:

DH 005 PFK - 605 M - 06

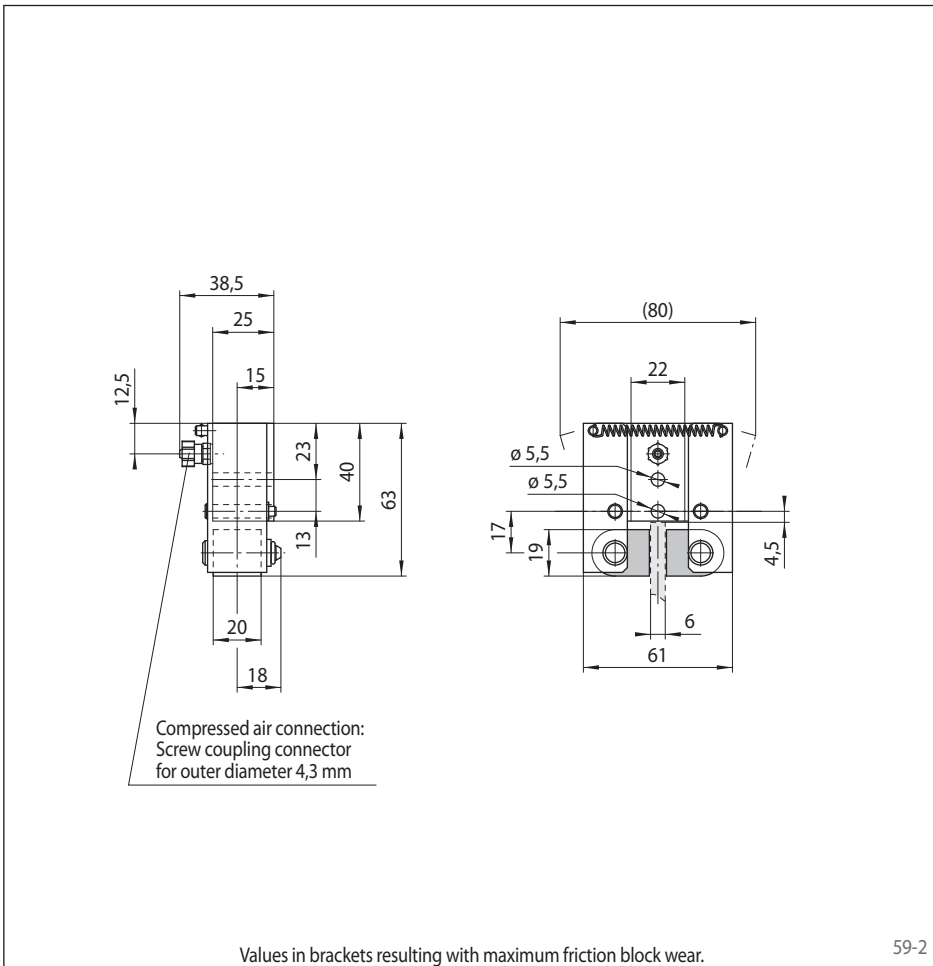

59-2

## Technical Data

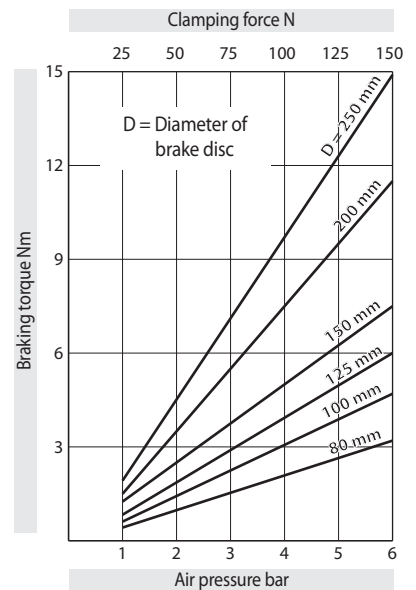

The braking torques shown in the diagram are based on a theoretical friction coefficient of 0,4.

Air pressure: max. 6 bar

Air volume: max. 3 cm<sup>3</sup> per activation

Weight: 0,4 kg

# Brake Caliper DH 010 PFK

pneumatically activated – spring released



60-1

## Features

Features	Code
Brake Caliper	D
Mounting to the machine at right angles to the brake disc	H
Frame size 010	010
Pneumatically activated	P
Spring released	F
No adjustment to accommodate friction block wear	K
Pressure piston 610	610
Pressure piston mounted in central position	M
Thickness of brake disc 12,5 mm	12

## Example for ordering

Brake Caliper DH 010 PFK, pressure piston 610, pressure piston mounted in central position, thickness of brake disc 12,5 mm:

DH 010 PFK - 610 M - 12

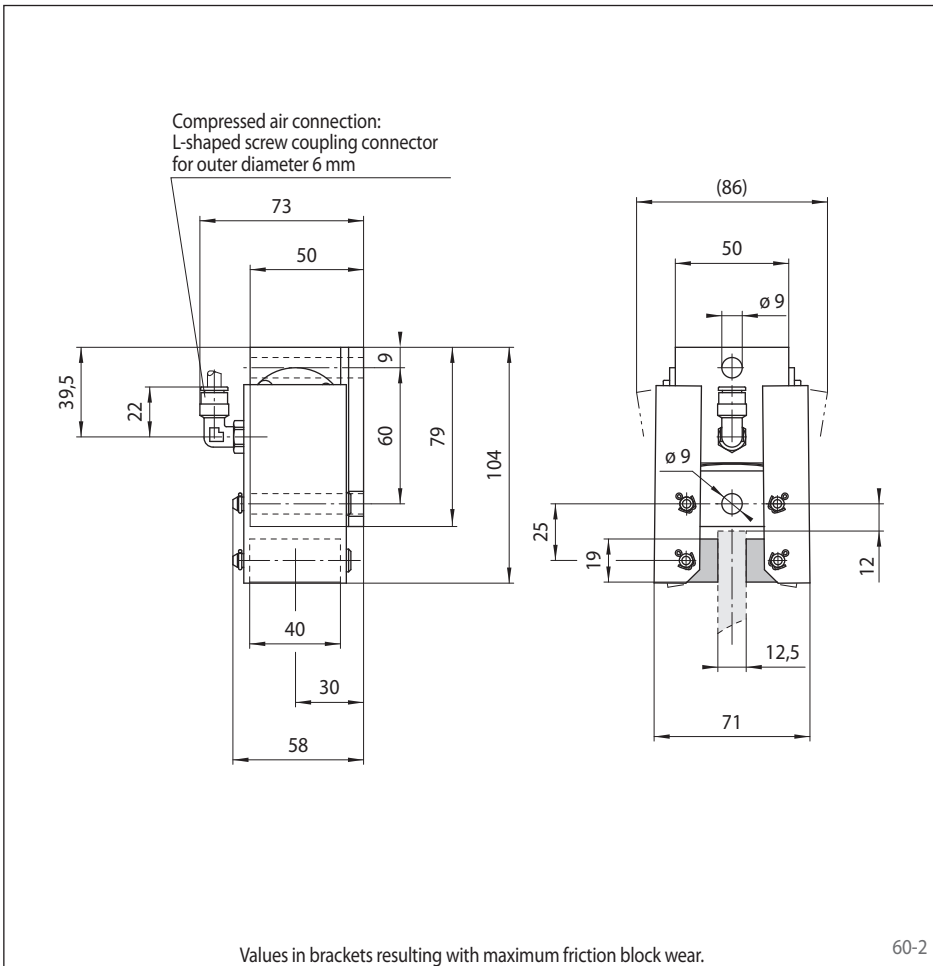

60-2

## Technical Data

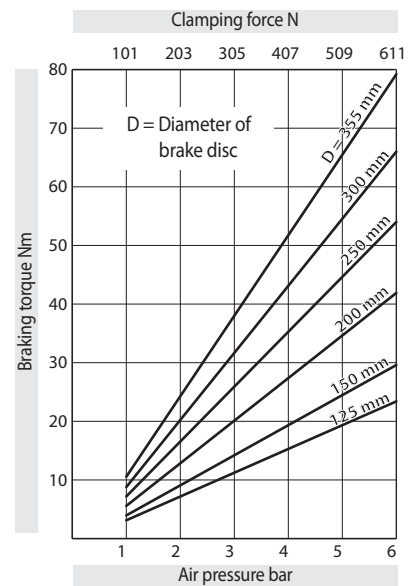

The braking torques shown in the diagram are based on a theoretical friction coefficient of 0,4.

Air pressure: max. 6 bar

Air volume: max. 10 cm<sup>3</sup> per activation

Weight: 1,1 kg

# Brake Caliper DH 015 PFK

pneumatically activated – spring released

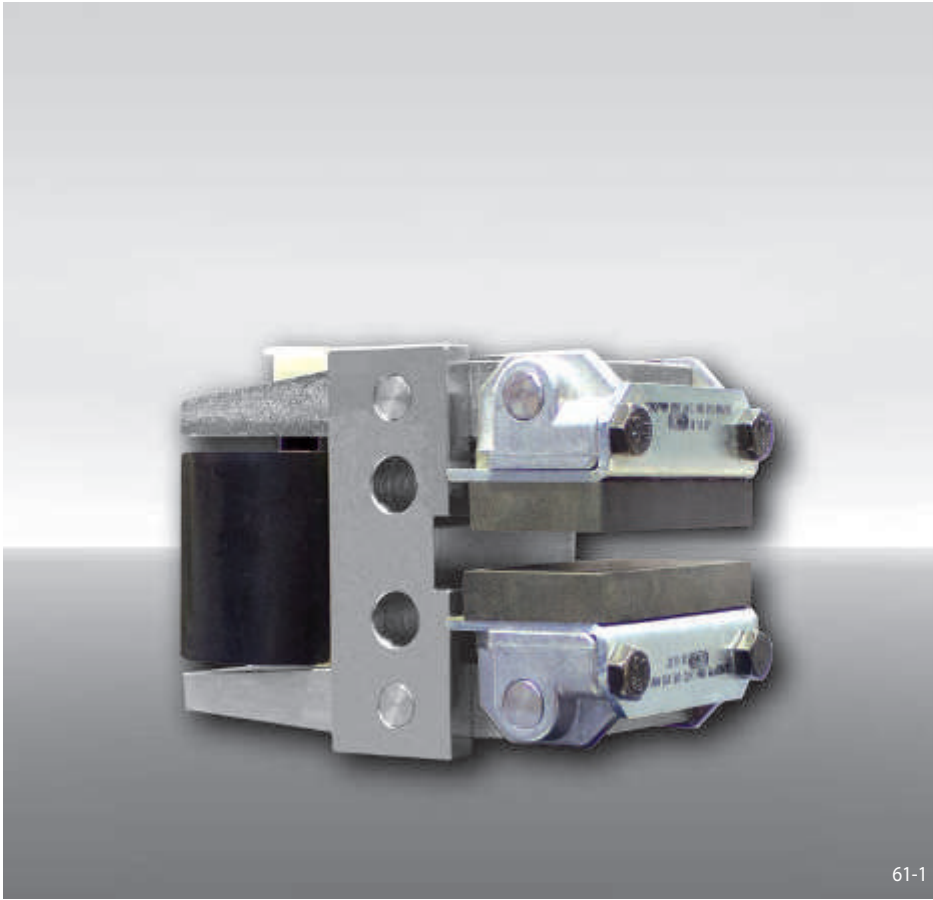

61-1

## Features

Features	Code
Brake Caliper	D
Mounting to the machine at right angles to the brake disc	H
Frame size 015	015
Pneumatically activated	P
Spring released	F
No adjustment to accommodate friction block wear	K
Thruster 620	620
Thruster mounted in central position	M
Thickness of brake disc 12,5 mm	12

## Example for ordering

Brake Caliper DH 015 PFK, thruster 620, thruster mounted in central position, thickness of brake disc 12,5 mm:

DH 015 PFK - 620 M - 12

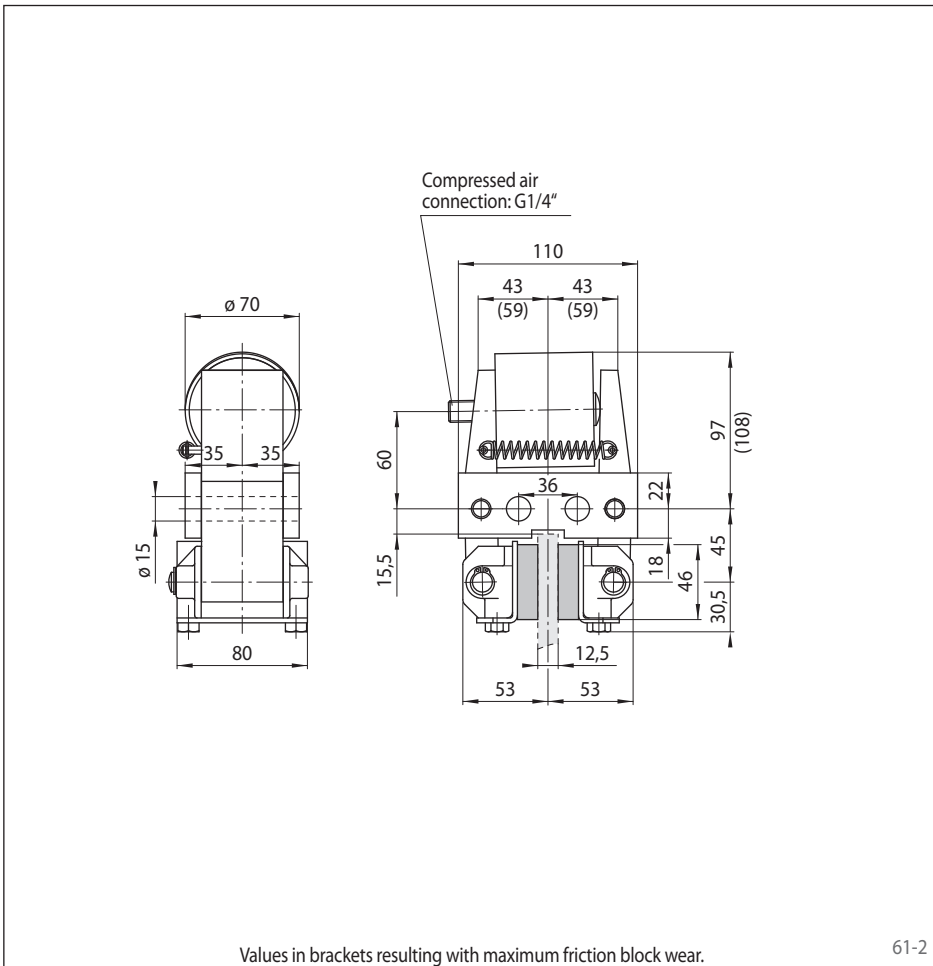

Values in brackets resulting with maximum friction block wear.

61-2

## Technical Data

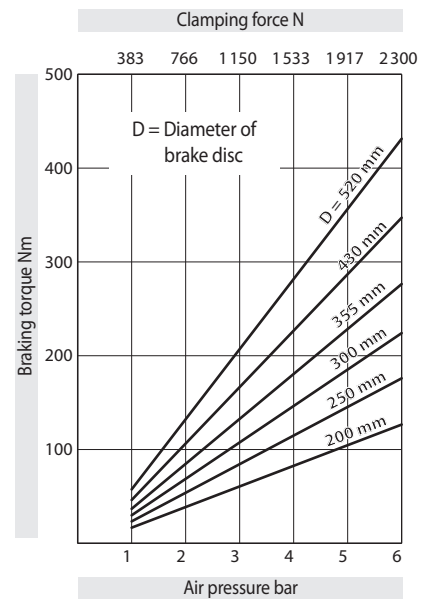

The braking torques shown in the diagram are based on a theoretical friction coefficient of 0,4.

Air pressure: max. 6 bar

Air volume: max. 124 cm<sup>3</sup> per activation

Weight: 4,6 kg



# Brake Caliper DV 020 PFK

pneumatically activated – spring released

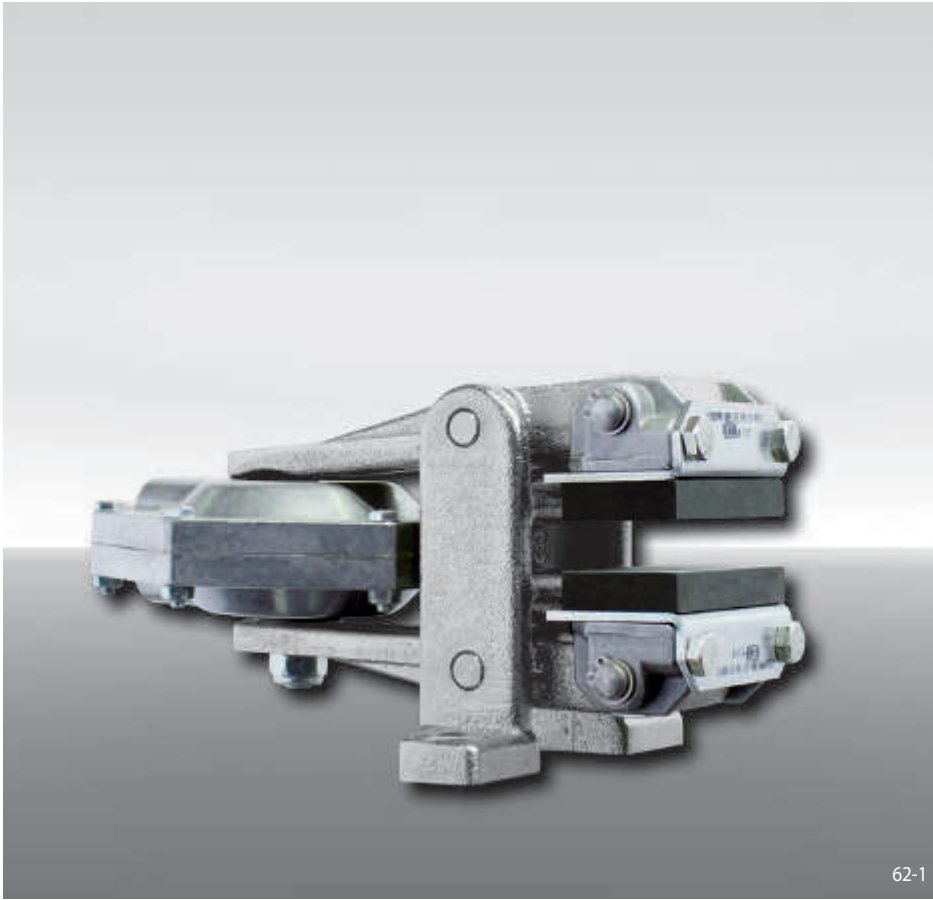

62-1

## Features

Features	Code
Brake Caliper	D
Mounting to the machine parallel to the brake disc	V
Frame size 020	020
Pneumatically activated	P
Spring released	F
No adjustment to accommodate friction block wear	K
Thruster 630	630
Thruster mounted in central position	M
Thickness of brake disc 12,5 mm	12

## Example for ordering

Brake Caliper DV 020 PFK, thruster 630, thruster mounted in central position, thickness of brake disc 12,5 mm:

DV 020 PFK - 630 M - 12

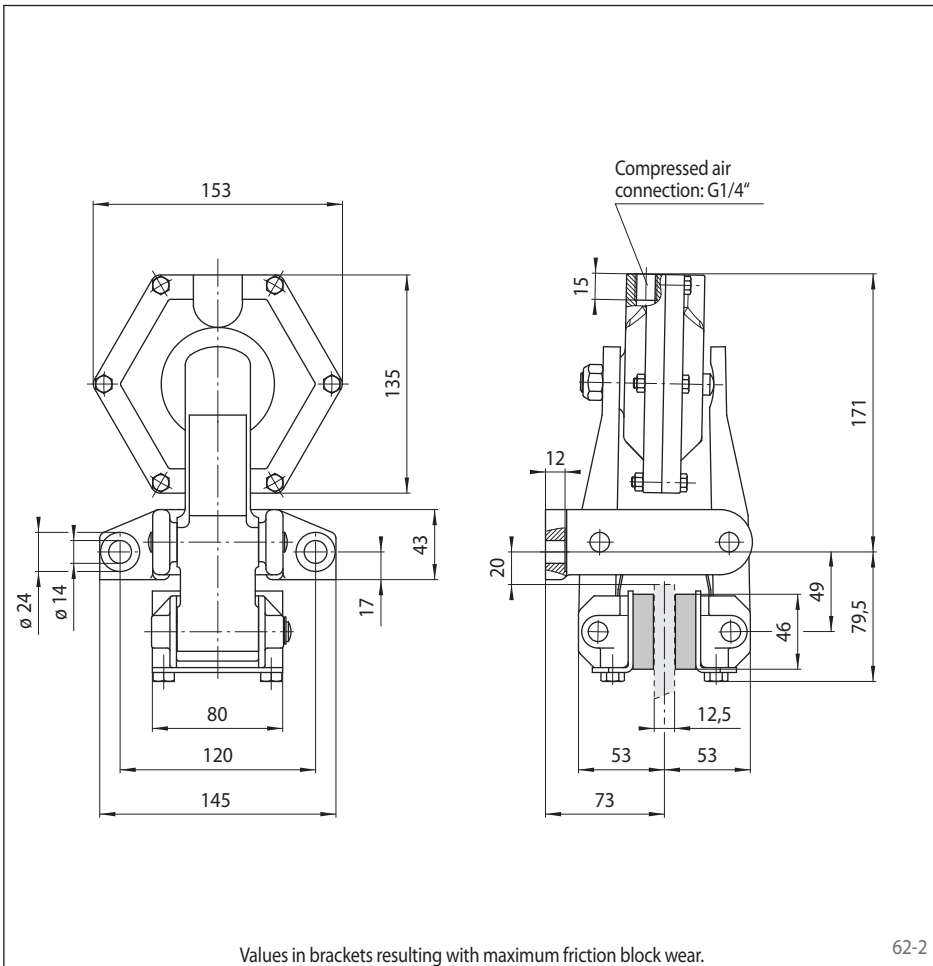

Values in brackets resulting with maximum friction block wear.

62-2

## Technical Data

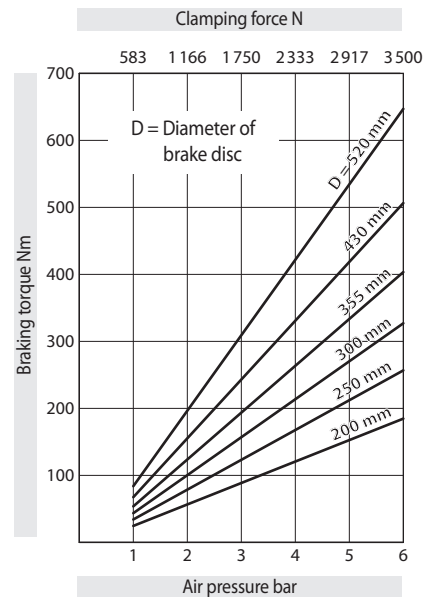

The braking torques shown in the diagram are based on a theoretical friction coefficient of 0,4.

Air pressure: max. 6 bar

Air volume: max. 120 cm<sup>3</sup> per activation

Weight: 4,8 kg

# Brake Caliper DH 020 PFK

pneumatically activated – spring released



63-1

## Features

Features	Code
Brake Caliper	D
Mounting to the machine at right angles to the brake disc	H
Frame size 020	020
Pneumatically activated	P
Spring released	F
No adjustment to accommodate friction block wear	K
Thruster 630	630
Thruster mounted in central position	M
Thickness of brake disc 12,5 mm	12

## Example for ordering

Brake Caliper DH 020 PFK, thruster 630, thruster mounted in central position, thickness of brake disc 12,5 mm:

DH 020 PFK - 630 M - 12

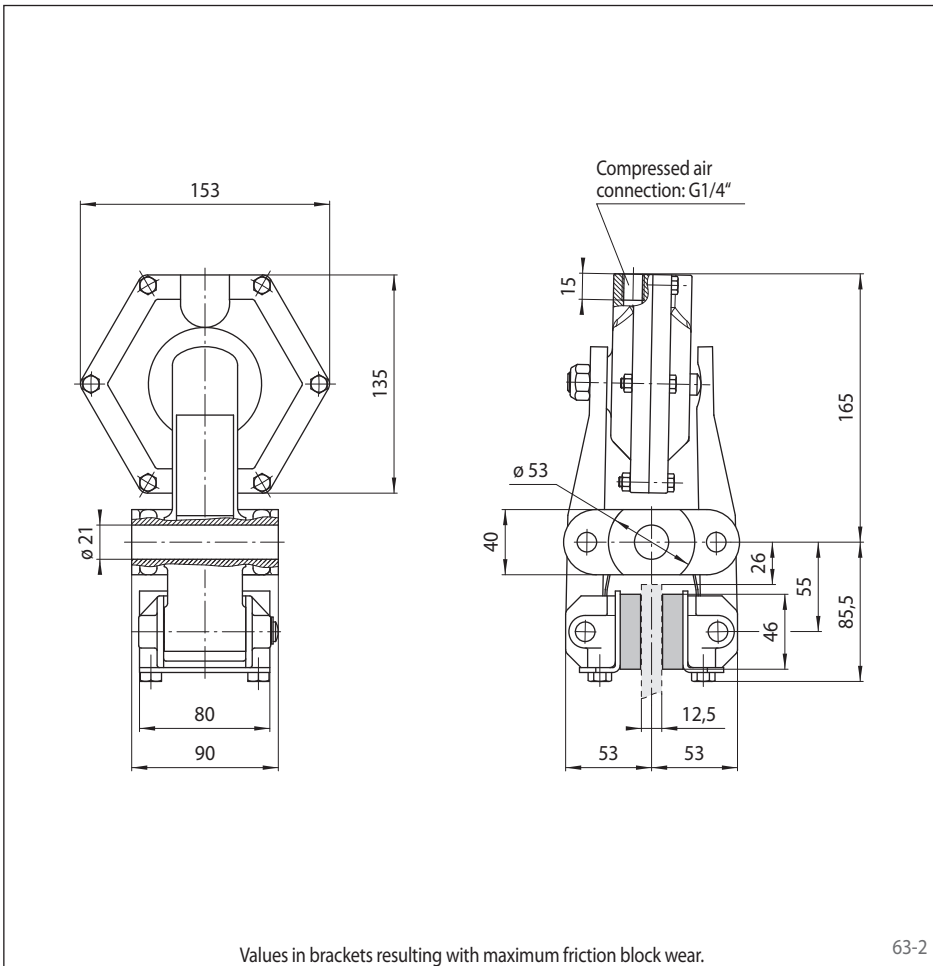

Values in brackets resulting with maximum friction block wear.

63-2

## Technical Data

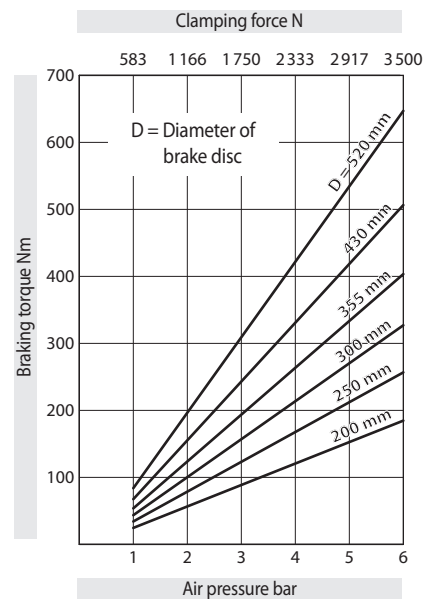

The braking torques shown in the diagram are based on a theoretical friction coefficient of 0,4.

Air pressure: max. 6 bar

Air volume: max. 120 cm<sup>3</sup> per activation

Weight: 4,8 kg

# Brake Caliper DH 025 PFM

pneumatically activated – spring released

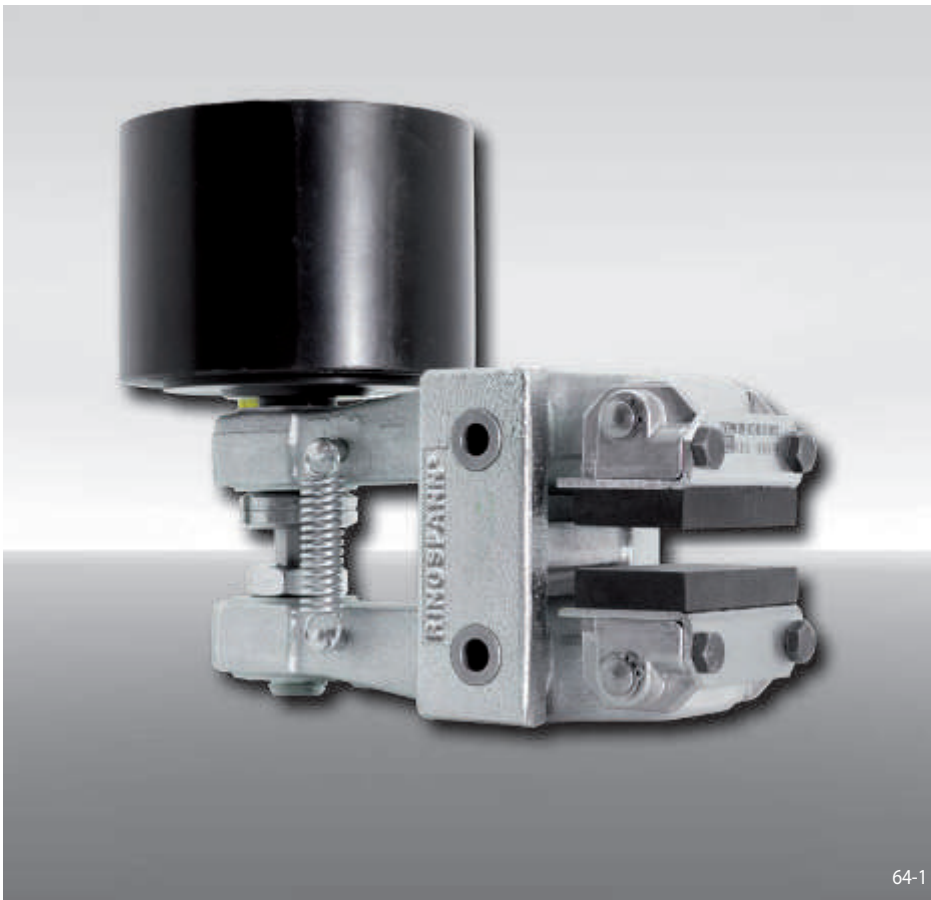

## Features

Features	Code
Brake Caliper	D
Mounting to the machine at right angles to the brake disc	H
Frame size 025	025
Pneumatically activated	P
Spring released	F
Manual adjustment to accommodate friction block wear	M
Thrusters 635 or 655 are available	635 655
Thruster mounted right or left available	R L
Thickness of brake disc 12,5 mm or 25 mm	12 25

## Example for ordering

Brake Caliper DH 025 PFM, thruster 635, thruster mounted right, thickness of brake disc 12,5 mm:

DH 025 PFM - 635 R - 12

## Technical Data

Brake Caliper DH 025 PFM - 635

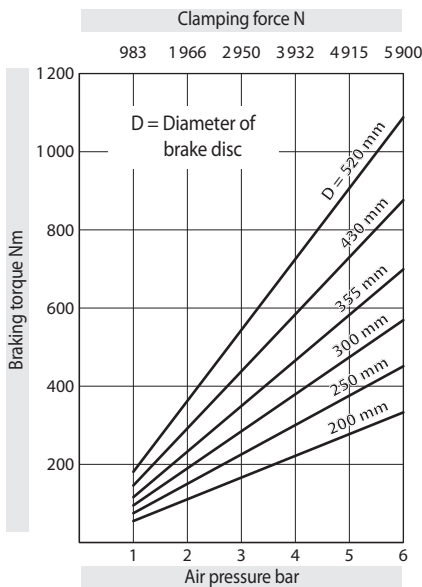

The braking torques shown in the diagram are based on a theoretical friction coefficient of 0,4.

Air pressure: max. 6 bar

Air volume: max. 175 cm<sup>3</sup> per activation

Weight: 7,1 kg

Brake Caliper DH 025 PFM - 655

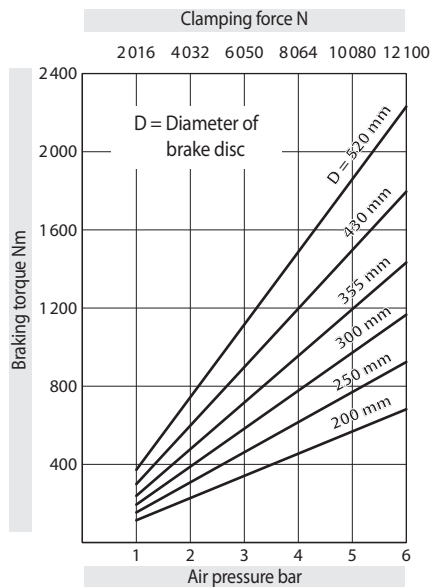

The braking torques shown in the diagram are based on a theoretical friction coefficient of 0,4.

Air pressure: max. 6 bar

Air volume: max. 740 cm<sup>3</sup> per activation

Weight: 10,3 kg

# Brake Caliper DH 025 PFM

pneumatically activated – spring released

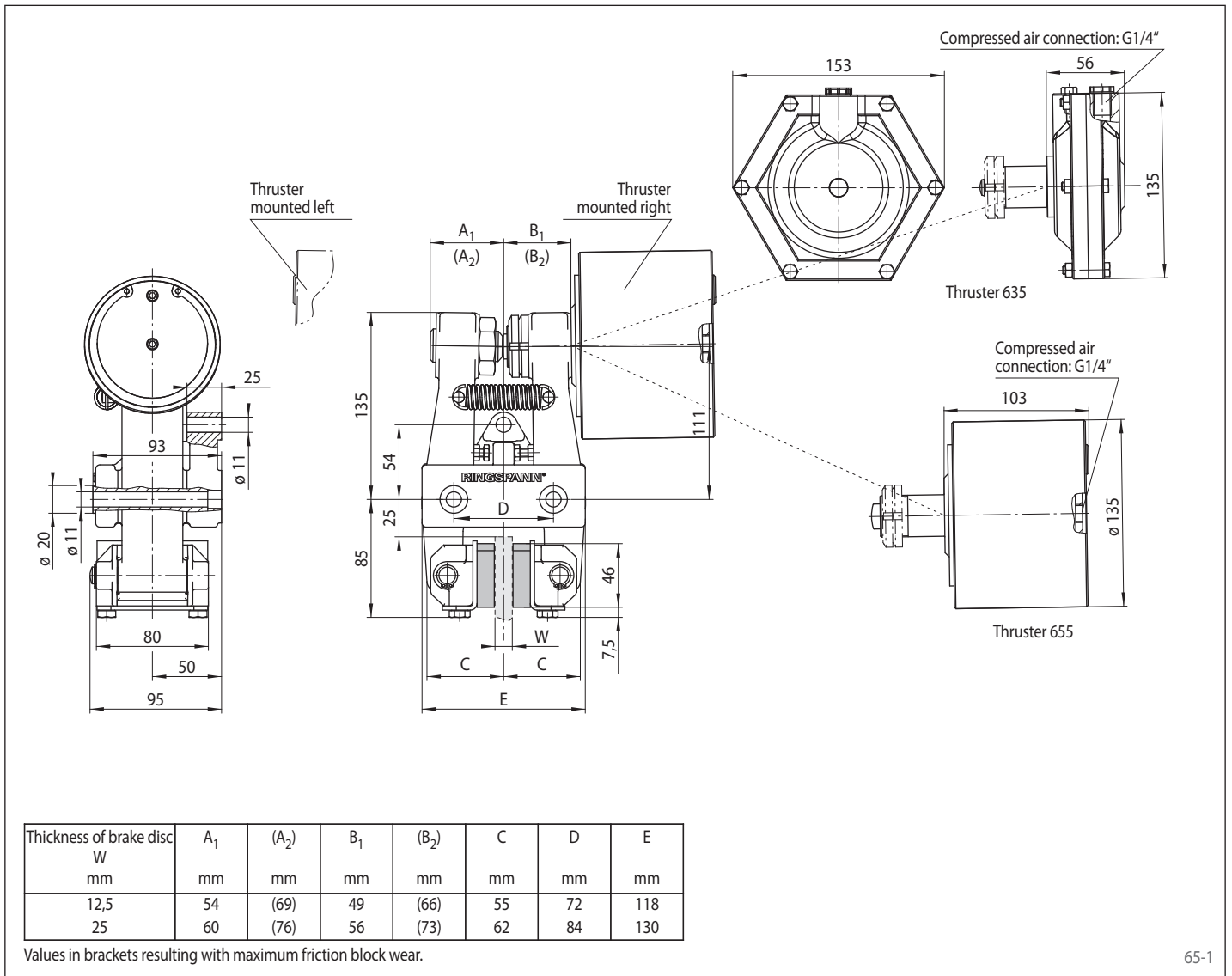

# Brake Caliper DV 030 PFM

pneumatically activated – spring released

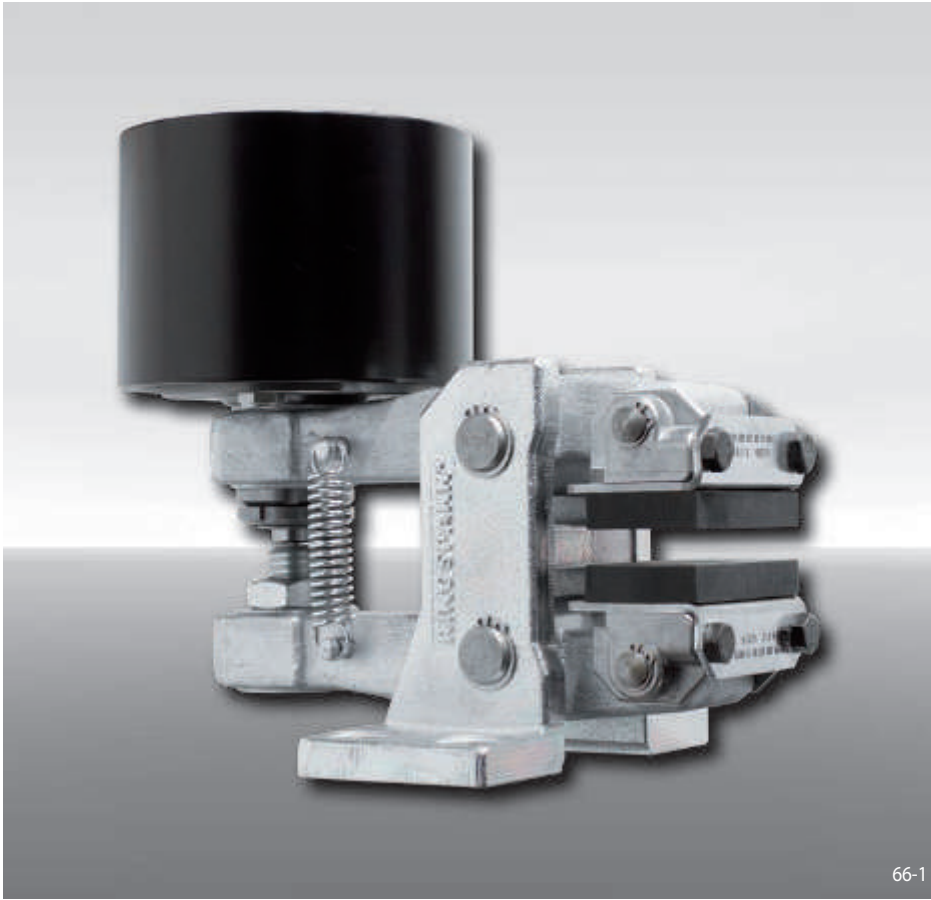

## Features

Features	Code
Brake Caliper	D
Mounting to the machine parallel to the brake disc	V
Frame size 030	030
Pneumatically activated	P
Spring released	F
Manual adjustment to accommodate friction block wear	M
Thrusters 635 or 655 are available	635 655
Thruster mounted right or left available	R L
Thickness of brake disc 12,5 mm or 25 mm	12 25

## Example for ordering

Brake Caliper DV 030 PFM, thruster 635, thruster mounted right, thickness of brake disc 12,5 mm:

DV 030 PFM - 635 R - 12

## Technical Data

Brake Caliper DV 030 PFM - 635

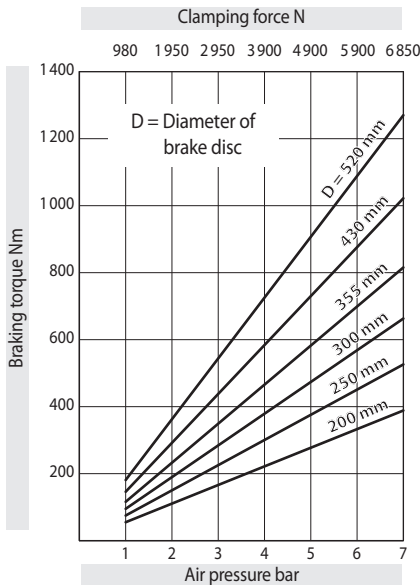

The braking torques shown in the diagram are based on a theoretical friction coefficient of 0,4.

Air pressure: max. 7 bar

Air volume: max. 175 cm<sup>3</sup> per activation

Weight: 7,3 kg

Brake Caliper DV 030 PFM - 655

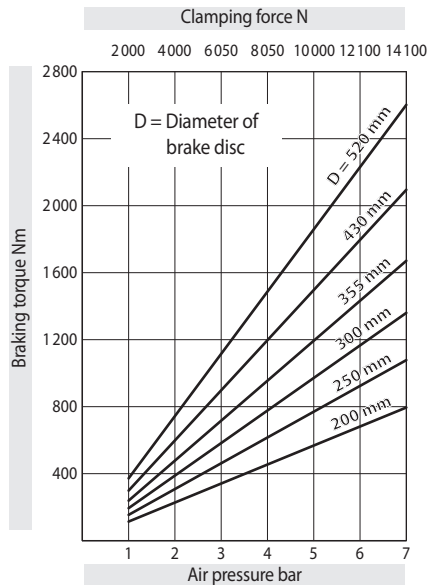

The braking torques shown in the diagram are based on a theoretical friction coefficient of 0,4.

Air pressure: max. 7 bar

Air volume: max. 740 cm<sup>3</sup> per activation

Weight: 10,5 kg

# Brake Caliper DV 030 PFM

pneumatically activated – spring released

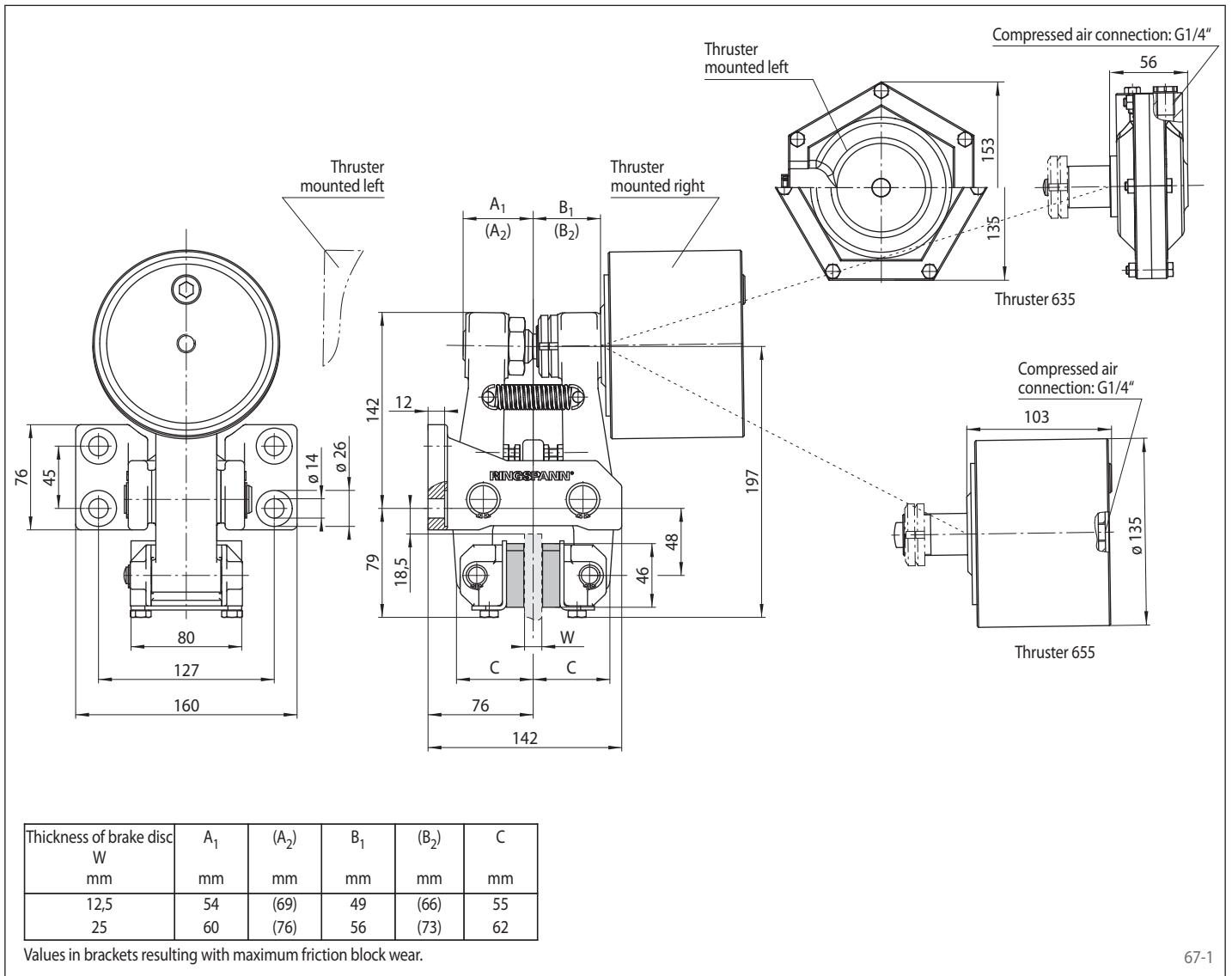



# Brake Caliper DH 030 PFM

pneumatically activated – spring released

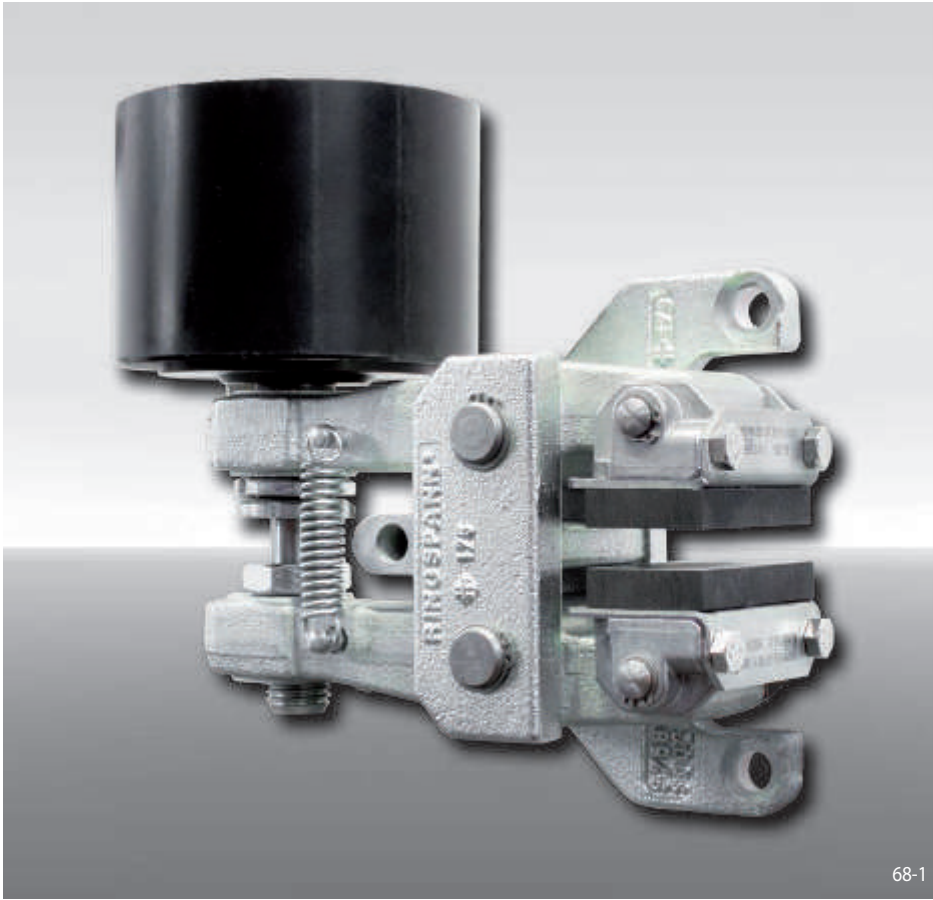

## Features

Features	Code
Brake Caliper	D
Mounting to the machine at right angles to the brake disc	H
Frame size 030	030
Pneumatically activated	P
Spring released	F
Manual adjustment to accommodate friction block wear	M
Thrusters 635 or 655 are available	635 655
Thruster mounted right or left available	R L
Thickness of brake disc 12,5 mm or 25 mm	12 25

## Example for ordering

Brake Caliper DH 030 PFM, thruster 635, thruster mounted right, thickness of brake disc 12,5 mm:

DH 030 PFM - 635 R - 12

## Technical Data

### Brake Caliper DH 030 PFM - 635

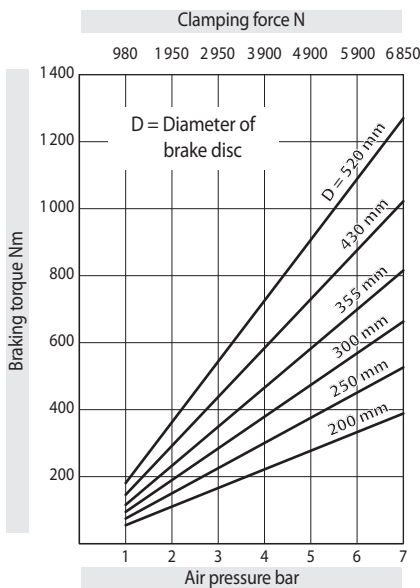

The braking torques shown in the diagram are based on a theoretical friction coefficient of 0,4.

Air pressure: max. 7 bar

Air volume: max. 175 cm<sup>3</sup> per activation

Weight: 7,7 kg

### Brake Caliper DH 030 PFM - 655

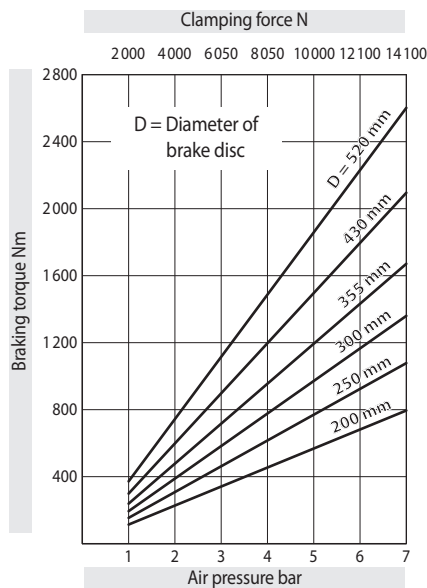

The braking torques shown in the diagram are based on a theoretical friction coefficient of 0,4.

Air pressure: max. 7 bar

Air volume: max. 740 cm<sup>3</sup> per activation

Weight: 10,9 kg

# Brake Caliper DH 030 PFM

pneumatically activated – spring released

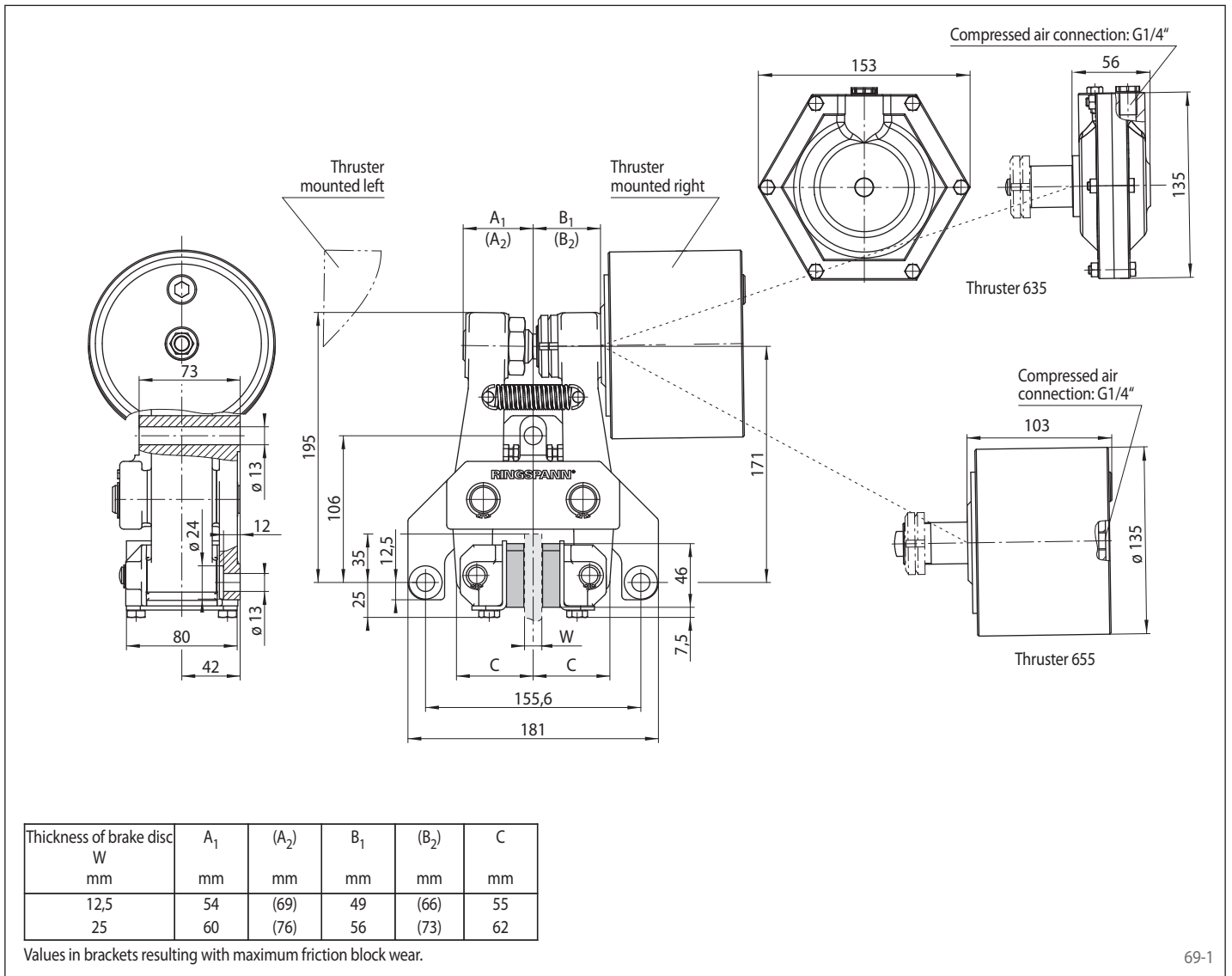

# Brake Caliper DV 035 PFM

pneumatically activated – spring released

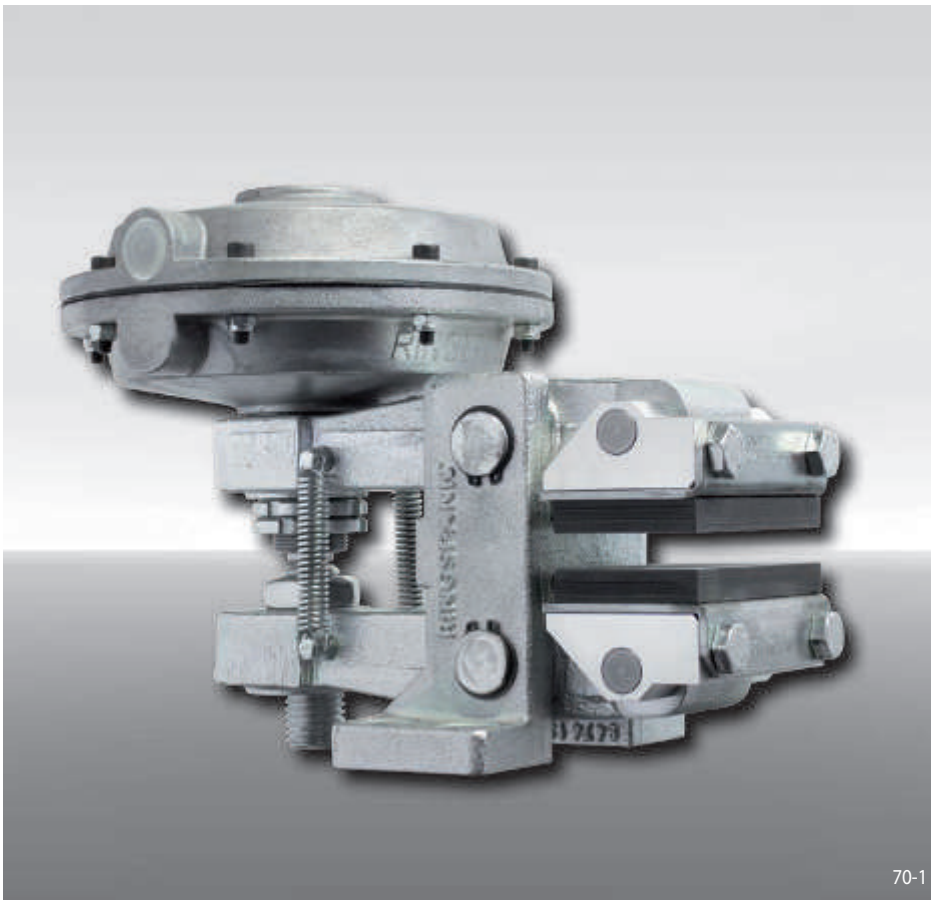

## Features

Features	Code
Brake Caliper	D
Mounting to the machine parallel to the brake disc	V
Frame size 035	035
Pneumatically activated	P
Spring released	F
Manual adjustment to accommodate friction block wear	M
Thrusters 635, 655 or 660 are available	635 655 660
Thruster mounted right available	R
Thickness of brake disc 12,5 mm, 25 mm, 30 mm or 40 mm	12 to 40

## Example for ordering

Brake Caliper DV 035 PFM, thruster 660, thruster mounted right, thickness of brake disc 12,5 mm:

DV 035 PFM - 660 R - 12

## Technical Data

Brake Caliper DV 035 PFM - 635

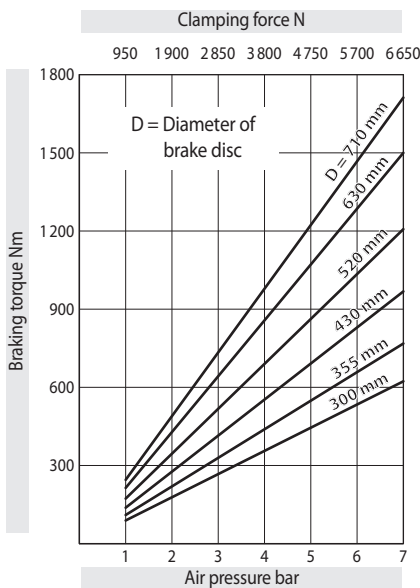

The braking torques shown in the diagram are based on a theoretical friction coefficient of 0,4.

Air pressure: max. 7 bar

Air volume: max. 175 cm<sup>3</sup> per activation

Weight: 9,1 kg

Brake Caliper DV 035 PFM - 655

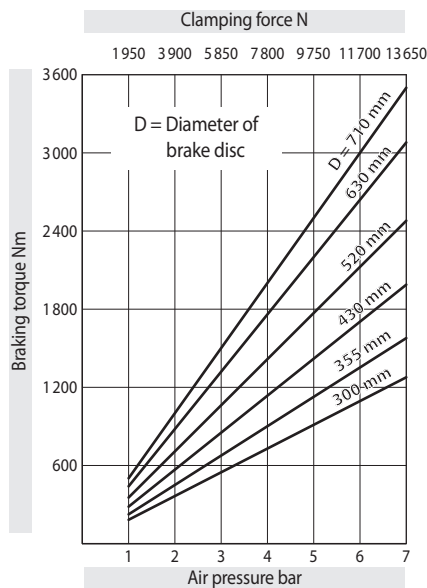

The braking torques shown in the diagram are based on a theoretical friction coefficient of 0,4.

Air pressure: max. 7 bar

Air volume: max. 740 cm<sup>3</sup> per activation

Weight: 12,3 kg

Brake Caliper DV 035 PFM - 660

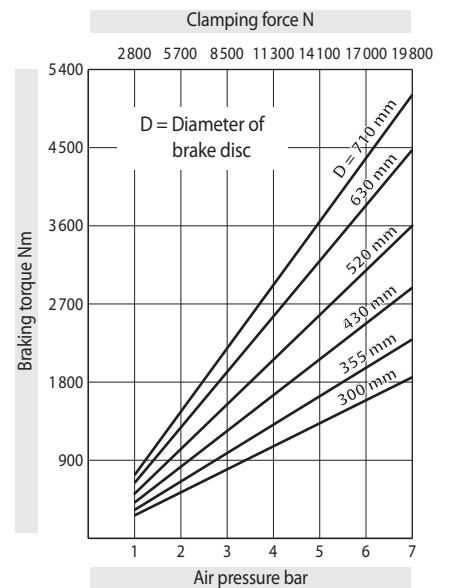

The braking torques shown in the diagram are based on a theoretical friction coefficient of 0,4.

Air pressure: max. 7 bar

Air volume: max. 450 cm<sup>3</sup> per activation

Weight: 11,4 kg

# Brake Caliper DV 035 PFM

pneumatically activated – spring released

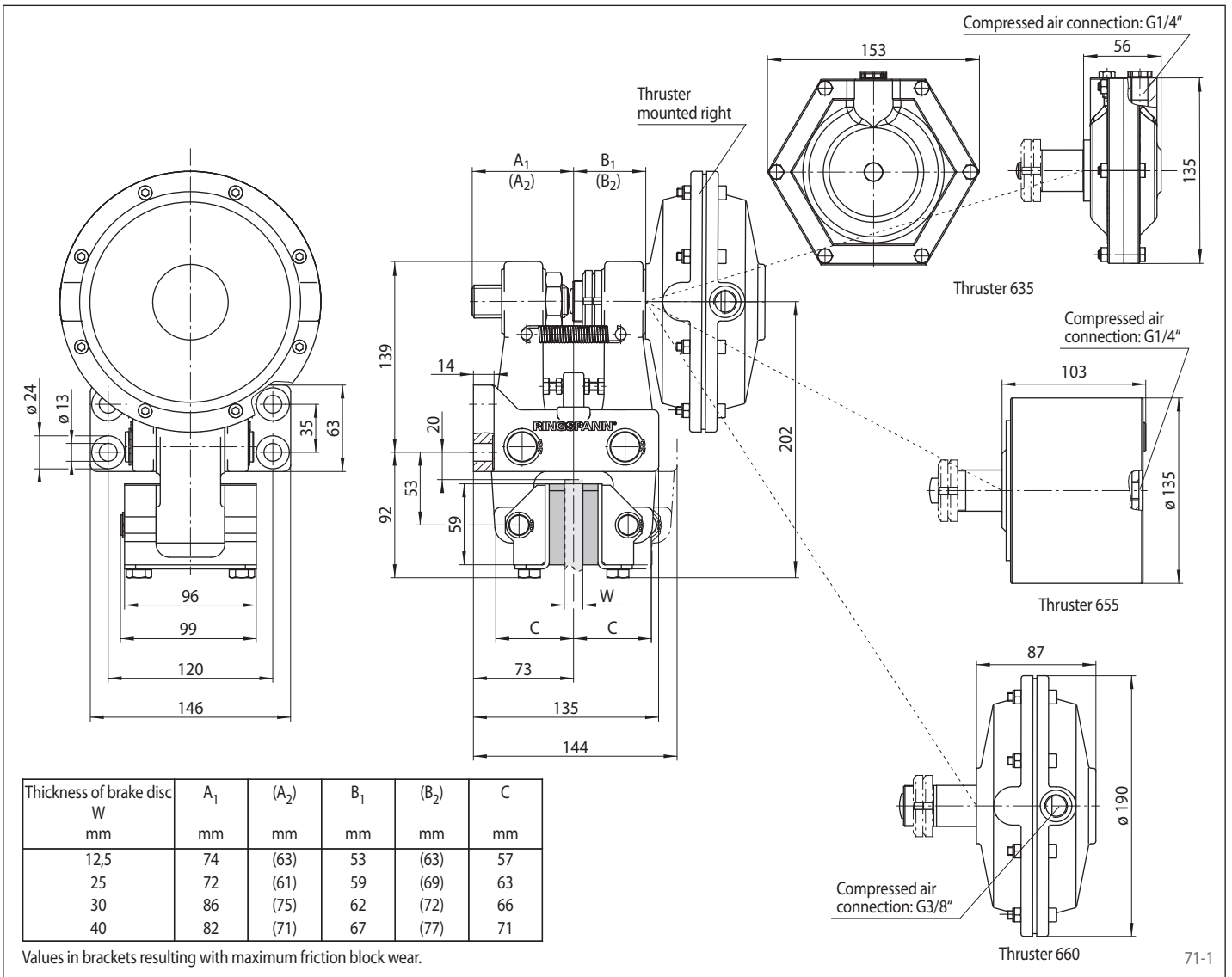

# Brake Caliper DH 035 PFM

pneumatically activated – spring released

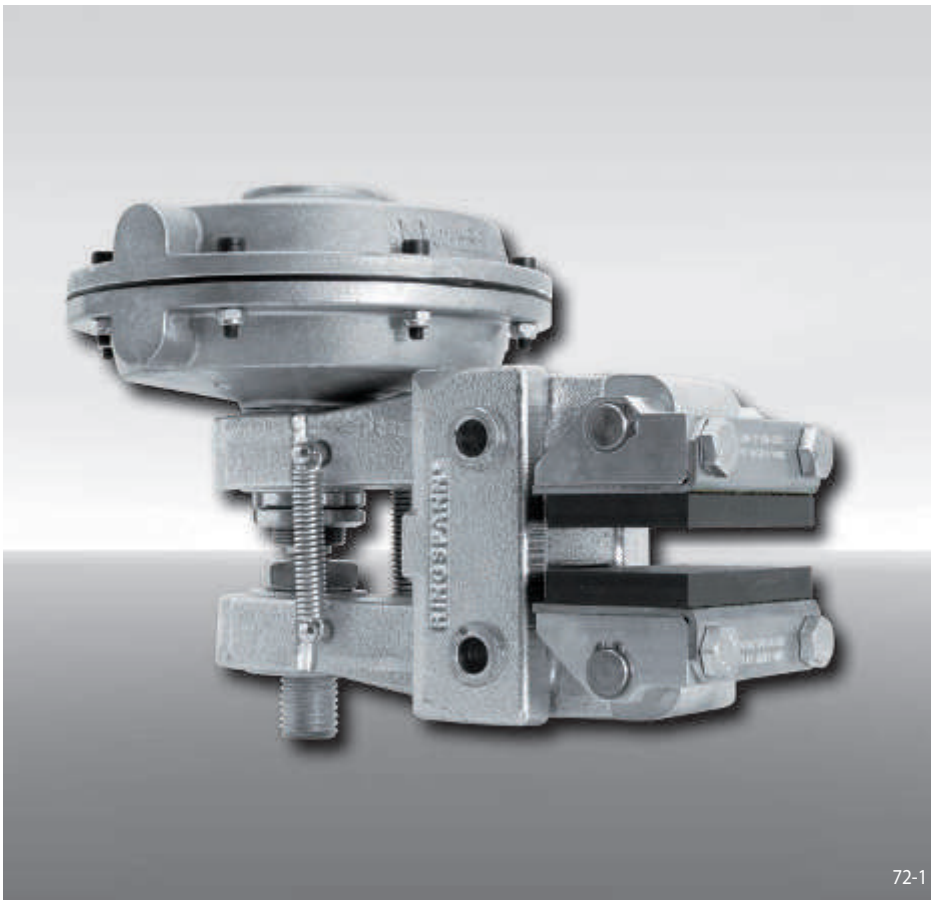

72-1

## Features

Features	Code
Brake Caliper	D
Mounting to the machine at right angles to the brake disc	H
Frame size 035	035
Pneumatically activated	P
Spring released	F
Manual adjustment to accommodate friction block wear	M
Thrusters 635, 655 or 660 are available	635 655 660
Thruster mounted right or left available	R L
Thickness of brake disc 12,5 mm, 25 mm, 30 mm or 40 mm	12 to 40

## Example for ordering

Brake Caliper DH 035 PFM, thruster 660, thruster mounted right, thickness of brake disc 12,5 mm:

DH 035 PFM - 660 R - 12

## Technical Data

Brake Caliper DH 035 PFM - 635

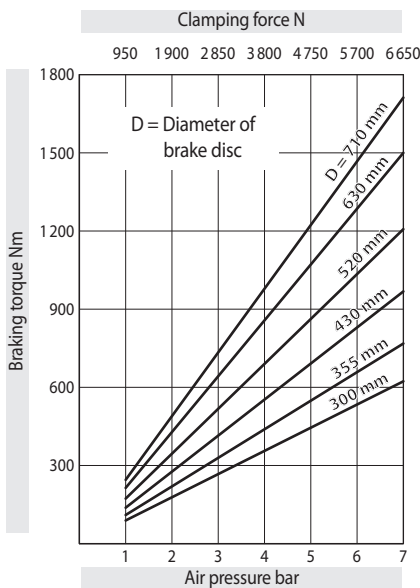

The braking torques shown in the diagram are based on a theoretical friction coefficient of 0,4.

Air pressure: max. 7 bar

Air volume: max. 175 cm<sup>3</sup> per activation

Weight: 9,1 kg

Brake Caliper DH 035 PFM - 655

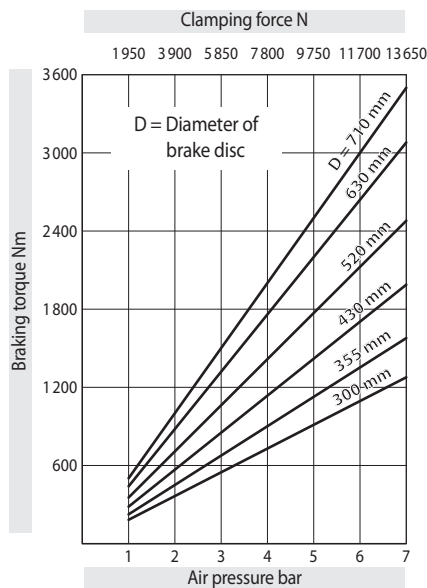

The braking torques shown in the diagram are based on a theoretical friction coefficient of 0,4.

Air pressure: max. 7 bar

Air volume: max. 740 cm<sup>3</sup> per activation

Weight: 12,3 kg

Brake Caliper DH 035 PFM - 660

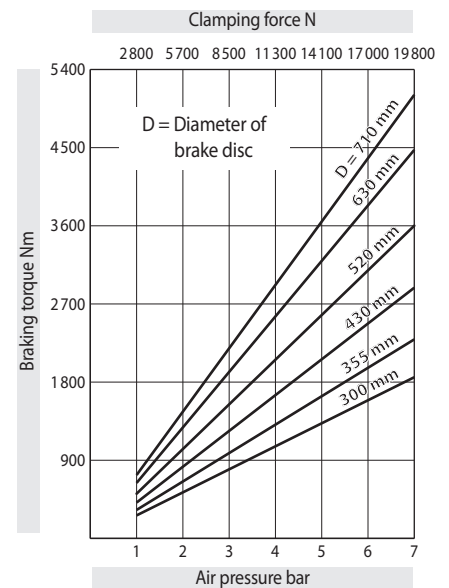

The braking torques shown in the diagram are based on a theoretical friction coefficient of 0,4.

Air pressure: max. 7 bar

Air volume: max. 450 cm<sup>3</sup> per activation

Weight: 11,4 kg

# Brake Caliper DH 035 PFM

pneumatically activated – spring released

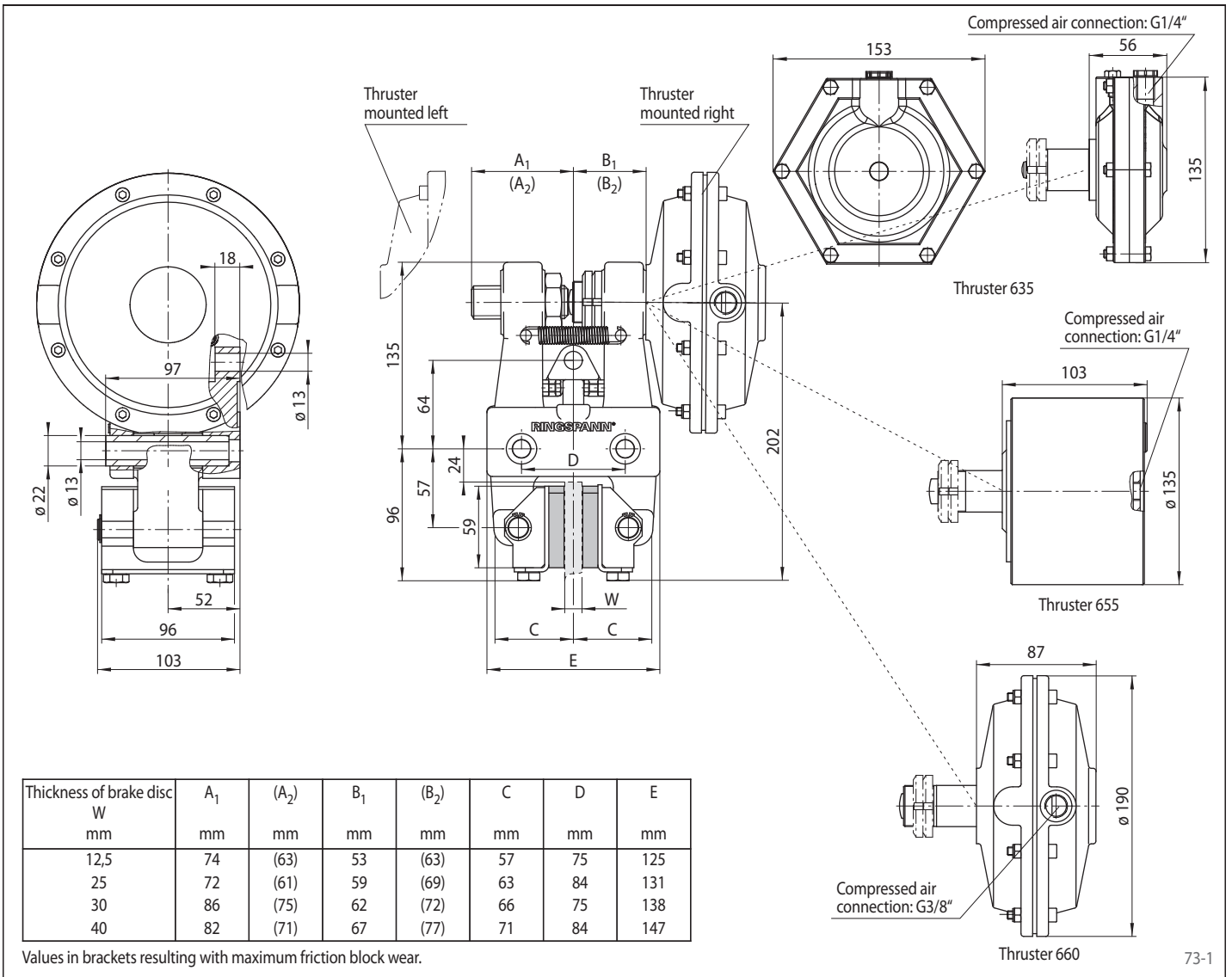



# Brake Caliper DU 060 PFM

pneumatically activated – spring released



## Features

Features	Code
Brake Caliper	D
Mounting to the machine, can be made either parallel or at the right angles to the brake disc	U
Frame size 060	060
Pneumatically activated	P
Spring released	F
Manual adjustment to accommodate friction block wear	M
Thrusters 660 or 680 are available	660 680
Thruster mounted right or left available	R L
Thickness of brake disc 25 mm or 40 mm	25 40

## Example for ordering

Brake Caliper DU 060 PFM, thruster 680, thruster mounted right, thickness of brake disc 25 mm:

DU 060 PFM - 680 R - 25

## Technical Data

Brake Caliper DU 060 PFM - 660

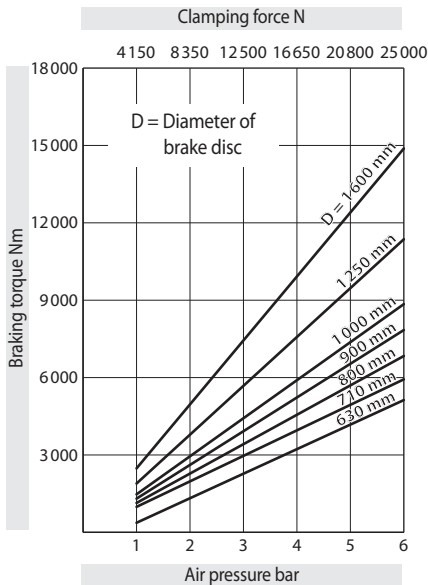

The braking torques shown in the diagram are based on a theoretical friction coefficient of 0,4.

Air pressure: max. 6 bar

Air volume: max. 450 cm<sup>3</sup> per activation

Weight: 54 kg

Brake Caliper DU 060 PFM - 680

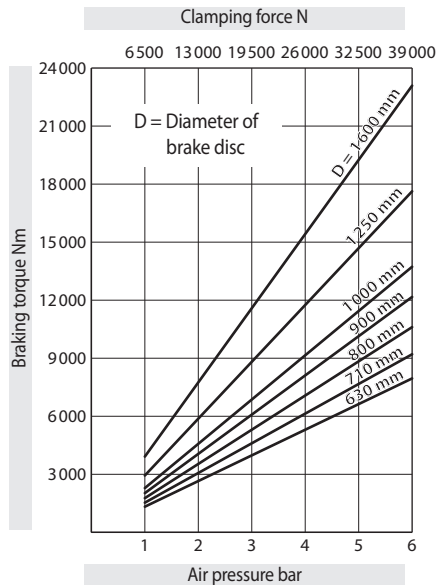

The braking torques shown in the diagram are based on a theoretical friction coefficient of 0,4.

Air pressure: max. 6 bar

Air volume: max. 2.000 cm<sup>3</sup> per activation

Weight: 56 kg

# Brake Caliper DU 060 PFM

pneumatically activated – spring released

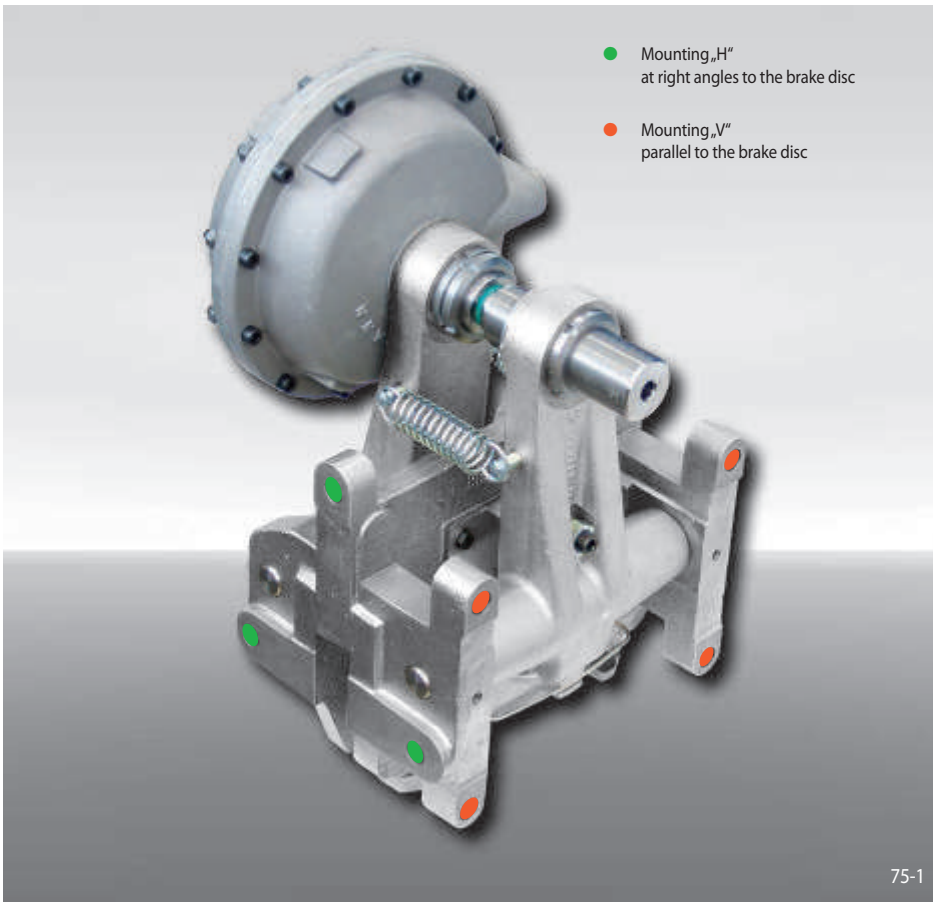

- Mounting „H“ at right angles to the brake disc
- Mounting „V“ parallel to the brake disc

## Frame Design

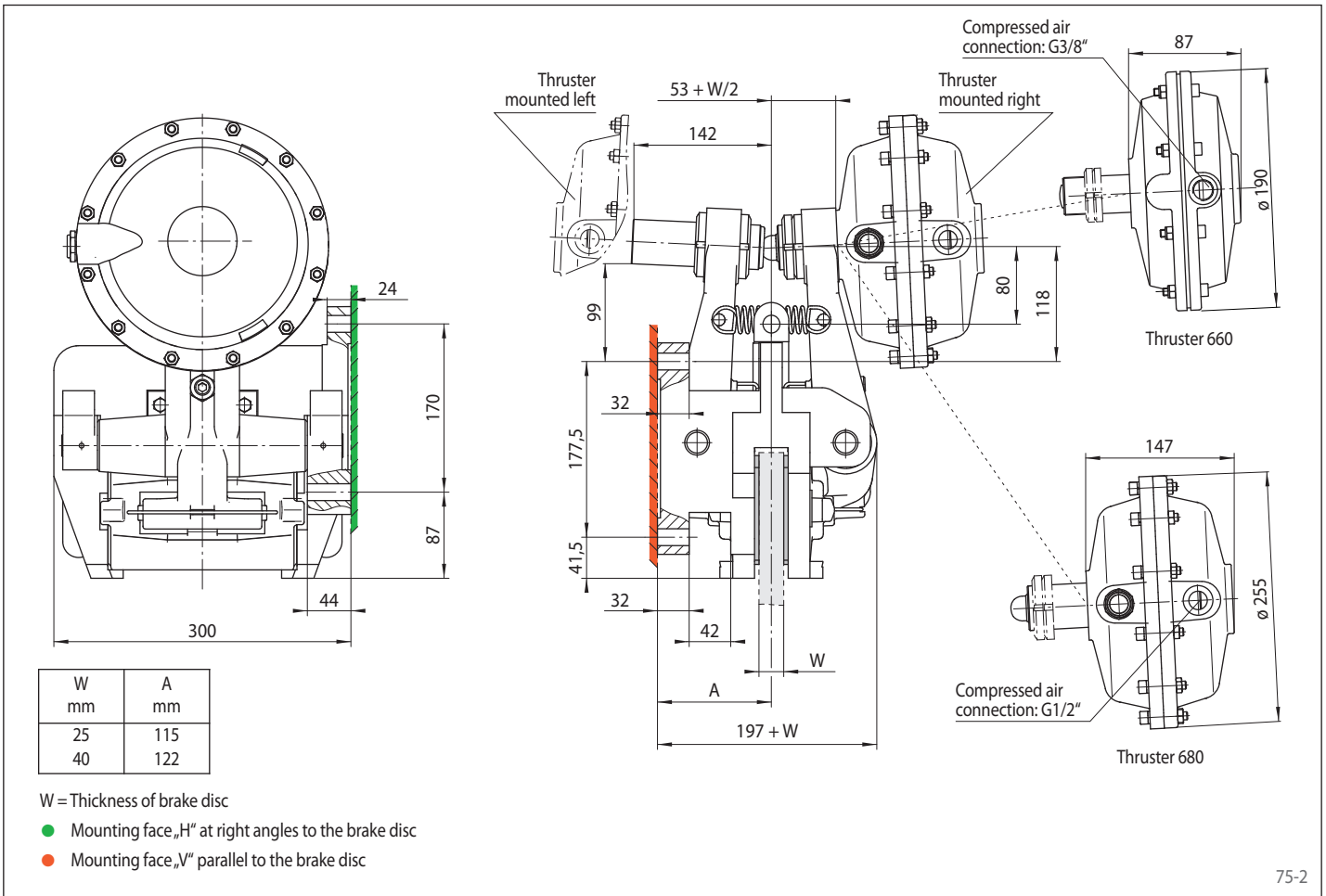
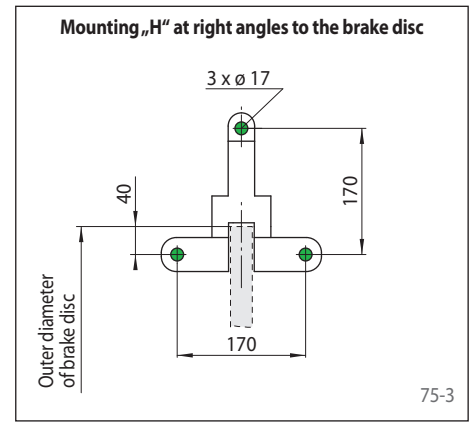
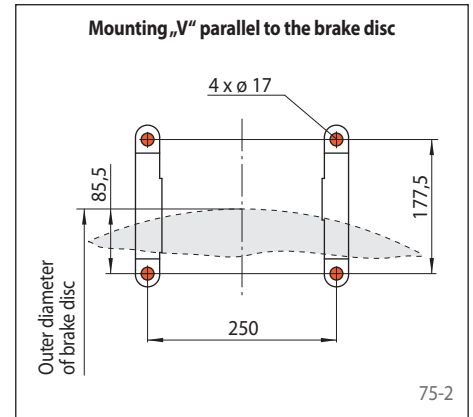

W mm	A mm
25	115
40	122

W = Thickness of brake disc

- Mounting face „H“ at right angles to the brake disc
- Mounting face „V“ parallel to the brake disc

# Brake Calipers EV 018 EFM and EH 018 EFM

electromagnetically activated – spring released

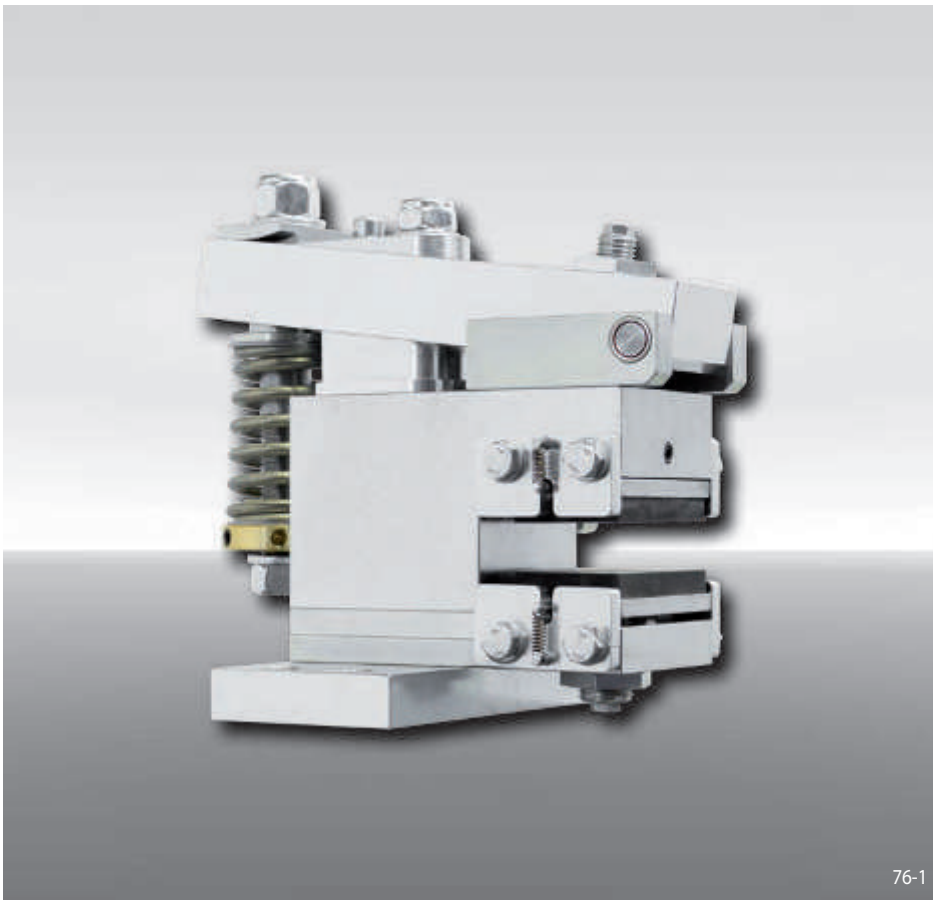

76-1

## Features

Features	Code
Brake Caliper with electromagnet	E
Mounting to the machine parallel or at right angles to the brake disc	V H
Frame size 018	018
Electromagnetically activated	E
Spring released	F
Manual adjustment to accommodate friction block wear	M
Supply voltage 230 to 415 VAC, supply frequency 50 Hz or 60 Hz adjustable	400
Electromagnet mounted in central position	M
Thickness of brake disc 8 ... 15 mm or 16 ... 20 mm	12 20

## Example for ordering

Brake Caliper EV 018 EFM, supply voltage 400 VAC, electromagnet mounted in central position, thickness of brake disc 15 mm:

EV 018 EFM - 400 M - 12

## Advantages

The brake caliper EV 018 EFM or EH 018 EFM is a very compact and high efficient disc brake with very low power consumption. Its floating bearing compensates small misalignments of the brake disc. The separate electronic module (included) reduces automatically the power consumption in closed position to 10 W.

## Options

- Inductive proximity switch: "Brake released"-, "Brake closed"-status and/or "Friction block wear adjustment necessary"

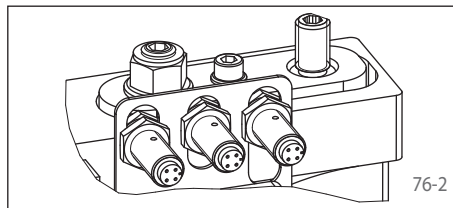

76-2

## Electronic module

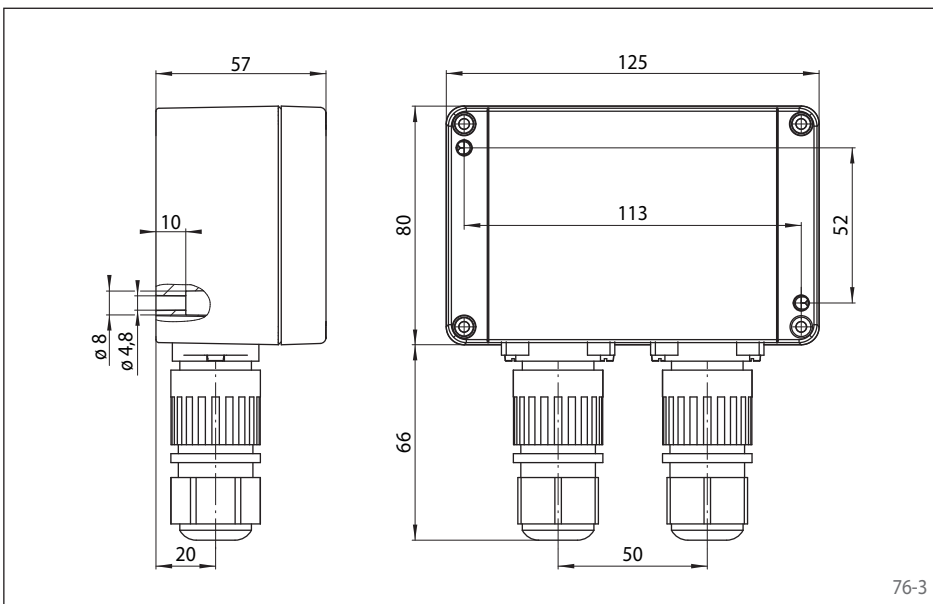

76-3

## Technical Data

	Brake Calipers EV 018 EFM and EH 018 EFM with supply voltage	
	230/240 VAC	380/400/415 VAC
Brake disc diameter	Braking torque	Braking torque
mm	Nm	Nm
125	60	95
150	75	125
200	110	185
250	150	245
300	180	305
355	220	370
Clamping force	1800 N	3000 N
Clamping force or braking torque adjustable	70 - 100%	50 - 100%
Power consumption in closed position	10 W (100% duty factor)	
Fuse rating	16A, time-lag	
Switching frequency	240/h permanent activations at 20° C ambient temperature	
Switching time*	at least 10 seconds	
Weight	6,5 kg	

The braking torques shown in the table are based on a theoretical friction coefficient of 0,4.

\* shorter switching time on request

# Brake Calipers EV 018 EFM and EH 018 EFM

electromagnetically activated – spring released

## Brake Caliper EV 018 EFM

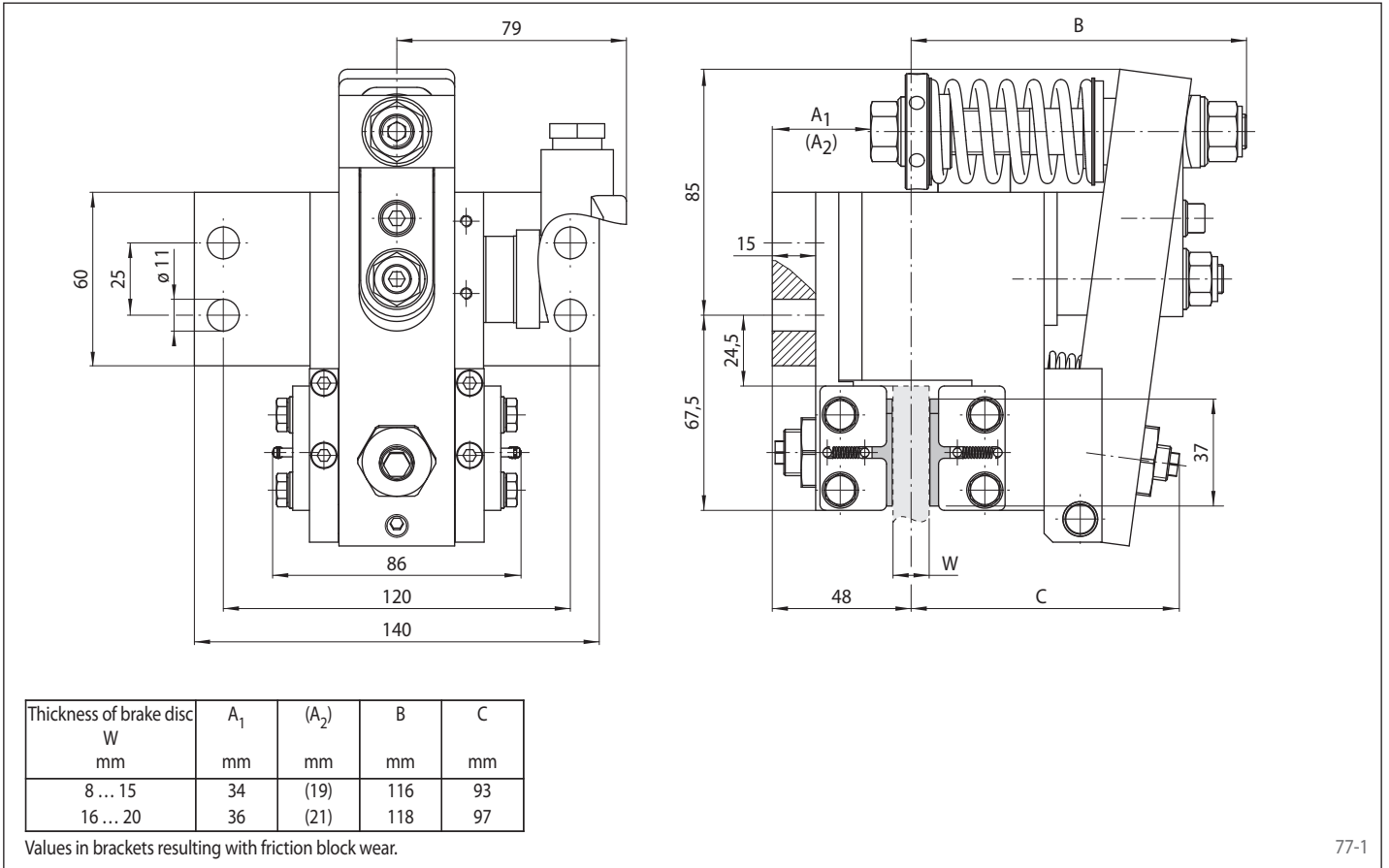

77-1

## Brake Caliper EH 018 EFM

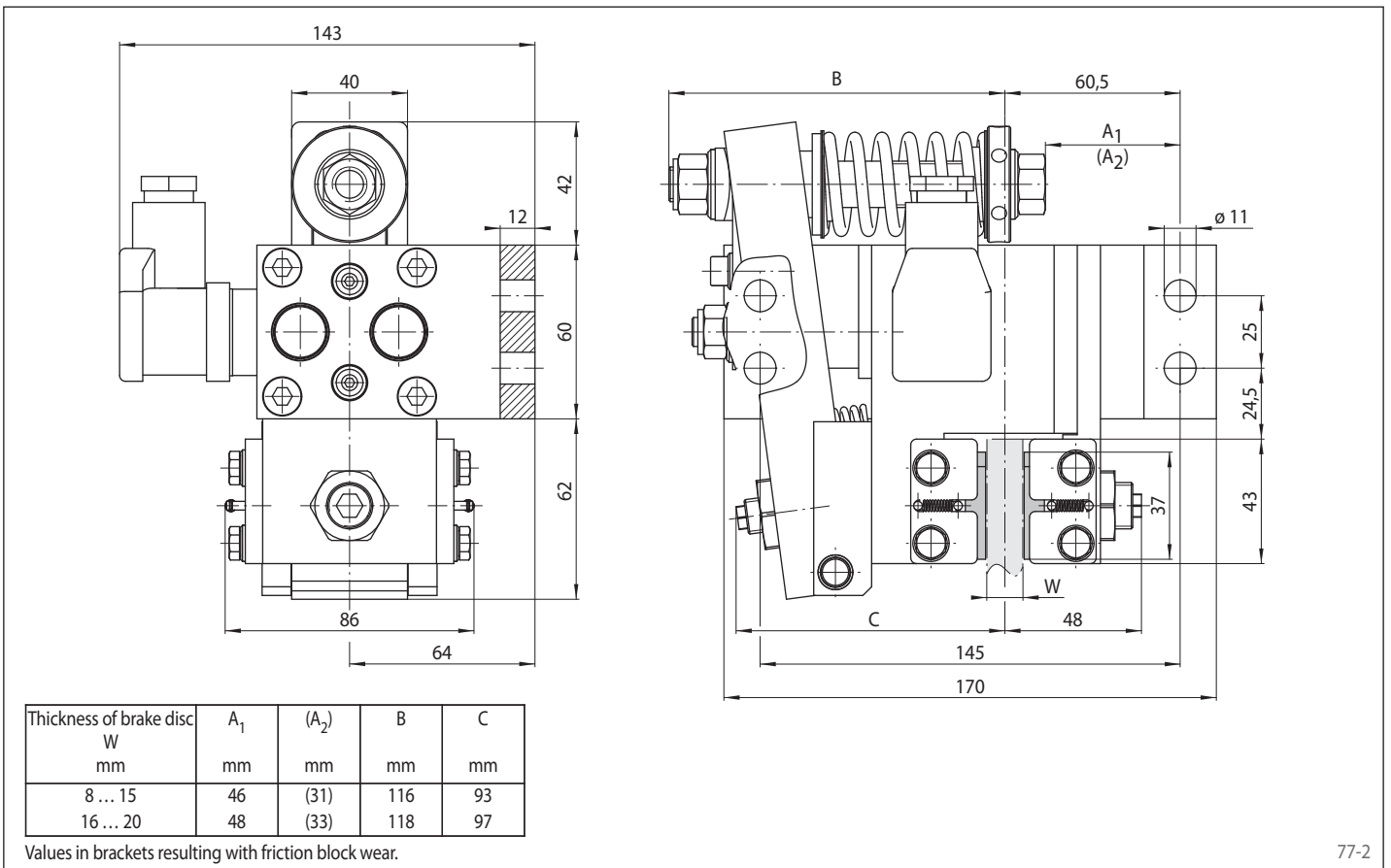

77-2

# Brake Calipers EV 024 EFM and EH 024 EFM

electromagnetically activated – spring released

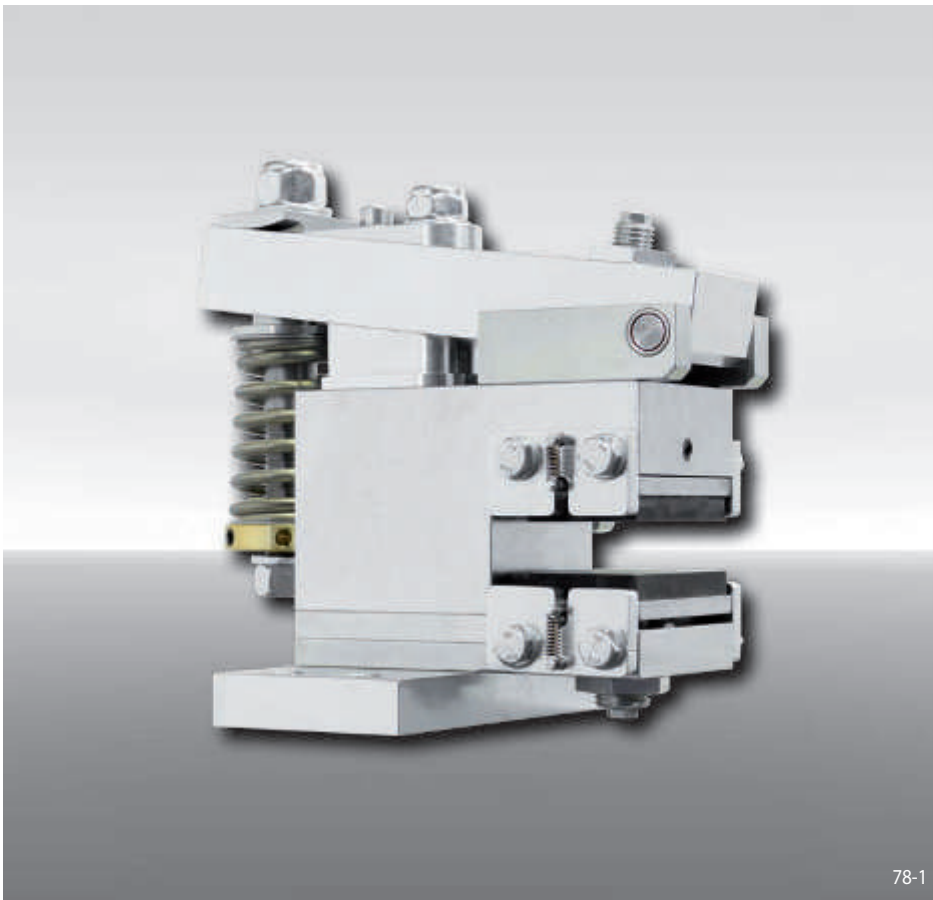

78-1

## Features

Features	Code
Brake Caliper with electromagnet	E
Mounting to the machine parallel or at right angles to the brake disc	V H
Frame size 024	024
Electromagnetically activated	E
Spring released	F
Manual adjustment to accommodate friction block wear	M
Supply voltage 230 to 415 VAC, supply frequency 50 Hz or 60 Hz adjustable	400
Electromagnet mounted in central position	M
Thickness of brake disc 10 ... 16 mm or 18 ... 26 mm	12 25

## Example for ordering

Brake Caliper EV 024 EFM, supply voltage 400 VAC, electromagnet mounted in central position, thickness of brake disc 15 mm:

EV 024 EFM - 400 M - 12

## Advantages

The brake caliper EV 024 EFM or EH 024 EFM is a very compact and high efficient disc brake with very low power consumption. Its floating bearing compensates small misalignments of the brake disc. The attached electronic reduces automatically the power consumption in closed position to 10 W.

## Options

- Inductive proximity switch: "Brake released", "Brake closed"-status and/or "Friction block wear adjustment necessary"

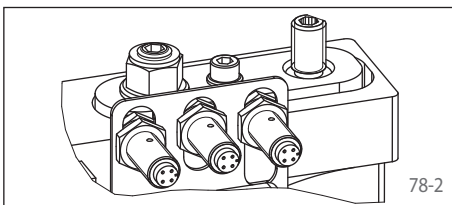

78-2

## Technical Data

	Brake Calipers EV 024 EFM and EH 024 EFM with supply voltage	
	230/240 VAC	380/400/415 VAC
Brake disc diameter	Braking torque	Braking torque
mm	Nm	Nm
250	320	440
300	400	550
355	490	670
430	610	830
520	750	1 030
630	930	1 270
Clamping force	4 000 N	5 500 N
Clamping force or braking torque adjustable	70 - 100%	60 - 100%
Power consumption in closed position	10 W (100% duty factor)	
Fuse rating	16A, time-lag	
Switching frequency	240/h permanent activations at 20° C ambient temperature	
Switching time*	at least 10 seconds	
Weight	13 kg	

The braking torques shown in the table are based on a theoretical friction coefficient of 0,4.

\* shorter switching time on request

# Brake Calipers EV 024 EFM and EH 024 EFM

electromagnetically activated – spring released

## Brake Caliper EV 024 EFM

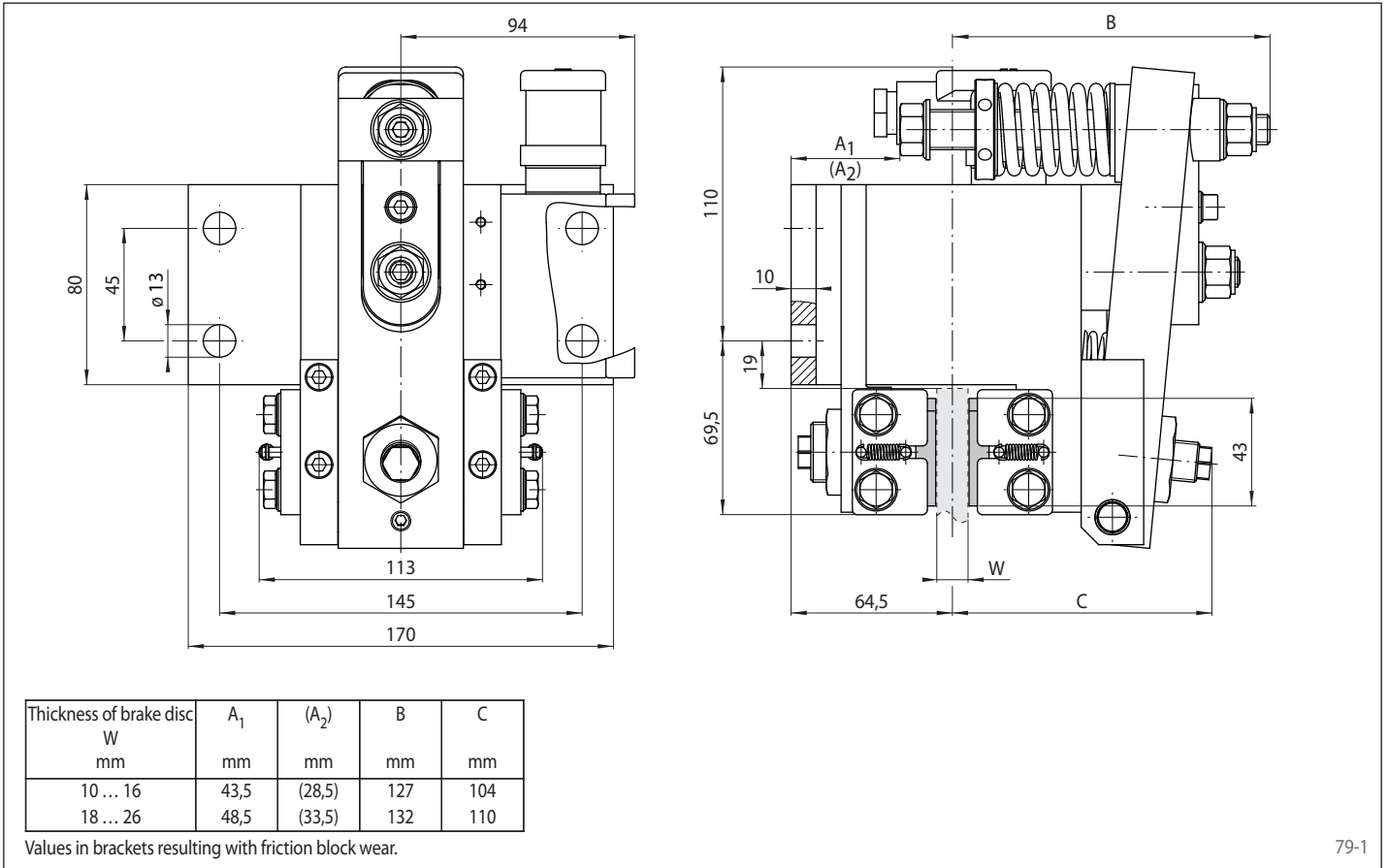

79-1

## Brake Caliper EH 024 EFM

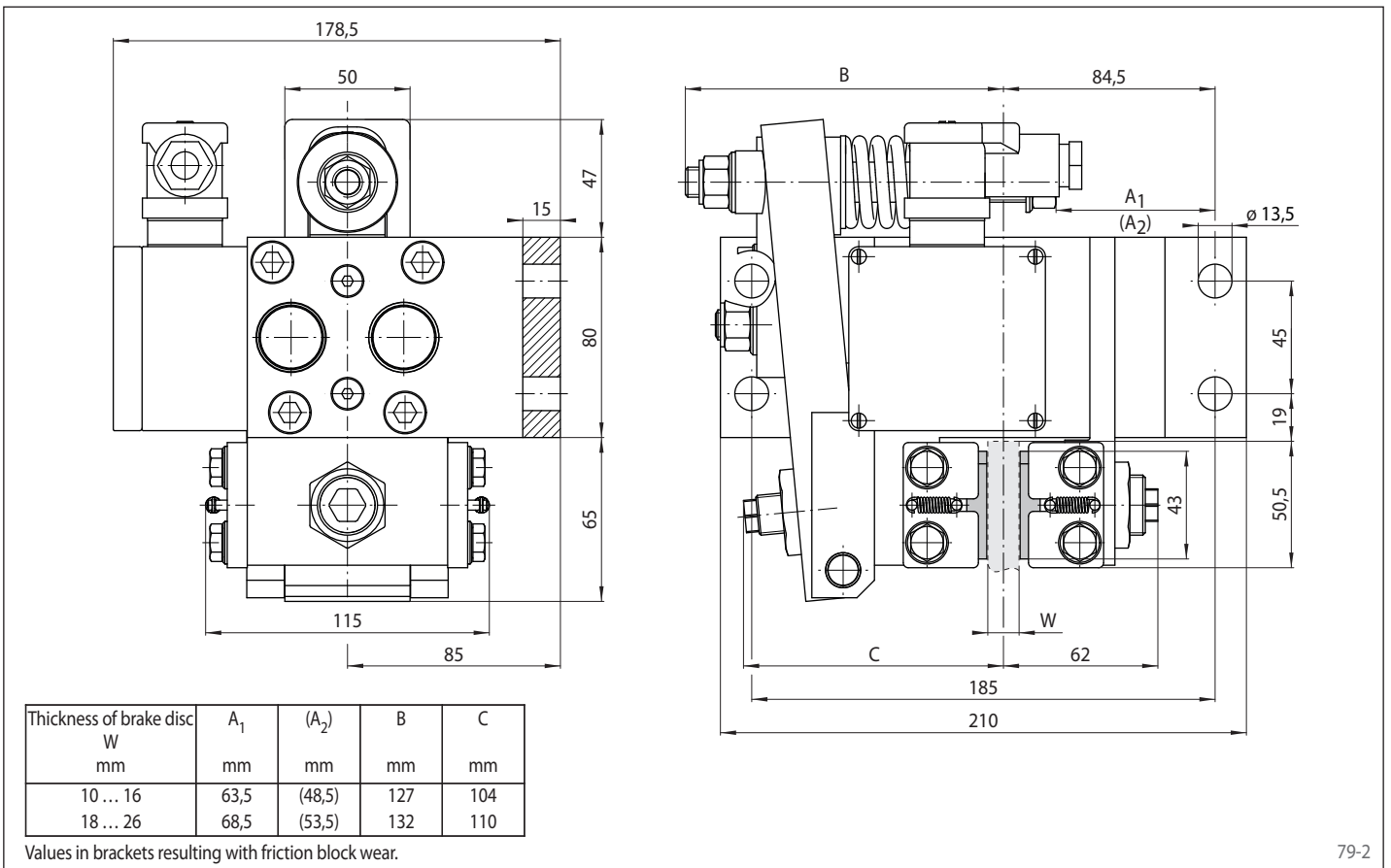

79-2



# Brake Calipers EV 028 EFM and EH 028 EFM

electromagnetically activated – spring released

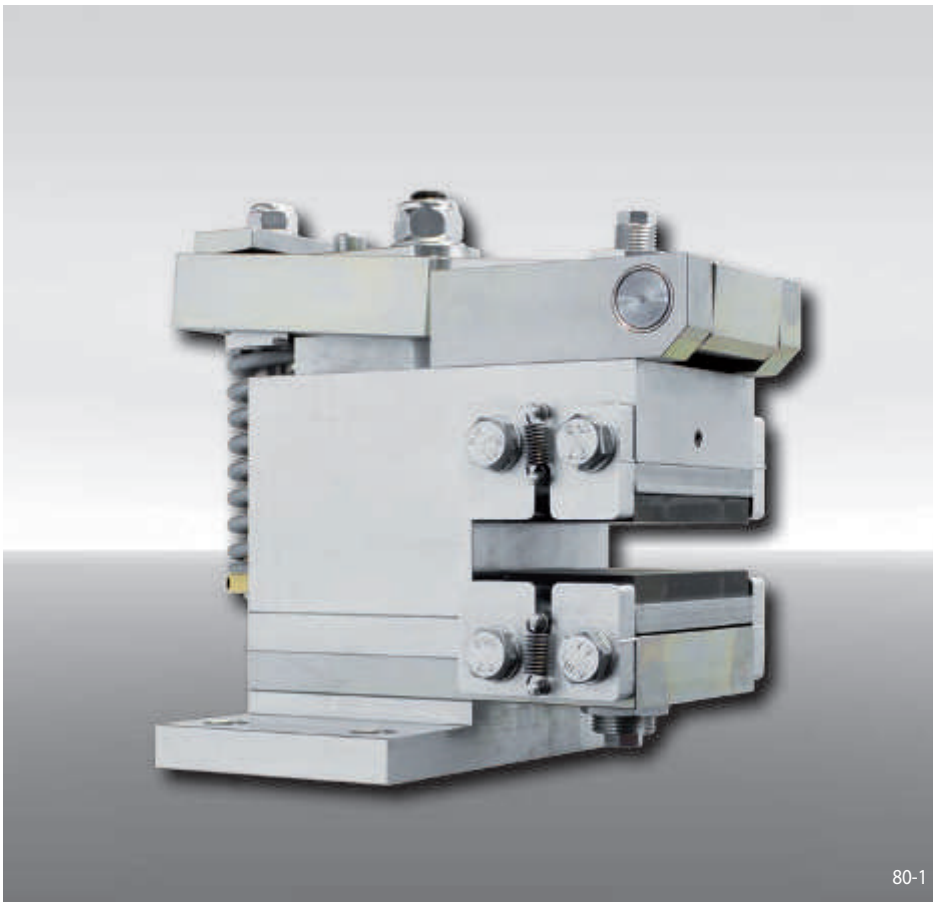

80-1

## Features

Features	Code
Brake Caliper with electromagnet	E
Mounting to the machine parallel or at right angles to the brake disc	V H
Frame size 028	028
Electromagnetically activated	E
Spring released	F
Manual adjustment to accommodate friction block wear	M
Supply voltage 230 to 415 VAC, supply frequency 50 Hz or 60 Hz adjustable	400
Electromagnet mounted in central position	M
Thickness of brake disc 10 ... 16 mm or 18 ... 26 mm	12 25

## Example for ordering

Brake Caliper EV 028 EFM, supply voltage 400 VAC, electromagnet mounted in central position, thickness of brake disc 15 mm:

EV 028 EFM - 400 M - 12

## Advantages

The brake caliper EV 028 EFM or EH 028 EFM is a very compact and high efficient disc brake with very low power consumption. Its floating bearing compensates small misalignments of the brake disc. The attached electronic reduces automatically the power consumption in closed position to 20 W.

## Options

- Inductive proximity switch: "Brake released"-, "Brake closed"-status and/or "Friction block wear adjustment necessary"

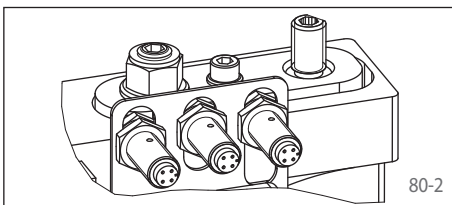

80-2

## Technical Data

	Brake Calipers EV 028 EFM and EH 028 EFM with supply voltage	
	230/240 VAC	380/400/415 VAC
Brake disc diameter	Braking torque	Braking torque
mm	Nm	Nm
300	700	1170
355	870	1450
430	1090	1820
520	1360	2270
630	1690	2820
710	1930	3220
Clamping force	7500 N	12500 N
Clamping force or braking torque adjustable	70 - 100%	70 - 100%
Power consumption in closed position	20 W (100% duty factor)	
Fuse rating	16A, time-lag	
Switching frequency	240/h permanent activations at 20° C ambient temperature	
Switching time*	at least 10 seconds	
Weight	24 kg	

The braking torques shown in the table are based on a theoretical friction coefficient of 0,4.

\* shorter switching time on request

# Brake Calipers EV 028 EFM and EH 028 EFM

electromagnetically activated – spring released

## Brake Caliper EV 028 EFM

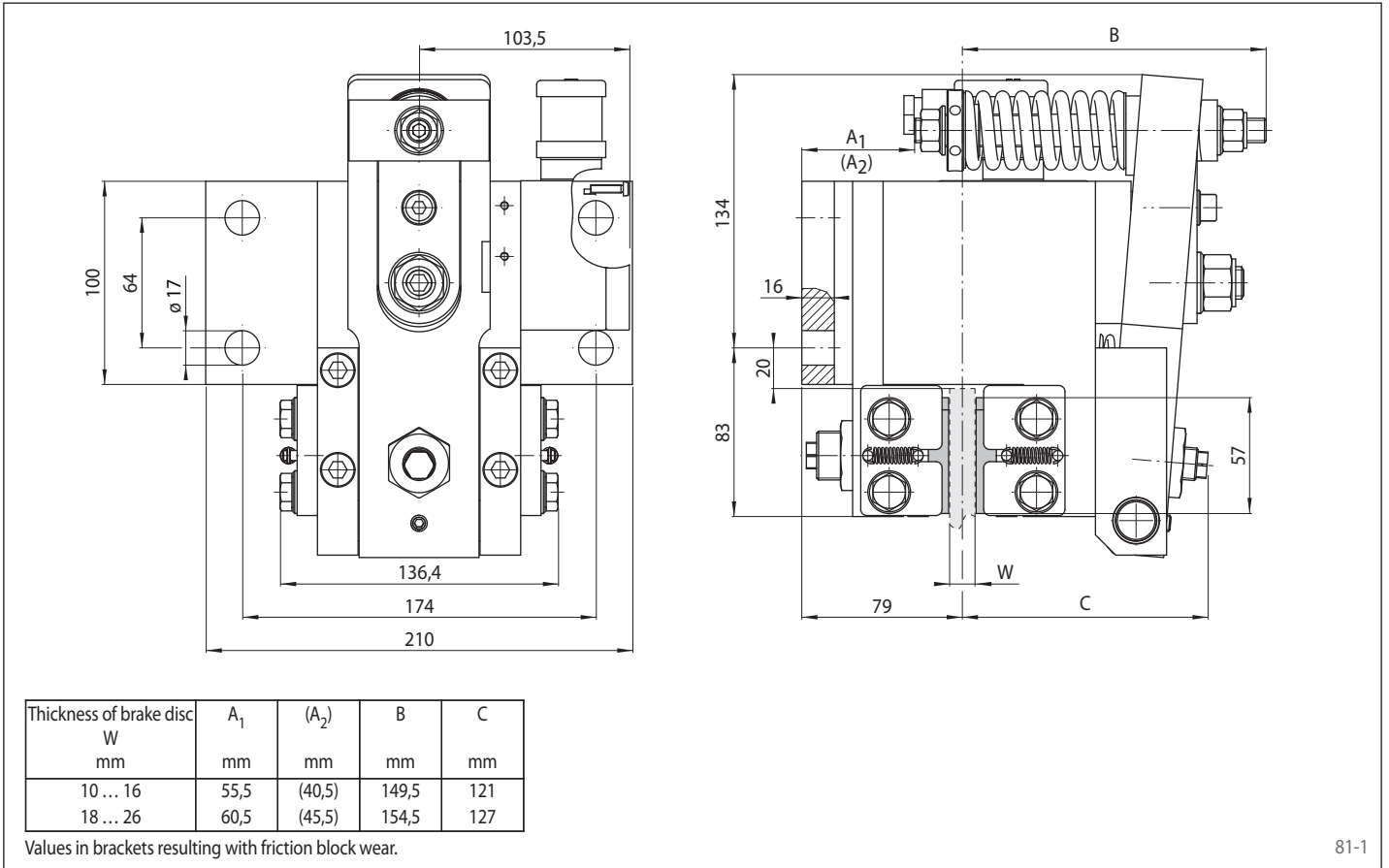

81-1

## Brake Caliper EH 028 EFM

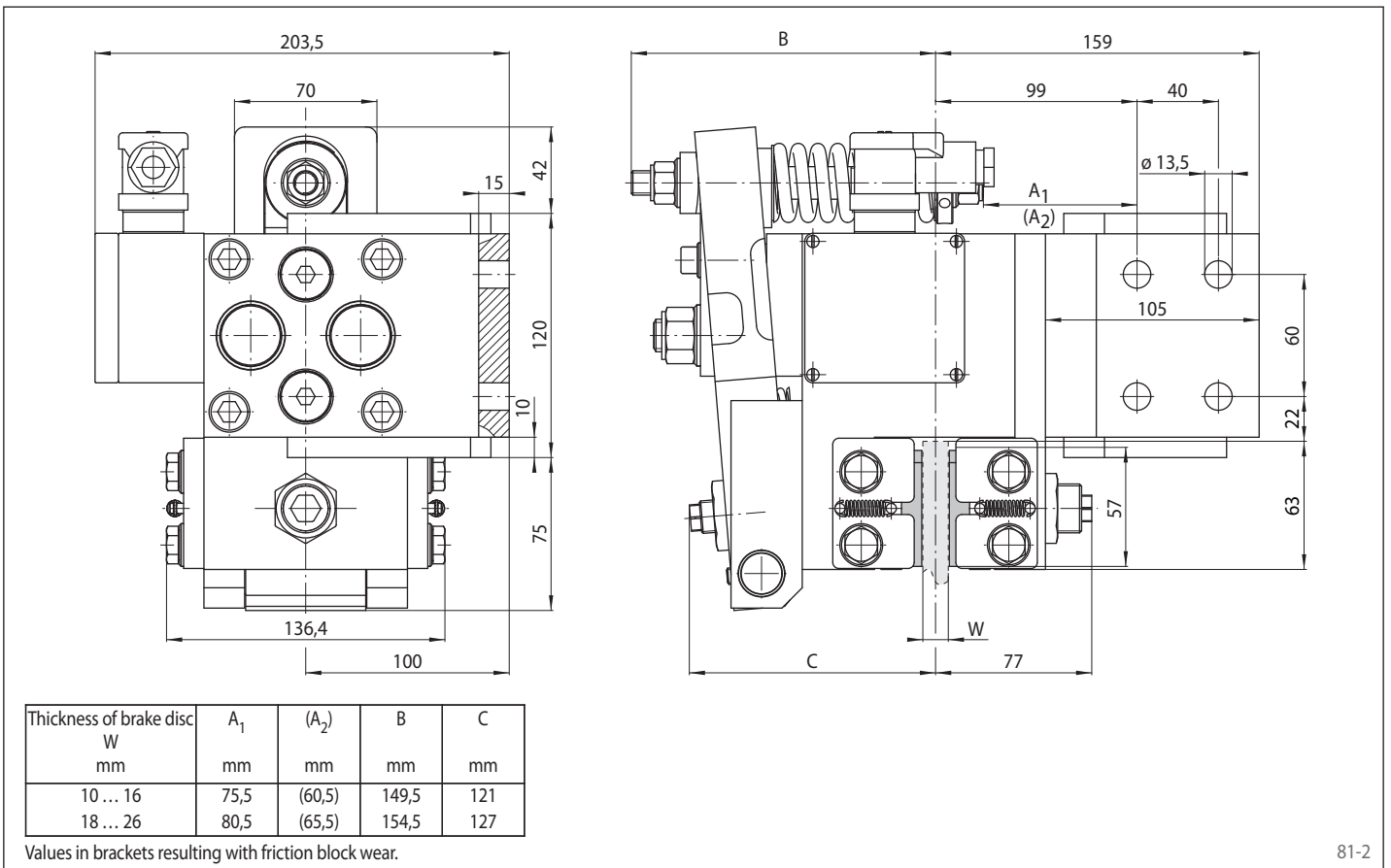

81-2

# Brake Calipers EV 038 EFM and EH 038 EFM

electromagnetically activated – spring released

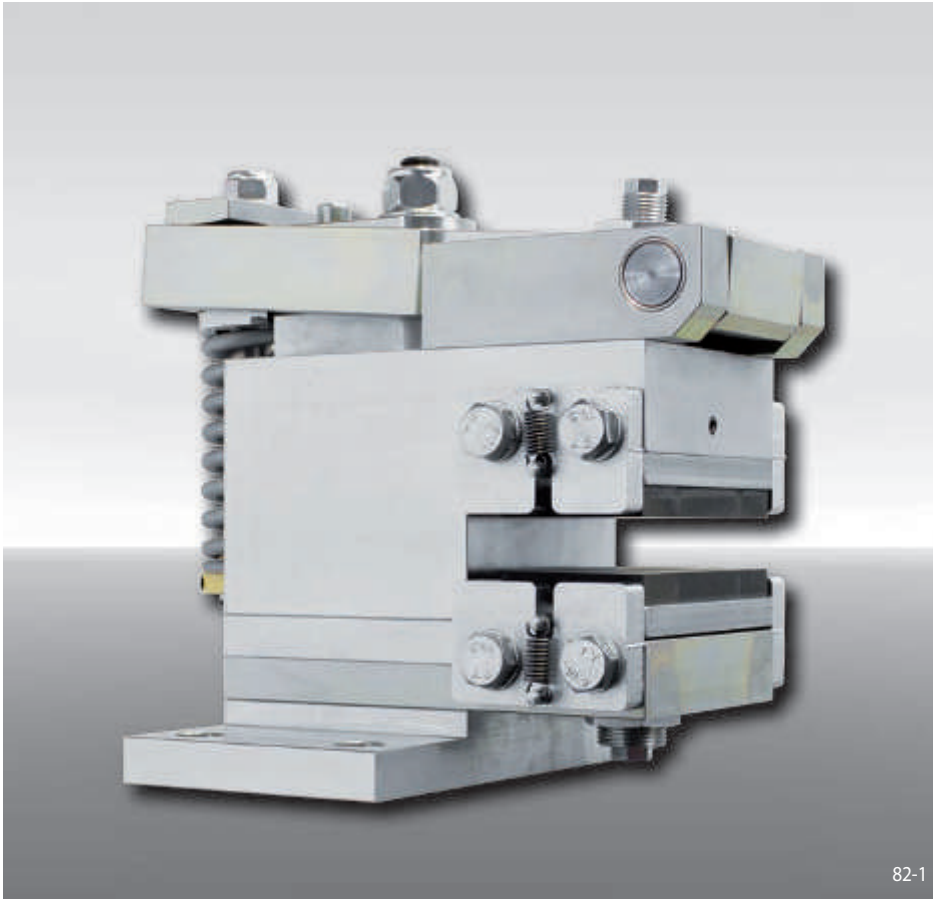

82-1

## Features

Features	Code
Brake Caliper with electromagnet	E
Mounting to the machine parallel or at right angles to the brake disc	V H
Frame size 038	038
Electromagnetically activated	E
Spring released	F
Manual adjustment to accommodate friction block wear	M
Supply voltage 380/400/415 VAC, supply frequency 50 Hz or 60 Hz adjustable	400
Electromagnet mounted in central position	M
Thickness of brake disc 12,5 ... 20 mm or 22 ... 30 mm	12 25

## Example for ordering

Brake Caliper EV 038 EFM, supply voltage 400 VAC, electromagnet mounted in central position, thickness of brake disc 25 mm:

EV 038 EFM - 400 M - 25

## Advantages

The brake caliper EV 038 EFM or EH 038 EFM is a very compact and high efficient disc brake with very low power consumption. Its floating bearing compensates small misalignments of the brake disc. The attached electronic reduces automatically the power consumption in closed position to 30 W.

## Options

- Inductive proximity switch: "Brake released", "Brake closed"-status and/or "Friction block wear adjustment necessary"

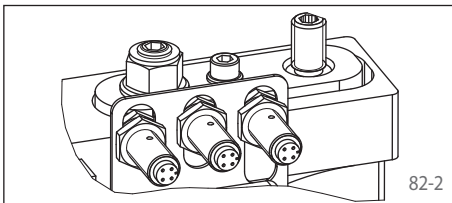

82-2

## Technical Data

Brake Calipers EV 038 EFM and EH 038 EFM with supply voltage 380/400/415 VAC	
Brake disc diameter	Braking torque
mm	Nm
430	3400
520	4250
630	5320
710	6090
800	6950
900	7910
Clamping force	24000 N
Clamping force or braking torque adjustable	70 - 100%
Power consumption in closed position	30 W (100% duty factor)
Fuse rating	16A, time-lag
Switching frequency	240/h permanent activations at 20° C ambient temperature
Switching time*	at least 10 seconds
Weight	50 kg

The braking torques shown in the table are based on a theoretical friction coefficient of 0,4.

\* shorter switching time on request

# Brake Calipers EV 038 EFM and EH 038 EFM

electromagnetically activated – spring released

## Brake Caliper EV 038 EFM

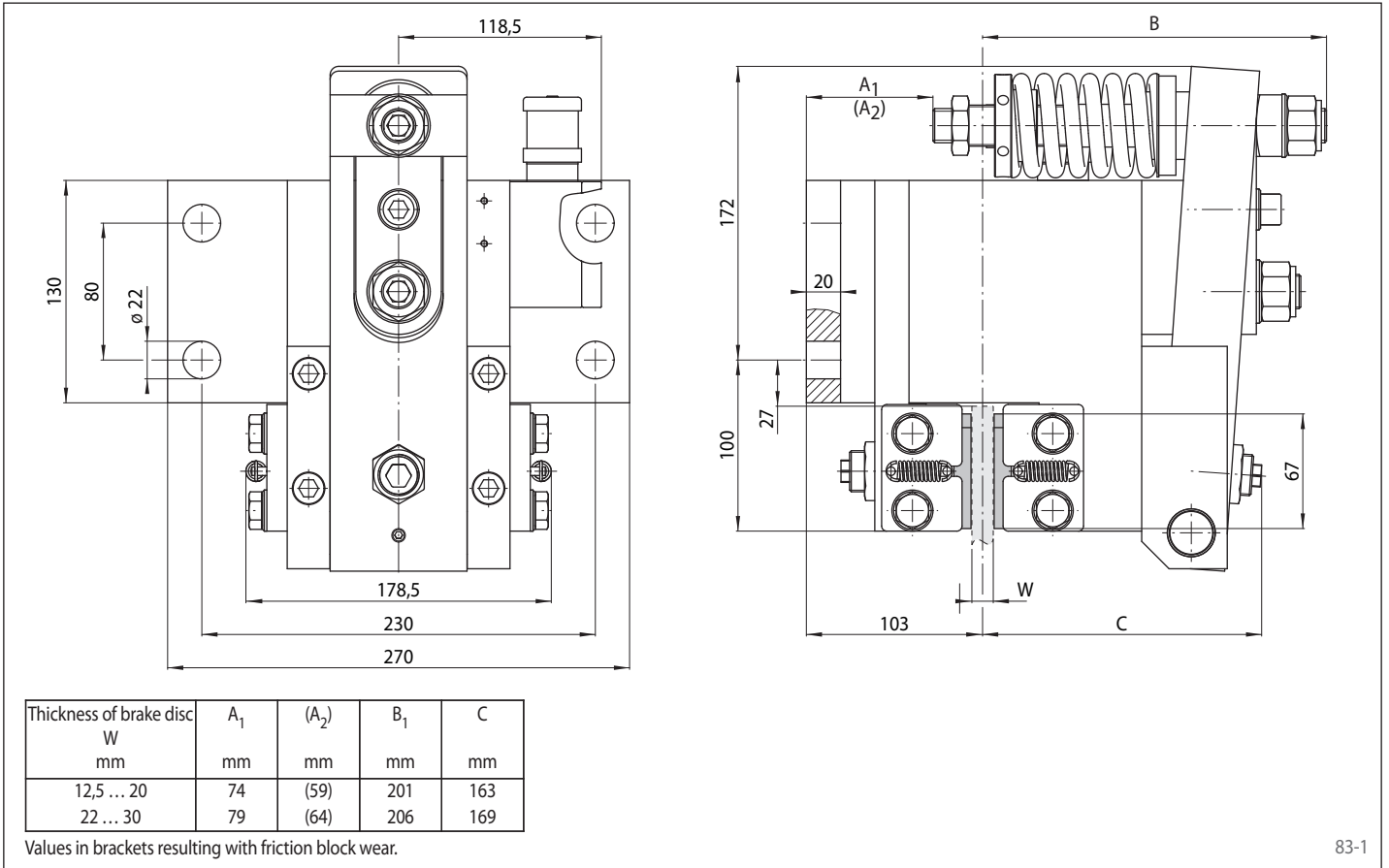

83-1

## Brake Caliper EH 038 EFM

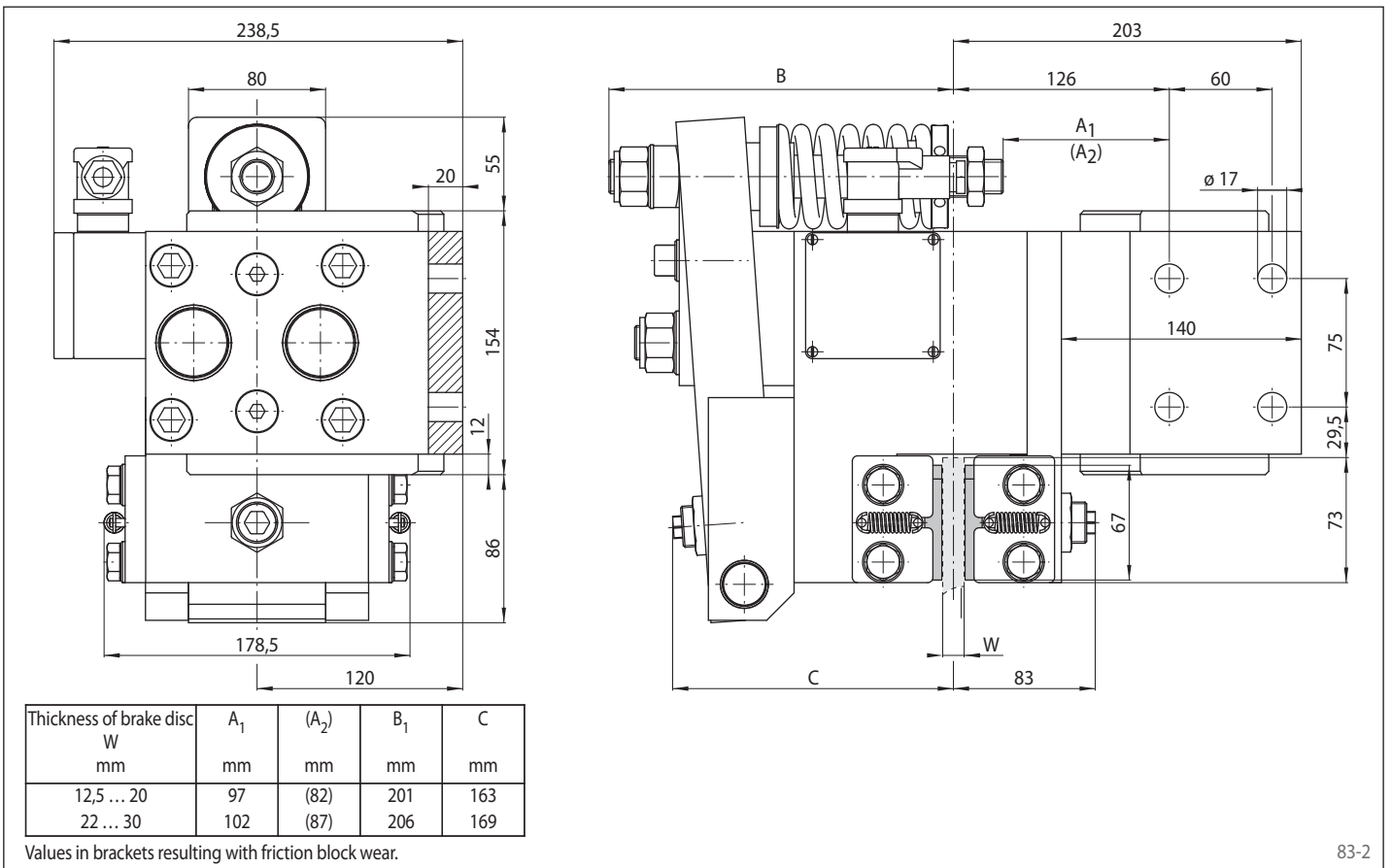

83-2



# Brake Caliper DH 010 MSM

manually activated – manually released  
with hand wheel

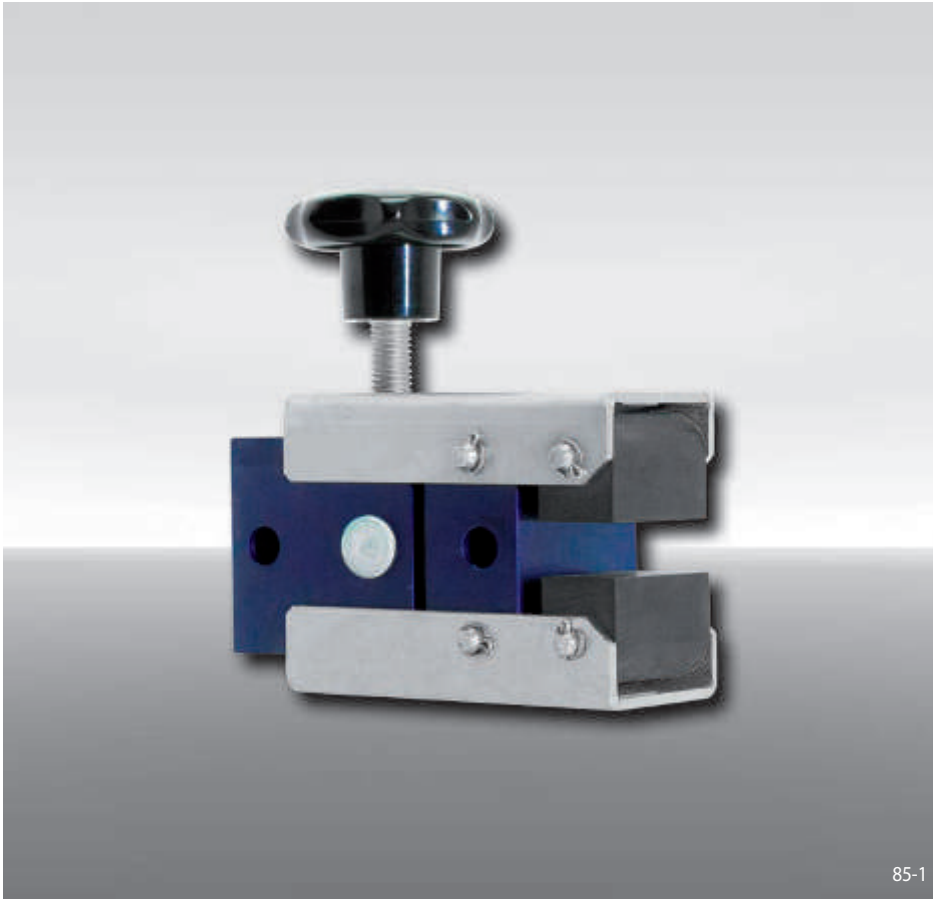

85-1

## Features

Features	Code
Brake Caliper	D
Mounting to the machine at right angles to the brake disc	H
Frame size 010	010
Manually activated	M
Manually released	S
Manual adjustment to accommodate friction block wear	M
Hand wheel 710	710
Hand wheel mounted right or left available	R L
Thickness of brake disc 12,5 mm	12

## Example for ordering

Brake Caliper DH 010 MSM, hand wheel 710, hand wheel mounted right, thickness of brake disc 12,5 mm:

DH 010 MSM - 710 R - 12

## Technical Data

Brake Caliper DH 010 MSM with hand wheel 710	
Brake disc diameter	Braking torque
mm	Nm
125	20
150	30
200	40
250	50
300	60
355	75
Clamping force	576 N
Weight	1,1 kg

The braking torques shown in the table are based on a theoretical friction coefficient of 0,4. The maximum braking torques are based on an operating torque of 0,8 Nm at the hand wheel.

A spring loaded threaded spindle compensates for wear of the friction block during the braking action.

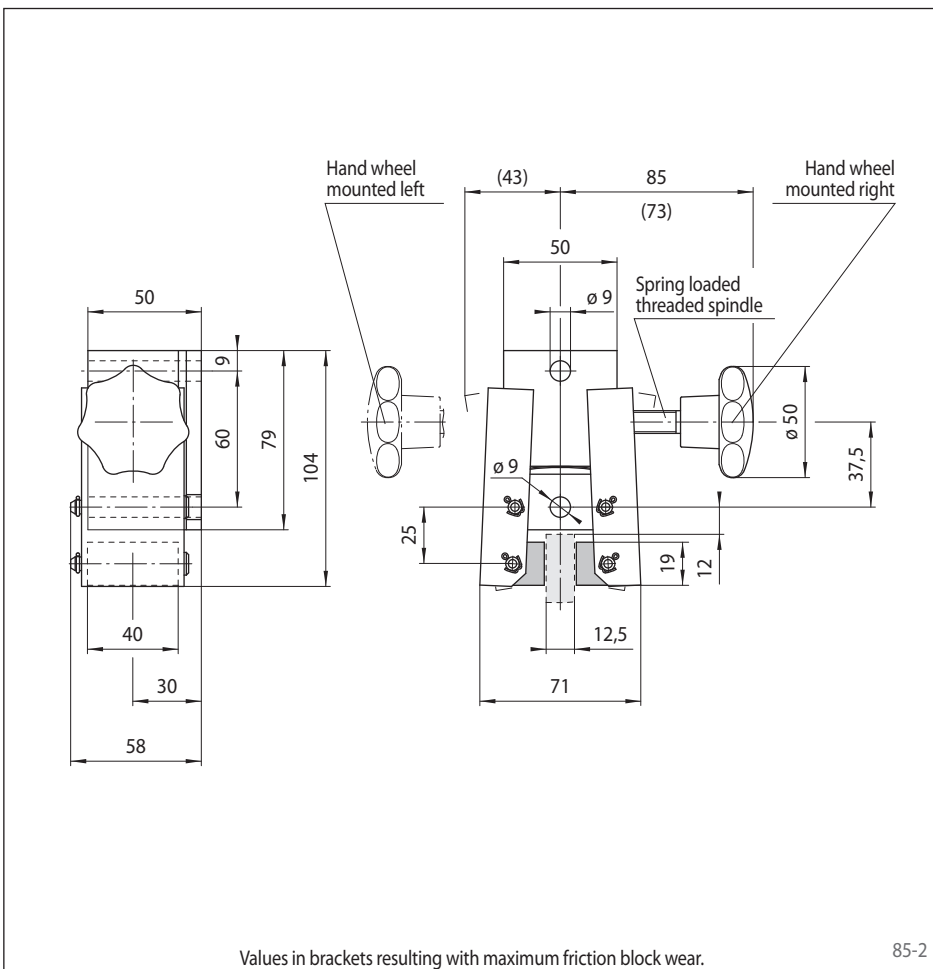

85-2





# Brake Caliper DH 020 MSM

manually activated – manually released  
with hand wheel

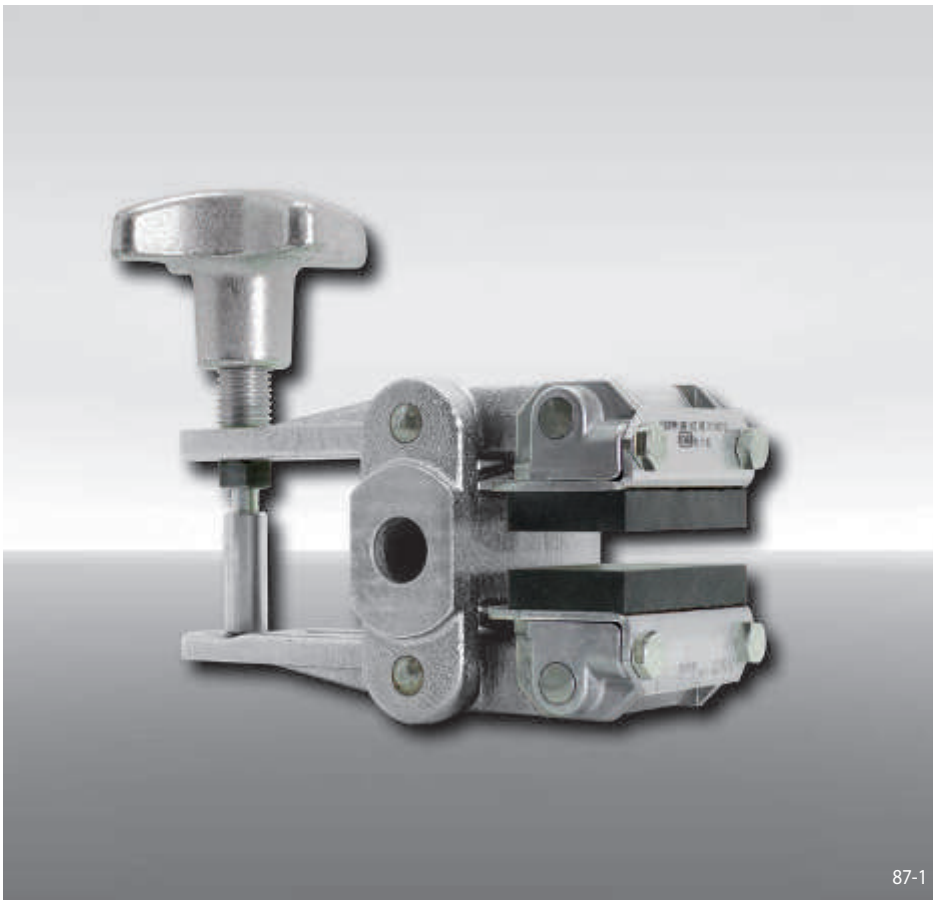

87-1

## Features

Features	Code
Brake Caliper	D
Mounting to the machine at right angles to the brake disc	H
Frame size 020	020
Manually activated	M
Manually released	S
Manual adjustment to accommodate friction block wear	M
Hand wheel 720	720
Position of the hand wheel to the right or left can be defined by turning the brake during installation	U
Thickness of brake disc 12,5 mm	12

## Example for ordering

Brake Caliper DH 020 MSM, hand wheel 720, position of the hand wheel can be to the right or left, thickness of brake disc 12,5 mm:

DH 020 MSM - 720 U - 12

## Technical Data

Brake Caliper DH 020 MSM with hand wheel 720	
Brake disc diameter	Braking torque
mm	Nm
200	160
250	215
300	270
355	335
430	420
520	520
Clamping force	2800 N
Weight	4,8 kg

The braking torques shown in the table are based on a theoretical friction coefficient of 0,4. The maximum braking torques are based on an operating torque of 7,7 Nm at the hand wheel.

A spring loaded threaded spindle compensates for wear of the friction block during the braking action.

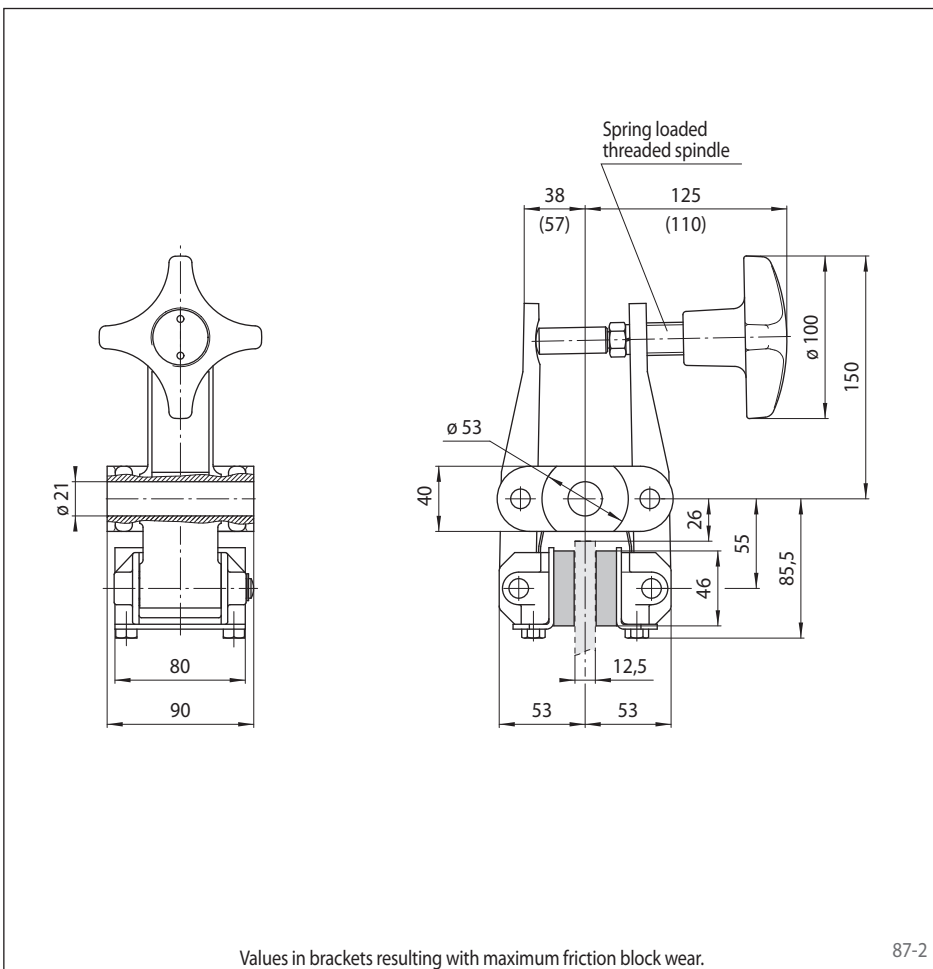

87-2



# Brake Caliper DH 020 MKM

manually activated – manually released  
by Pull Cable

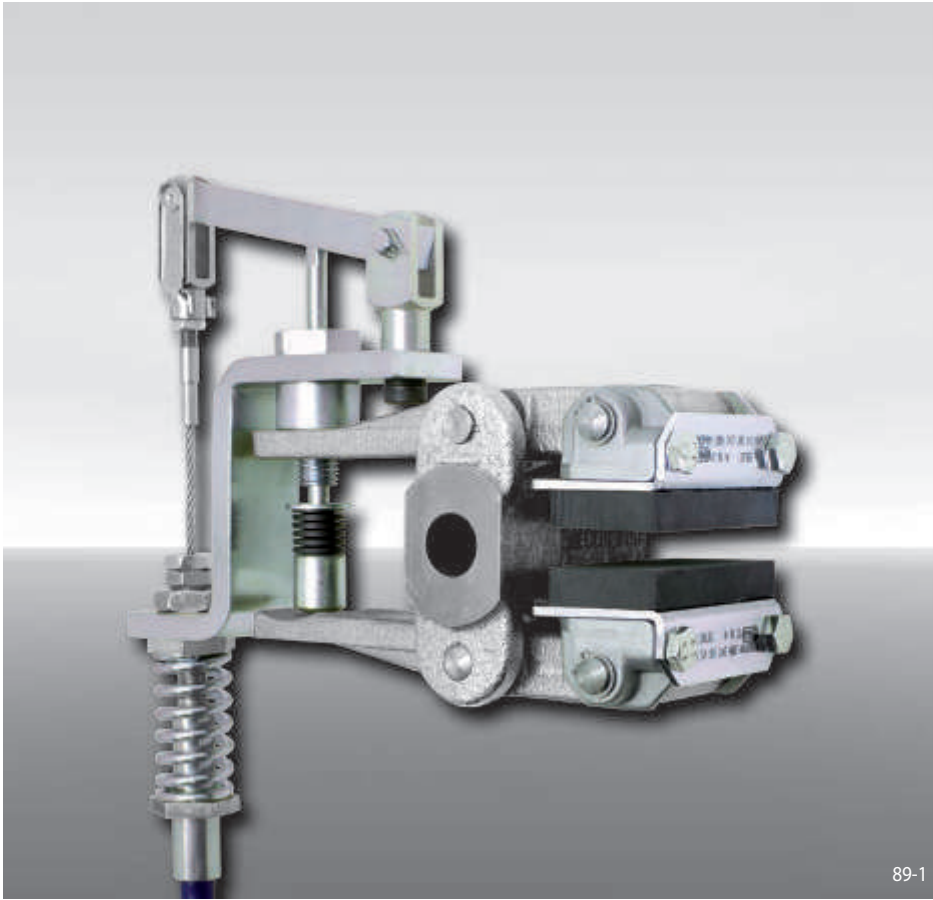

89-1

## Features

Features	Code
Brake Caliper	D
Mounting to the machine at right angles to the brake disc	H
Frame size 020	020
Manually activated	M
Manually released	K
Manual adjustment to accommodate friction block wear	M
Spring-loaded pressure pin 730	730
Position of the Pull Cable installation to the right or left can be defined by turning the brake during installation	U
Thickness of brake disc 12,5 mm	12

## Example for ordering

Brake Caliper DH 020 MKM, pressure pin 730, position of the Pull Cable installation can be to the right or left, thickness of brake disc 12,5 mm:

DH 020 MKM - 730 U - 12

## Technical Data

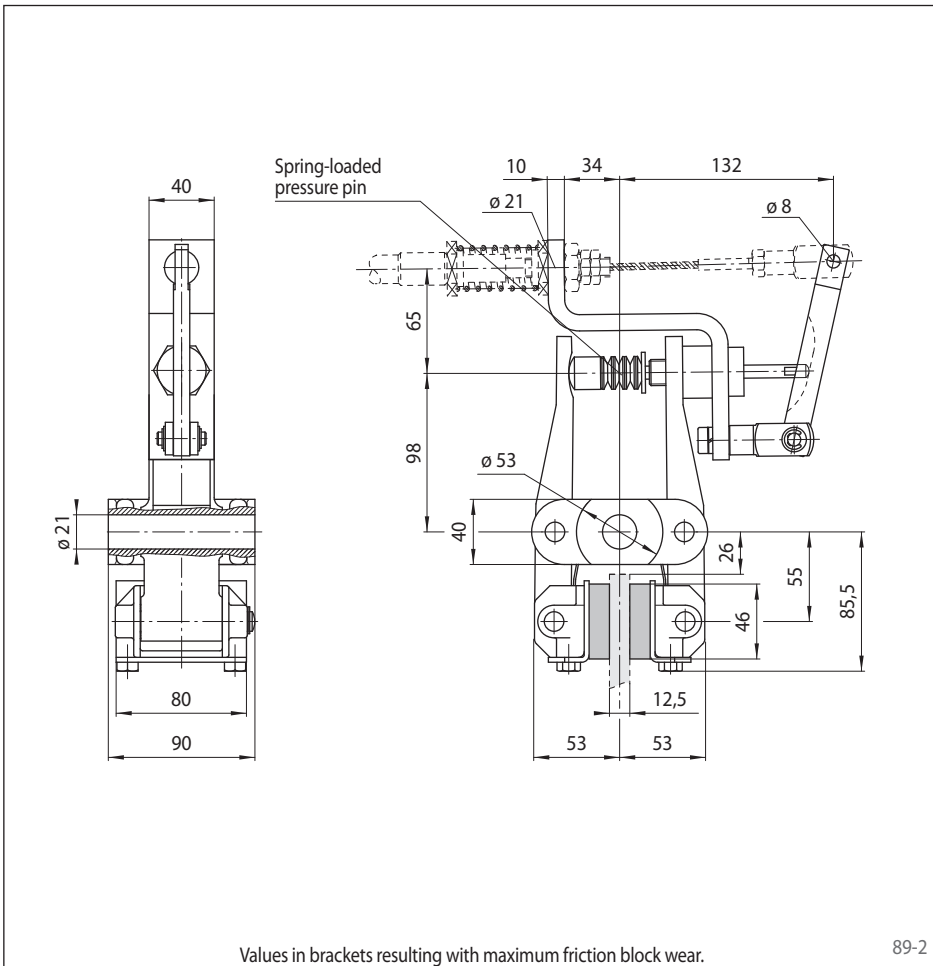

89-2

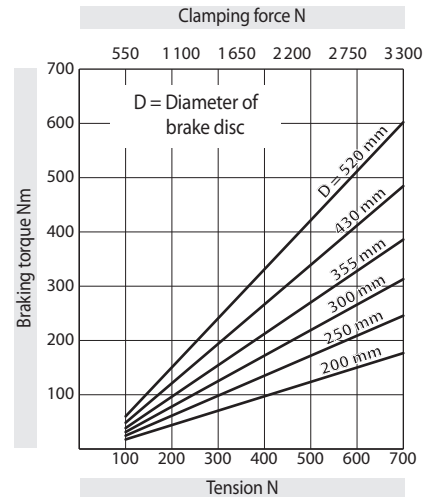

The braking torques shown in the diagram are based on a theoretical friction coefficient of 0,4.

Weight: 5,1 kg

## Accessories

The Brake Caliper can be delivered fully assembled with RCS® Pull Cable and Hand Brake Lever. Please indicate the required cable length.

For further information regarding RCS® Pull Cable and Hand Brake Lever see page 121.

A spring loaded pressure pin compensates for wear of the friction block during the braking action.

# Brake Caliper HS 075 FHM

spring activated – hydraulically released  
for wind turbines or conveyor systems

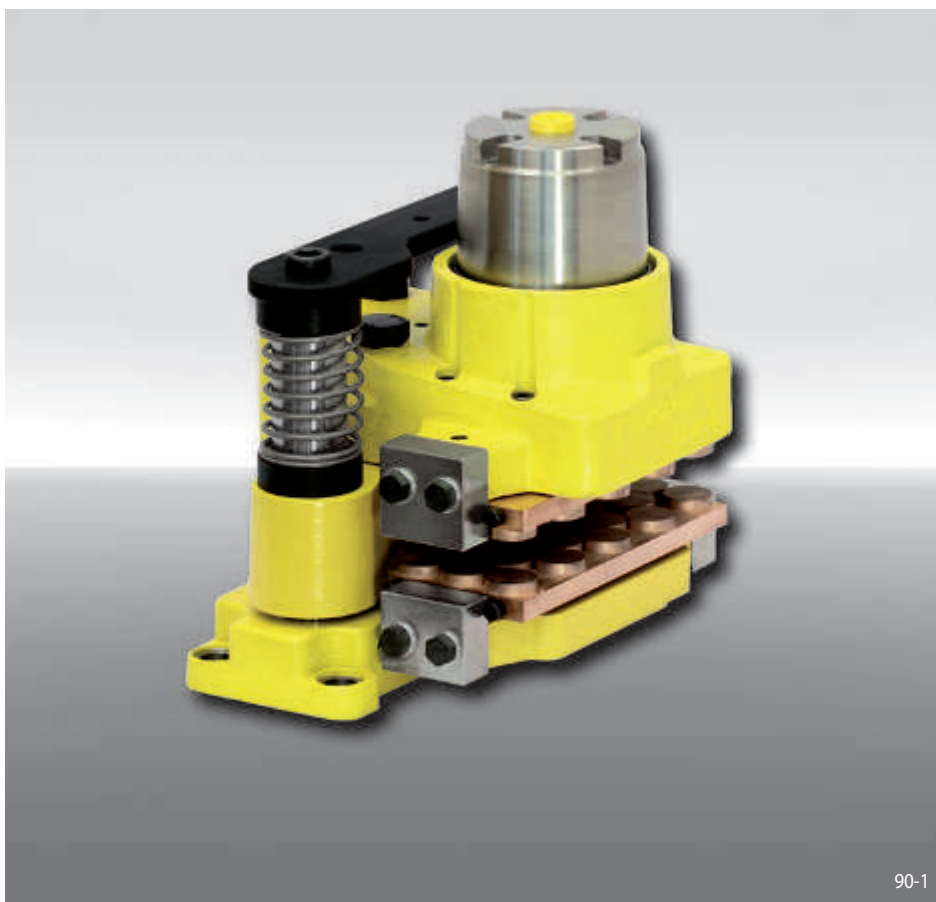

Features	Code
Brake Caliper	H
Floating caliper	S
With piston diameter 75 mm	075
Spring activated	F
Hydraulically released	H
Manual adjustment to accommodate friction block wear	M
Spring packages available for clamping forces of 10 kN, 20 kN, 30 kN, 40 kN or 55 kN	010 to 055

### Example for ordering

Brake Caliper HS 075 FHM, spring package for clamping force 10 kN:

HS 075 FHM - 010

## Technical Data

	Brake Caliper HS 075 FHM				
	with spring package 010	with spring package 020	with spring package 030	with spring package 040	with spring package 055
Brake disc diameter	Braking torque	Braking torque	Braking torque	Braking torque	Braking torque
mm	Nm	Nm	Nm	Nm	Nm
520	1500	3000	4400	5900	8100
630	1900	3800	5700	7600	10400
710	2200	4400	6600	8800	12100
900	3000	5900	8900	11900	16300
1250	4400	8700	13100	17500	24000
1600	5800	11500	17300	23100	31800
2000	7400	14700	22100	29500	40500
Clamping force	10 kN	20 kN	30 kN	40 kN	55 kN
Oil pressure	min. 25 bar max. 140 bar	min. 50 bar max. 140 bar	min. 70 bar max. 140 bar	min. 95 bar max. 140 bar	min. 125 bar max. 140 bar
Oil volume	max. 82 cm <sup>3</sup>	max. 82 cm <sup>3</sup>	max. 82 cm <sup>3</sup>	max. 82 cm <sup>3</sup>	max. 82 cm <sup>3</sup>
Weight	95 kg	95 kg	95 kg	95 kg	95 kg

The braking torques shown in the table are based on a theoretical friction coefficient of 0,4.



# Brake Caliper HS 075 FHM

spring activated – hydraulically released  
for wind turbines or conveyor systems

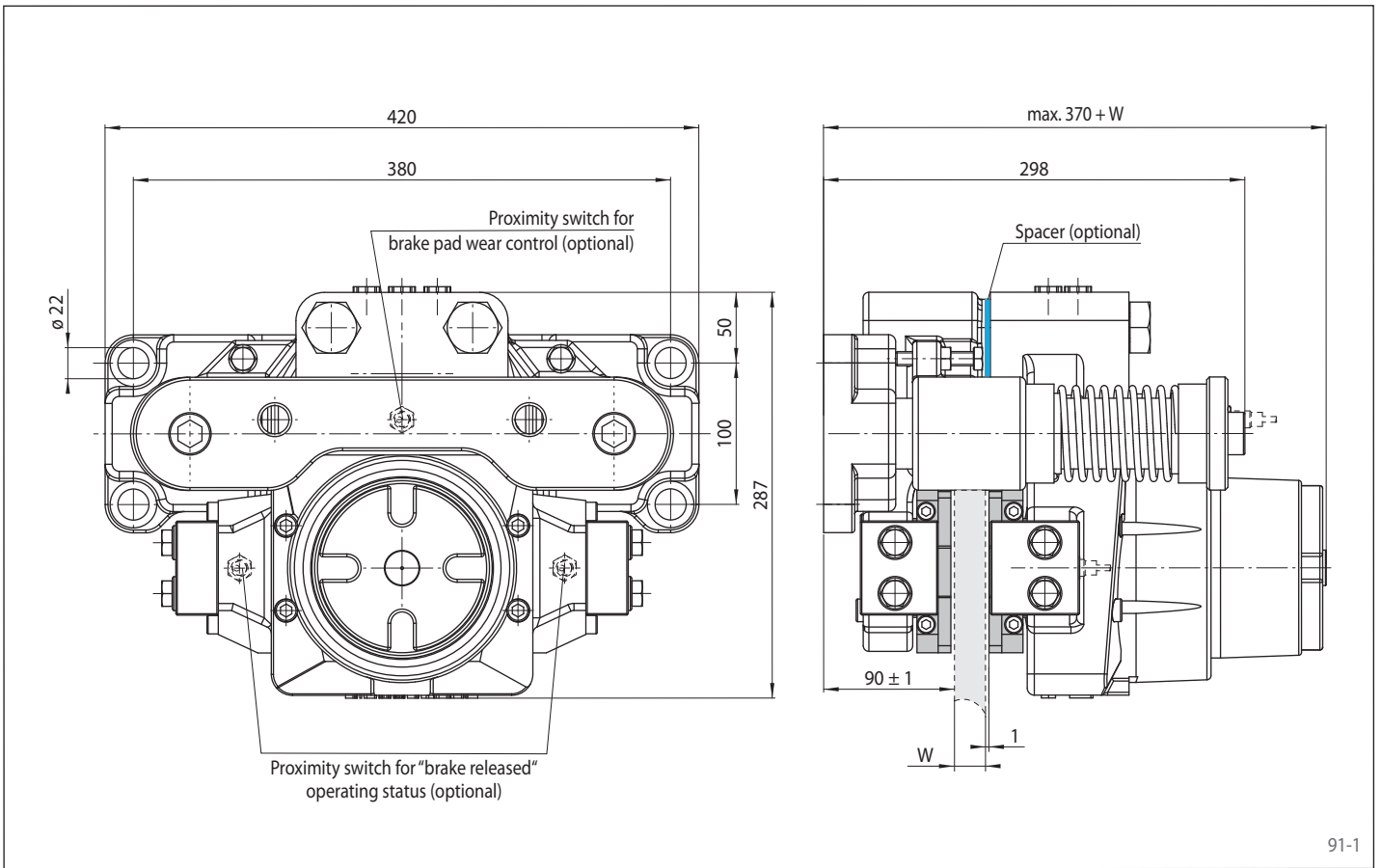

91-1

## Mounting

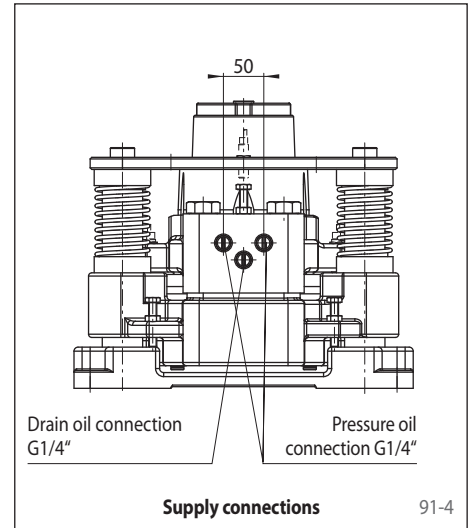
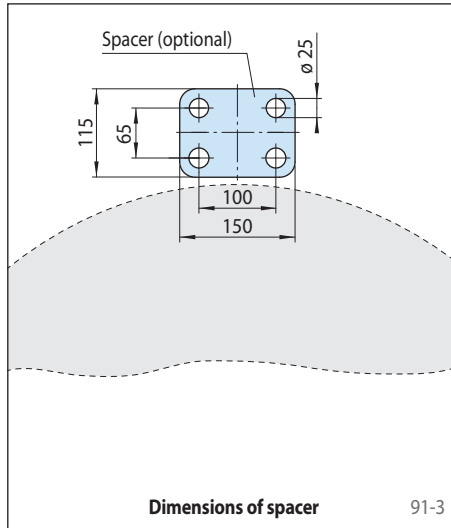
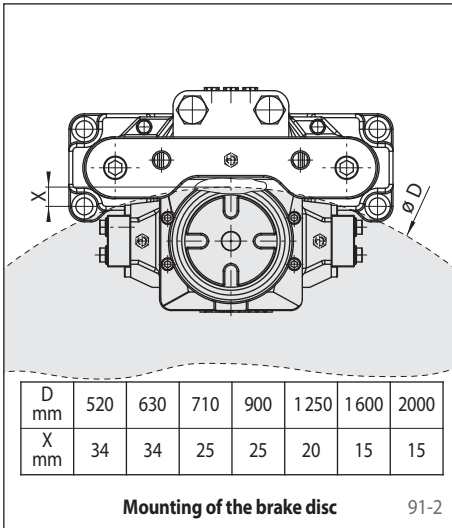

## Other features

- High safety against leakage
- Easy change of friction blocks
- Painted with surface coating class C4-L according to ISO 12944
- For brake disc thickness  $W = 20$  mm; brake disc thicknesses of up to 40 mm can be achieved with the use of a spacer installed by the customer

## Accessories

- Inductive proximity switch for "brake released" operating status
- Inductive proximity switch for brake pad wear control
- Optional painting with surface coating class C4-H or C5M-H (offshore) according to ISO 12944



# Brake Caliper HW 075 FHM

spring activated – hydraulically released

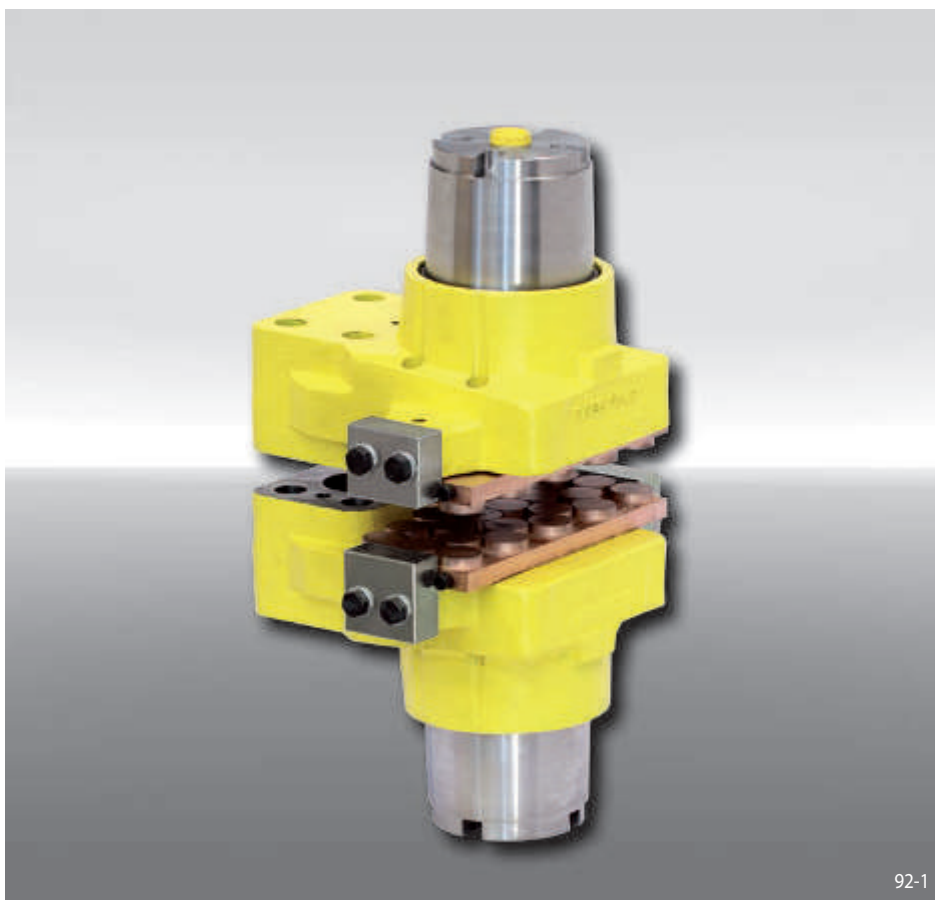

Features	Code
Brake Caliper	H
Standard	W
With piston diameter 75 mm	075
Spring activated	F
Hydraulically released	H
Manual adjustment to accommodate friction block wear	M
Spring packages available for clamping forces of 10 kN, 20 kN, 30 kN, 40 kN or 55 kN	010 to 055

### Example for ordering

Brake Caliper HW 075 FHM, spring package for clamping force 10 kN:

HW 075 FHM - 010

## Technical Data

	Brake Caliper HW 075 FHM				
	with spring package 010	with spring package 020	with spring package 030	with spring package 040	with spring package 055
Brake disc diameter	Braking torque	Braking torque	Braking torque	Braking torque	Braking torque
mm	Nm	Nm	Nm	Nm	Nm
520	1500	3000	4400	5900	8100
630	1900	3800	5700	7600	10400
710	2200	4400	6600	8800	12100
900	3000	5900	8900	11900	16300
1250	4400	8700	13100	17500	24000
1600	5800	11500	17300	23100	31800
2000	7400	14700	22100	29500	40500
Clamping force	10 kN	20 kN	30 kN	40 kN	55 kN
Oil pressure	min. 25 bar max. 140 bar	min. 50 bar max. 140 bar	min. 70 bar max. 140 bar	min. 95 bar max. 140 bar	min. 125 bar max. 140 bar
Oil volume	max. 89 cm <sup>3</sup>	max. 89 cm <sup>3</sup>	max. 89 cm <sup>3</sup>	max. 89 cm <sup>3</sup>	max. 89 cm <sup>3</sup>
Weight	90 kg	90 kg	90 kg	90 kg	90 kg

The braking torques shown in the table are based on a theoretical friction coefficient of 0,4.

# Brake Caliper HW 075 FHM

spring activated – hydraulically released

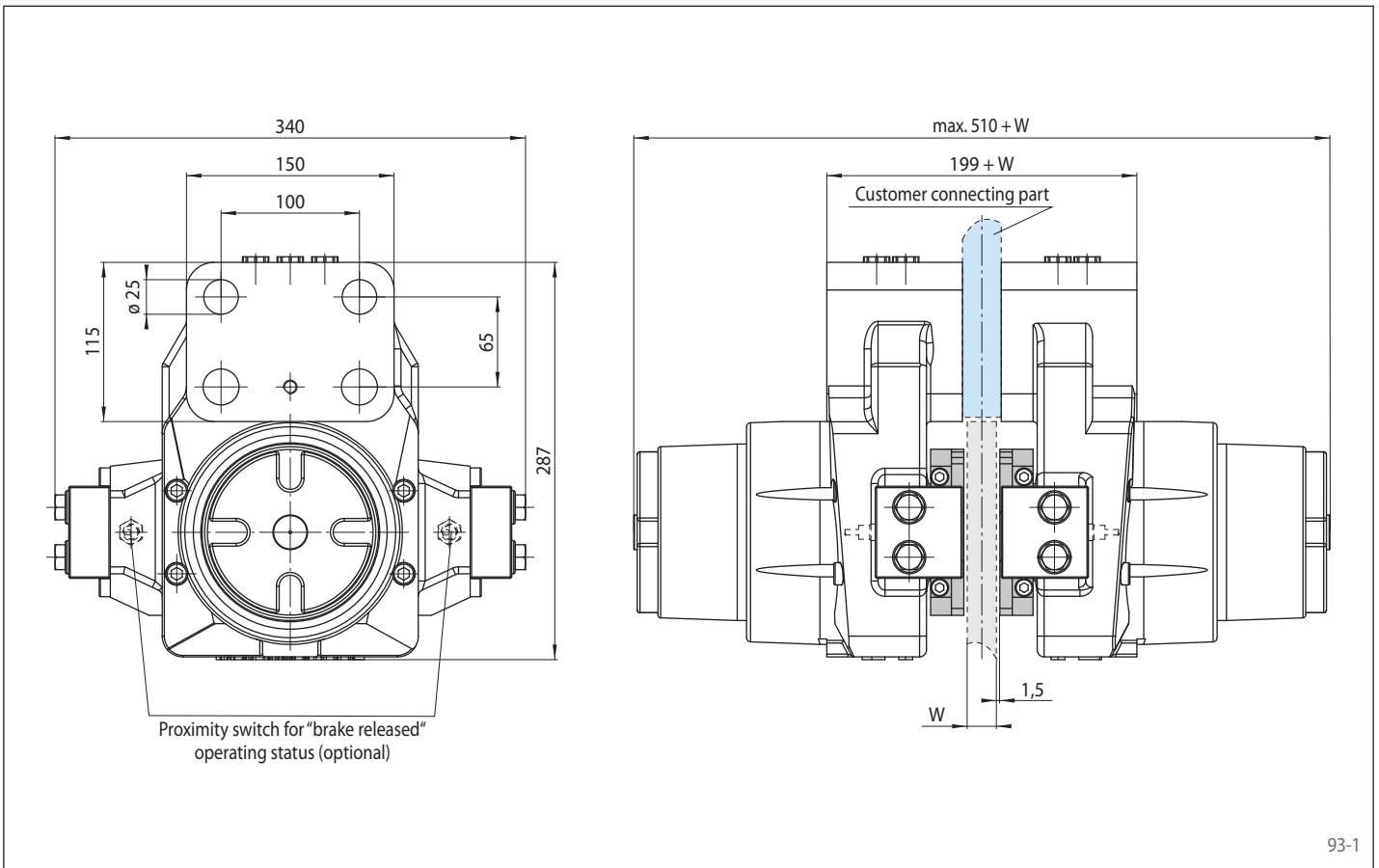

## Mounting

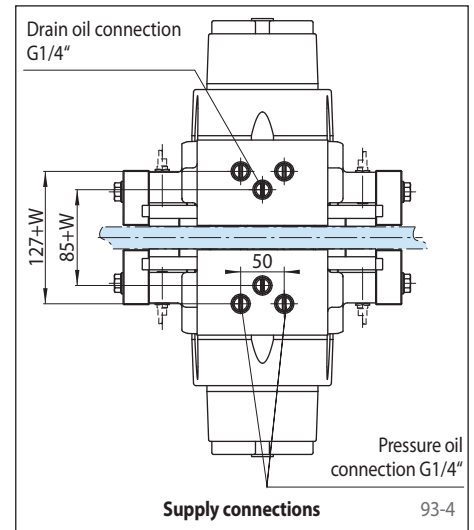
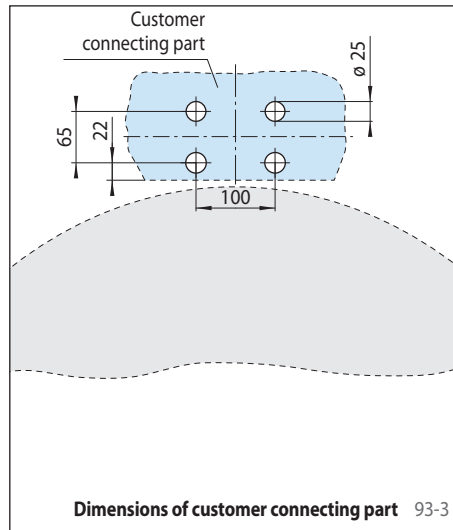
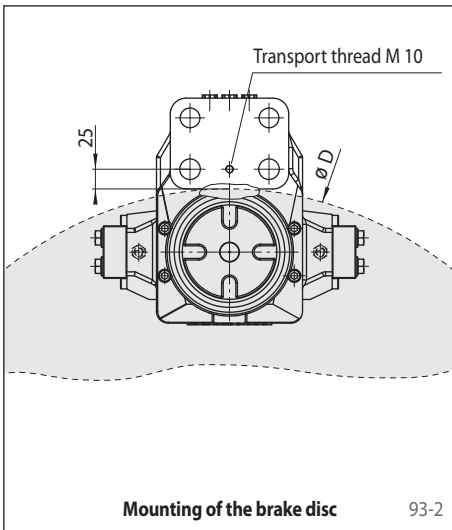

## Other features

- High safety against leakage
- Easy change of friction blocks
- Painted with surface coating class C4-L according to ISO 12944
- The thickness of the customer connecting part results from the thickness of the brake disc  $W$  plus 3 mm

## Accessories

- Inductive proximity switch for "brake released" operating status
- Optional painting with surface coating class C4-H or C5M-H (offshore) according to ISO 12944

# Brake Caliper HS 120 FHM

spring activated – hydraulically released  
for wind turbines or conveyor systems



Features	Code
Brake Caliper	H
Floating caliper	S
With piston diameter 120 mm	120
Spring activated	F
Hydraulically released	H
Manual adjustment to accommodate friction block wear	M
Spring packages available for clamping forces of 30 kN, 50 kN, 70 kN, 100 kN or 120 kN	030 to 120

### Example for ordering

Brake Caliper HS 120 FHM, spring package for clamping force 30 kN:

HS 120 FHM - 030

## Technical Data

	Brake Caliper HS 120 FHM				
	with spring package 030	with spring package 050	with spring package 070	with spring package 100	with spring package 120
Brake disc diameter	Braking torque	Braking torque	Braking torque	Braking torque	Braking torque
mm	Nm	Nm	Nm	Nm	Nm
900	8400	14000	19600	28000	33600
1250	12600	21000	29400	42000	50400
1600	16800	28000	39200	56000	67200
2000	21600	36000	50400	72000	86400
3000	33600	56000	91800	112000	134400
3500	39600	66000	108200	132000	158400
4000	45600	76000	124600	152000	182400
Clamping force	30 kN	50 kN	70 kN	100 kN	120 kN
Oil pressure	min. 50 bar max. 200 bar	min. 80 bar max. 200 bar	min. 110 bar max. 200 bar	min. 140 bar max. 200 bar	min. 180 bar max. 200 bar
Oil volume	max. 160 cm <sup>3</sup>	max. 160 cm <sup>3</sup>	max. 160 cm <sup>3</sup>	max. 160 cm <sup>3</sup>	max. 160 cm <sup>3</sup>
Weight	ca. 200 kg	ca. 200 kg	ca. 200 kg	ca. 200 kg	ca. 200 kg

The braking torques shown in the table are based on a theoretical friction coefficient of 0,4.

# Brake Caliper HS 120 FHM

spring activated – hydraulically released  
for wind turbines or conveyor systems

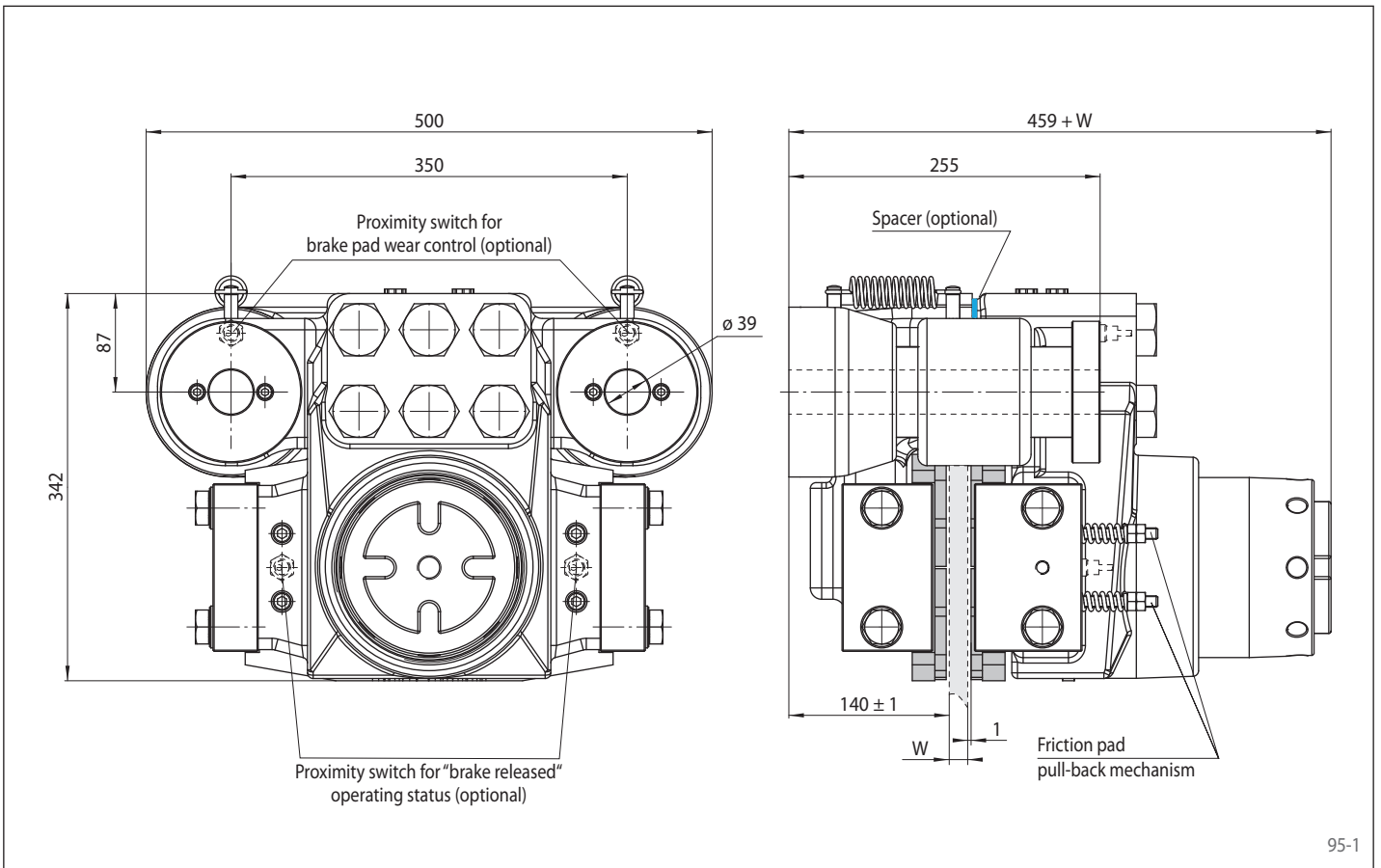

95-1

## Mounting

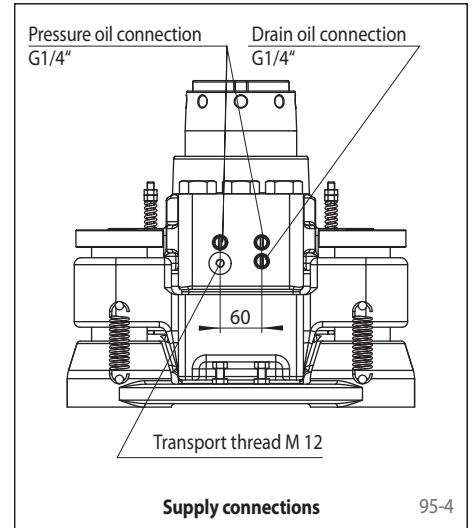
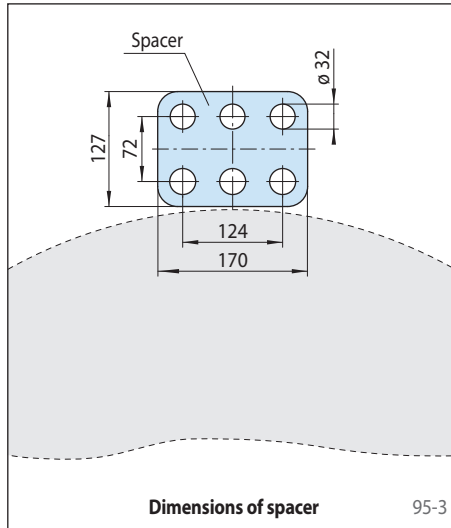
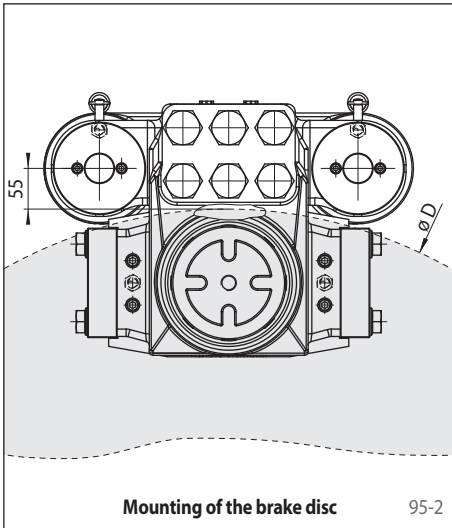

## Other features

- High safety against leakage
- Easy change of friction blocks
- Painted with surface coating class C4-L according to ISO 12944
- For brake disc thickness  $W = 20$  mm; brake disc thicknesses of up to 40 mm can be achieved with the use of a spacer installed by the customer

## Accessories

- Inductive proximity switch for "brake released" operating status
- Inductive proximity switch for brake pad wear control
- Optional painting with surface coating class C4-H or C5M-H (offshore) according to ISO 12944

# Brake Caliper HW 120 FHM

spring activated – hydraulically released



Features	Code
Brake Caliper	H
Standard	W
With piston diameter 120 mm	120
Spring activated	F
Hydraulically released	H
Manual adjustment to accommodate friction block wear	M
Spring packages available for clamping forces of 30 kN, 50 kN, 70 kN, 100 kN or 120 kN	030 to 120

### Example for ordering

Brake Caliper HW 120 FHM, spring package for clamping force 30 kN:

HW 120 FHM - 030

## Technical Data

	Brake Caliper HW 120 FHM				
	with spring package 030	with spring package 050	with spring package 070	with spring package 100	with spring package 120
Brake disc diameter	Braking torque	Braking torque	Braking torque	Braking torque	Braking torque
mm	Nm	Nm	Nm	Nm	Nm
900	8400	14000	19600	28000	33600
1250	12600	21000	29400	42000	50400
1600	16800	28000	39200	56000	67200
2000	21600	36000	50400	72000	86400
3000	33600	56000	91800	112000	134400
3500	39600	66000	108200	132000	158400
4000	45600	76000	124600	152000	182400
Clamping force	30 kN	50 kN	70 kN	100 kN	120 kN
Oil pressure	min. 50 bar max. 200 bar	min. 80 bar max. 200 bar	min. 110 bar max. 200 bar	min. 140 bar max. 200 bar	min. 180 bar max. 200 bar
Oil volume	max. 170 cm <sup>3</sup>	max. 170 cm <sup>3</sup>	max. 170 cm <sup>3</sup>	max. 170 cm <sup>3</sup>	max. 170 cm <sup>3</sup>
Weight	ca. 185 kg	ca. 185 kg	ca. 185 kg	ca. 185 kg	ca. 185 kg

The braking torques shown in the table are based on a theoretical friction coefficient of 0,4.

# Brake Caliper HW 120 FHM

spring activated – hydraulically released

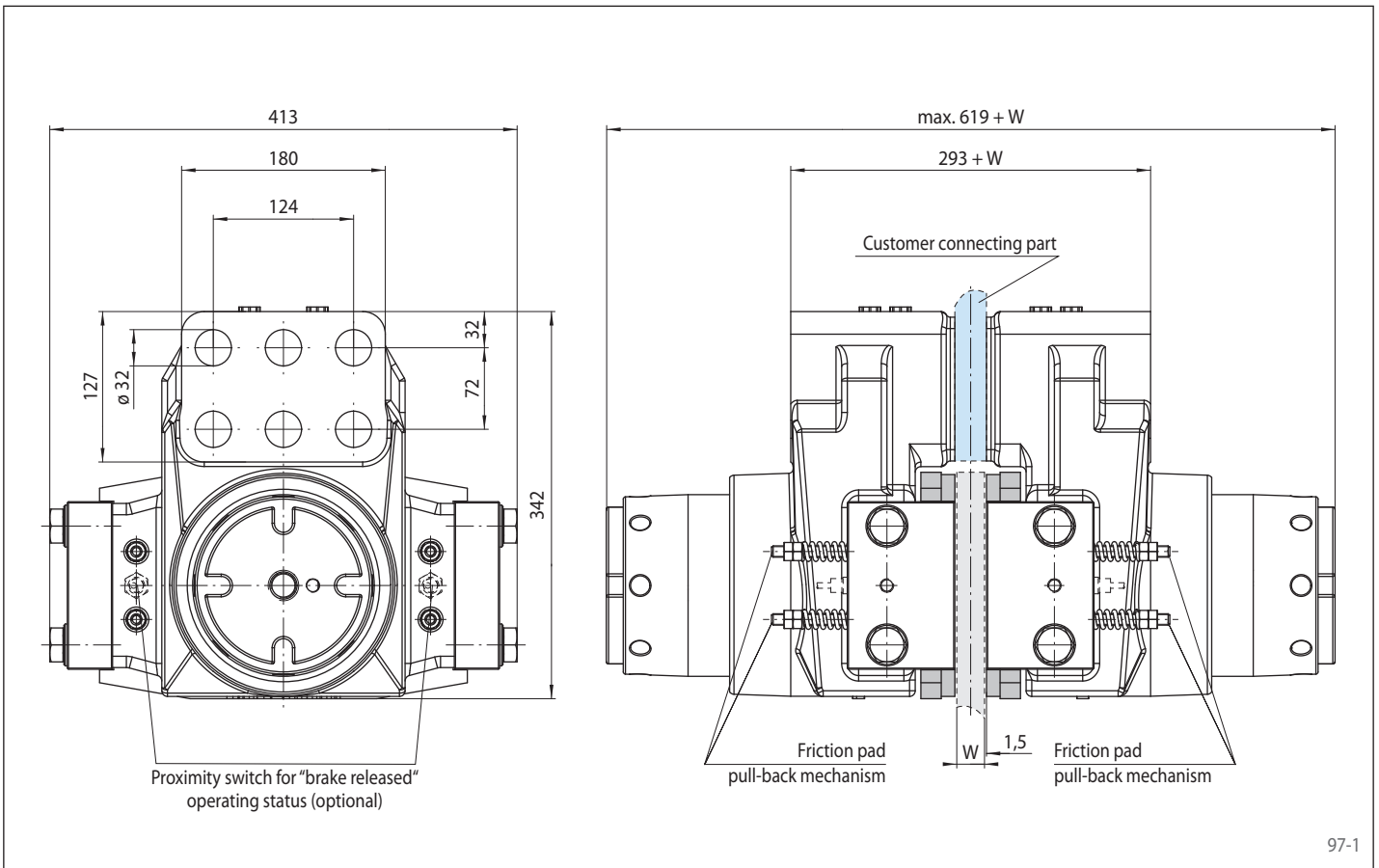

97-1

## Mounting

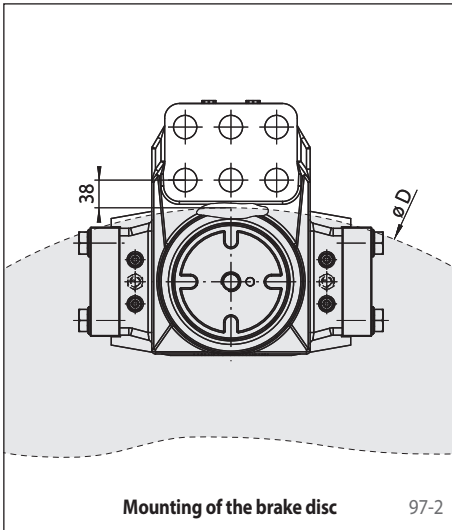

Mounting of the brake disc

97-2

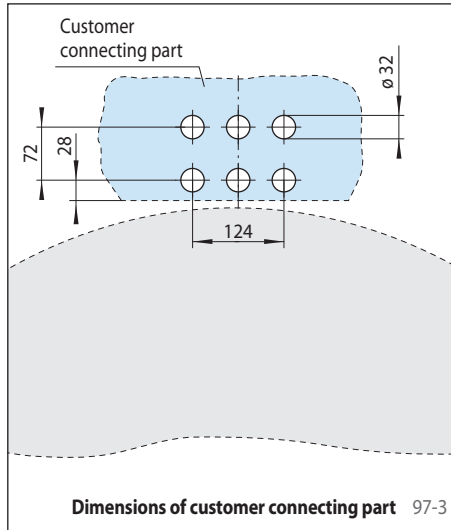

Dimensions of customer connecting part

97-3

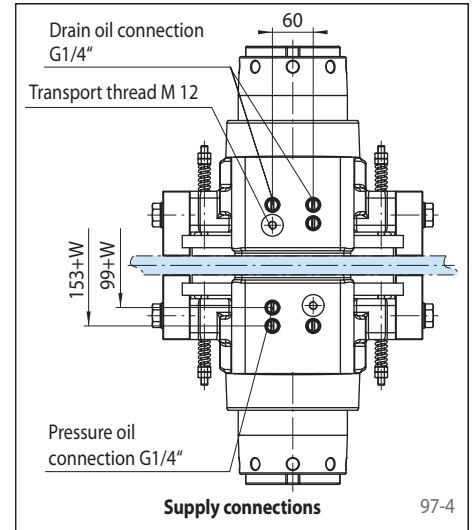

Supply connections

97-4

## Other features

- High safety against leakage
- Easy change of friction blocks
- Painted with surface coating class C4-L according to ISO 12944
- The thickness of the customer connecting part results from the thickness of the brake disc  $W$  plus 3 mm

## Accessories

- Inductive proximity switch for "brake released" operating status
- Optional painting with surface coating class C4-H or C5M-H (offshore) according to ISO 12944



# Brake Calipers HI 150 HUK and HI 180 HUK

hydraulically activated – non-releasing  
as yaw brake in wind turbines



## Features

Features	Code
Brake Caliper	H
With inside-mounted brake pads	I
With piston diameter 2 x 75 mm or piston diameter 2 x 90 mm	150 180
Hydraulically activated	H
Non-releasing	U
No adjustment to accommodate friction block wear	K
Max. clamping force 140 kN (HI 150) Max. clamping force 200 kN (HI 180)	140 200

## Example for ordering

Brake Caliper HI 150 HUK,  
max. clamping force 140 kN:

HI 150 HUK - 140

## Technical Data

### Brake Caliper HI 150 HUK

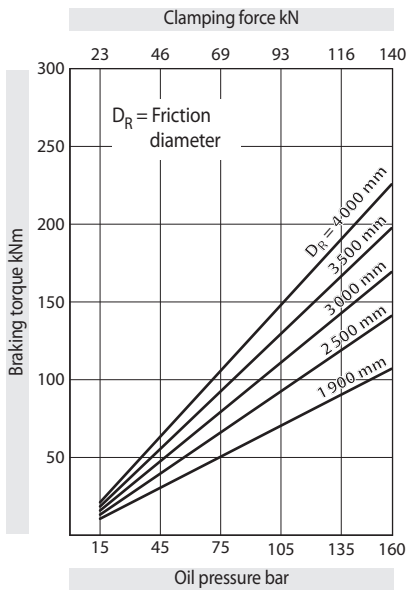

The braking torques shown in the diagram are based on a theoretical friction coefficient of 0,4.

Oil pressure: min. 15 bar  
max. 160 bar

Oil volume: max. 133 cm<sup>3</sup>

Weight: ca. 65 kg

### Brake Caliper HI 180 HUK

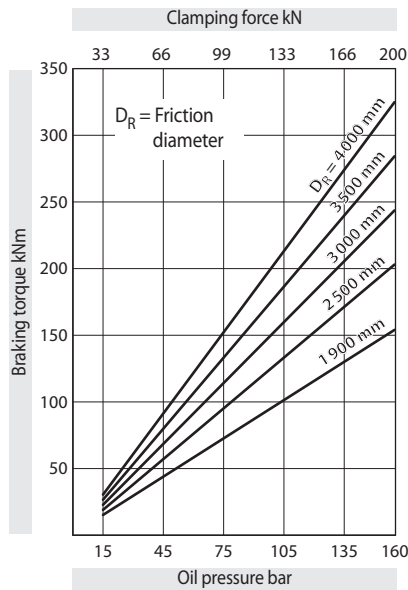

The braking torques shown in the diagram are based on a theoretical friction coefficient of 0,4.

Oil pressure: min. 15 bar  
max. 160 bar

Oil volume: max. 190 cm<sup>3</sup>

Weight: ca. 65 kg

## Other features

- High safety against leakage
- Painted with surface coating class C4-L according to ISO 12944
- For brake disc thickness  $W = 30$  mm; larger brake disc thicknesses can be achieved with the use of a spacer installed by the customer

## Accessories

- Optional painting with surface coating class C4-H or C5M-H (offshore) according to ISO 12944

# Brake Calipers HI 150 HUK and HI 180 HUK

hydraulically activated – non-releasing  
as yaw brake in wind turbines

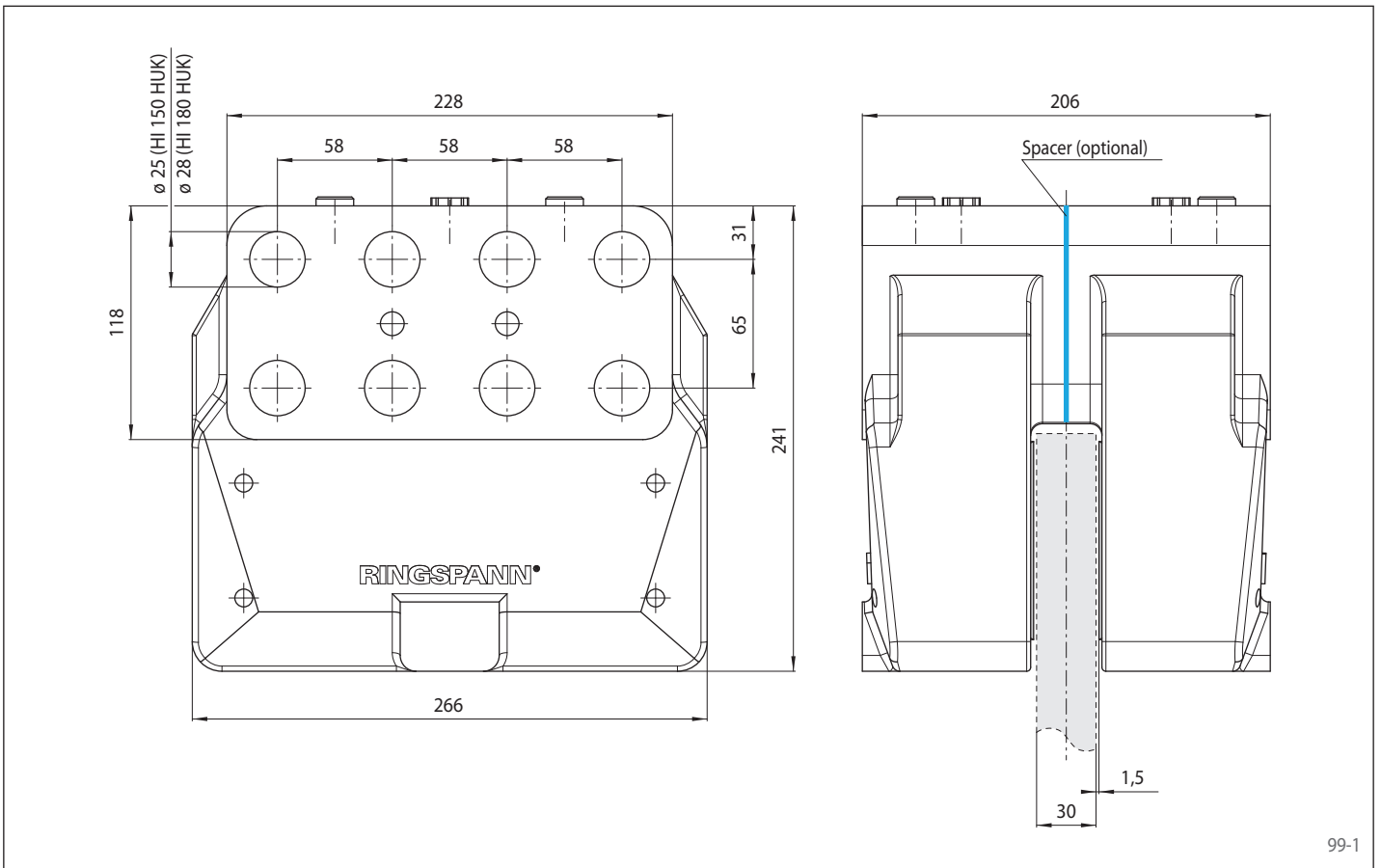

99-1

## Mounting

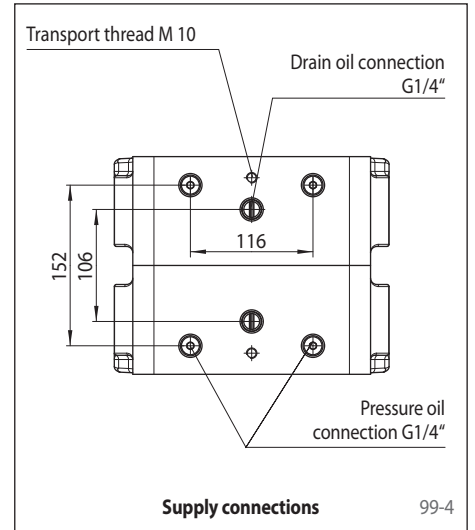
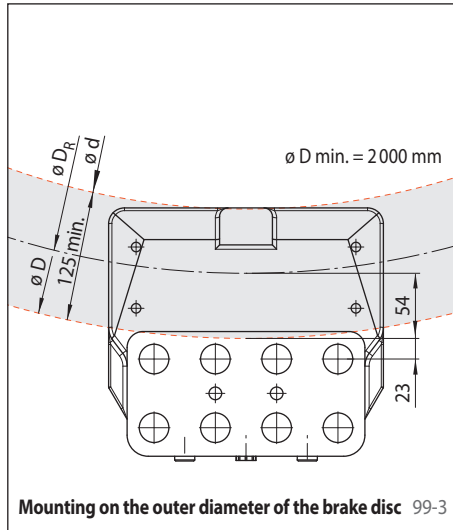
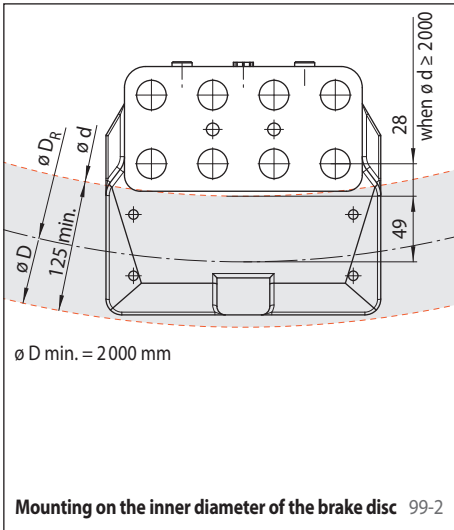

### Calculation of the friction diameter

Mounting on the inner diameter of the brake disc:

$$D_R = d + (2 \cdot 49 \text{ mm})$$

(when  $d \geq 2000 \text{ mm}$ )

Mounting on the outer diameter of the brake disc:

$$D_R = D - (2 \cdot 54 \text{ mm})$$

### Calculation of the braking torque

HI 150 HUK:

$$M_B = \frac{D_R}{1,132} \cdot p \cdot \mu$$

HI 180 HUK:

$$M_B = \frac{D_R}{0,786} \cdot p \cdot \mu$$

### Formula symbols

- $M_B$  = Braking torque [Nm]
- $D$  = Outer diameter brake disc [mm]
- $d$  = Inner diameter brake disc [mm]
- $D_R$  = Friction diameter [mm]
- $p$  = Oil pressure [bar]
- $\mu$  = Friction coefficient

# Brake Calipers HW 150 HUK and HW 180 HUK

hydraulically activated – non-releasing  
as yaw brake in wind turbines



Features	Code
Brake Caliper	H
Standard	W
With piston diameter 2 x 75 mm or piston diameter 2 x 90 mm	150 180
Hydraulically activated	H
Non-releasing	U
No adjustment to accommodate friction block wear	K
Max. clamping force 140 kN (HW 150) Max. clamping force 200 kN (HW 180)	140 200

### Example for ordering

Brake Caliper HW 150 HUK,  
max. clamping force 140 kN:

HW 150 HUK - 140

## Technical Data

### Brake Caliper HW 150 HUK

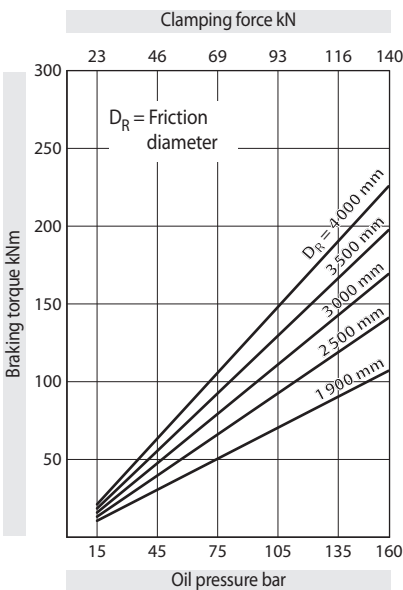

The braking torques shown in the diagram are based on a theoretical friction coefficient of 0,4.

Oil pressure: min. 15 bar  
max. 160 bar

Oil volume: max. 133 cm<sup>3</sup>

Weight: ca. 65 kg

### Brake Caliper HW 180 HUK

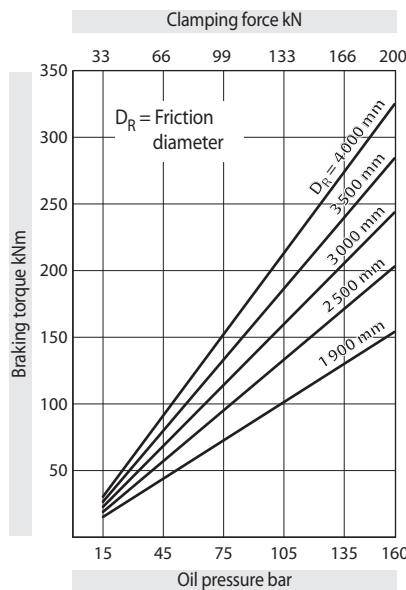

The braking torques shown in the diagram are based on a theoretical friction coefficient of 0,4.

Oil pressure: min. 15 bar  
max. 160 bar

Oil volume: max. 190 cm<sup>3</sup>

Weight: ca. 65 kg

## Other features

- High safety against leakage
- Easy change of friction blocks
- Painted with surface coating class C4-L according to ISO 12944
- For brake disc thickness  $W = 30$  mm; larger brake disc thicknesses can be achieved with the use of a spacer installed by the customer

## Accessories

- Optional painting with surface coating class C4-H or C5M-H (offshore) according to ISO 12944

# Brake Calipers HW 150 HUK and HW 180 HUK

hydraulically activated – non-releasing  
as yaw brake in wind turbines

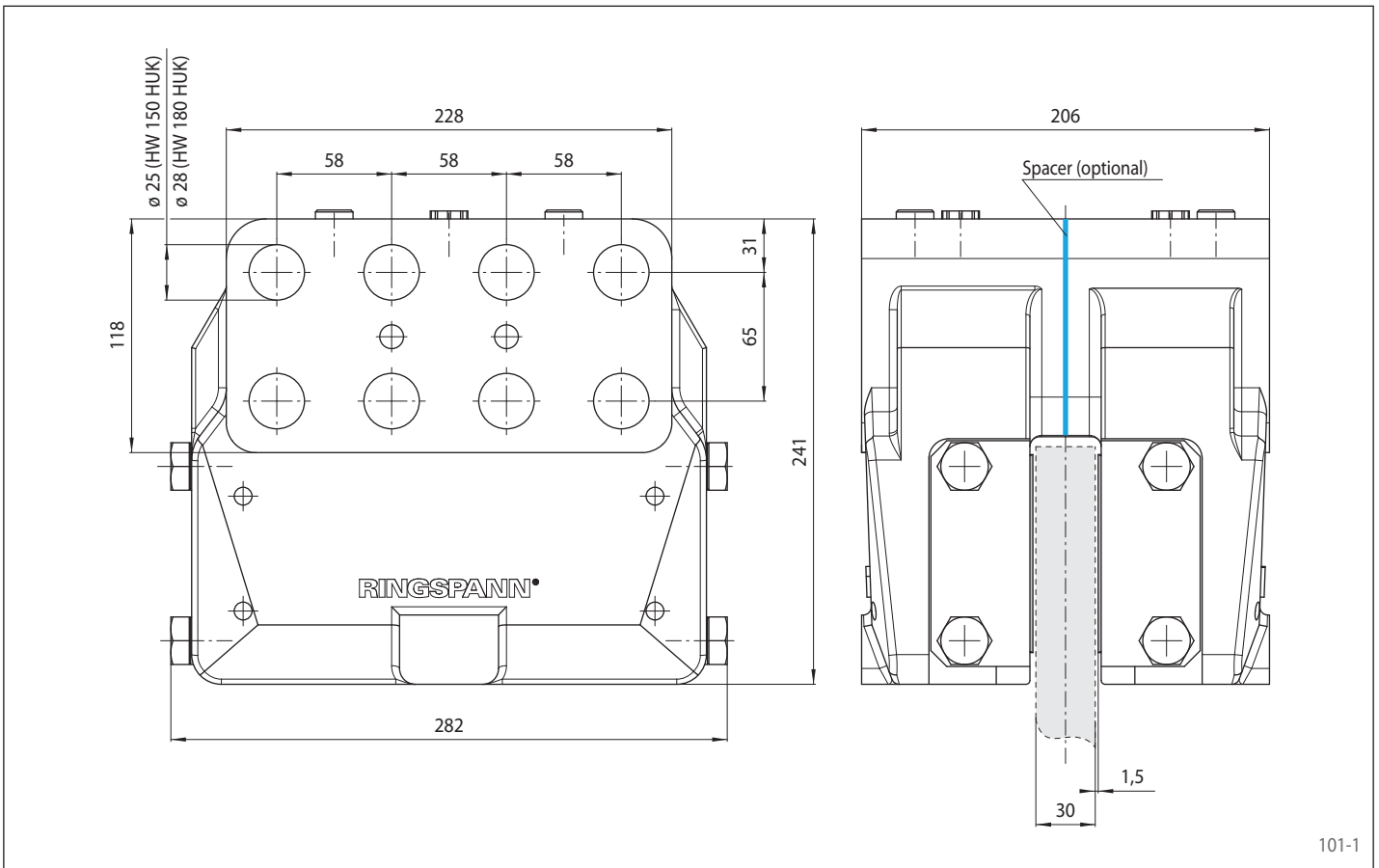

101-1

## Mounting

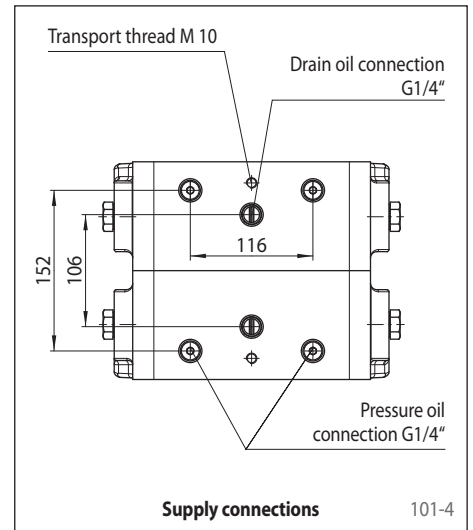
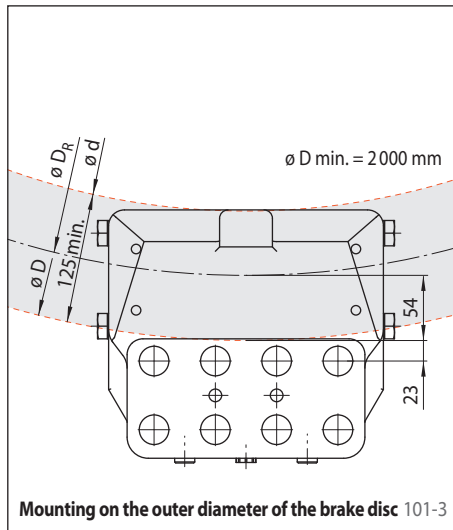
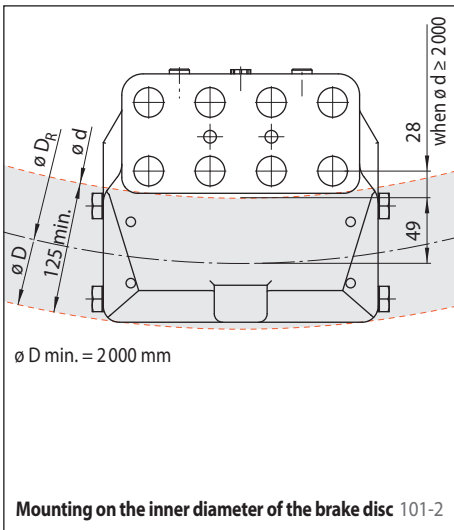

## Calculation of the friction diameter

Mounting on the inner diameter of the brake disc:

$$D_R = d + (2 \cdot 49 \text{ mm})$$

(when  $d \geq 2000 \text{ mm}$ )

Mounting on the outer diameter of the brake disc:

$$D_R = D - (2 \cdot 54 \text{ mm})$$

## Calculation of the braking torque

HW 150 HUK:

$$M_B = \frac{D_R}{1,132} \cdot p \cdot \mu$$

HW 180 HUK:

$$M_B = \frac{D_R}{0,786} \cdot p \cdot \mu$$

## Formula symbols

- $M_B$  = Braking torque [Nm]
- $D$  = Outer diameter brake disc [mm]
- $d$  = Inner diameter brake disc [mm]
- $D_R$  = Friction diameter [mm]
- $p$  = Oil pressure [bar]
- $\mu$  = Friction coefficient

# Brake Caliper HW 040 HFA

hydraulically activated – spring released

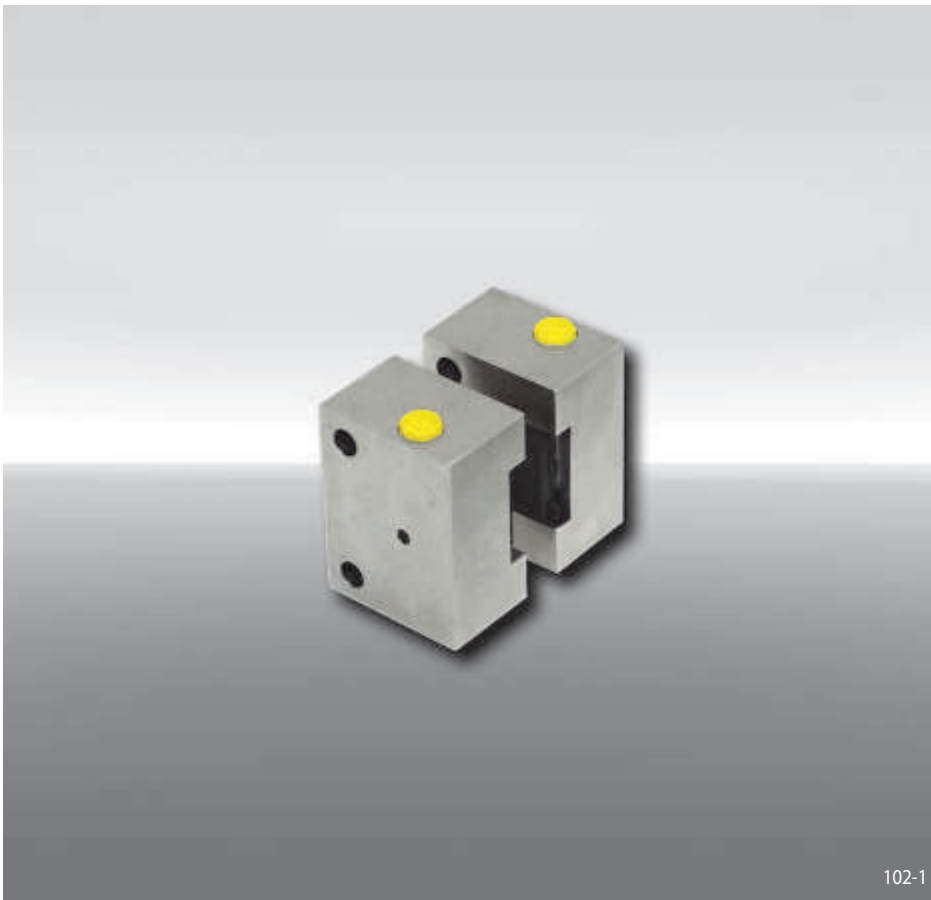

## Features

Features	Code
Brake Caliper	H
Standard	W
With piston diameter 40 mm	040
Hydraulically activated	H
Spring released	F
Automatic adjustment to accommodate friction block wear	A
Max. clamping force 11 kN	011

## Example for ordering

Brake Caliper HW 040 HFA,  
max. clamping force 11 kN:

HW 040 HFA - 011

## Technical Data

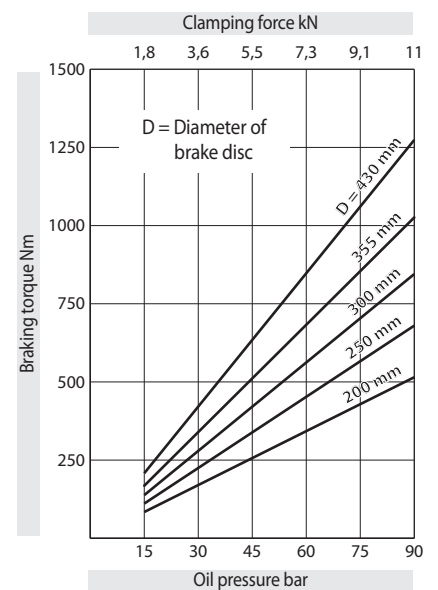

The braking torques shown in the diagram are based on a theoretical friction coefficient of 0,3.

- Oil pressure: min. 5 bar  
max. 90 bar
- Oil volume: max. 20 cm<sup>3</sup>
- Weight: 5,5 kg

## Other features

- The thickness of the customer connecting part results from the thickness of the brake disc W plus 3 mm

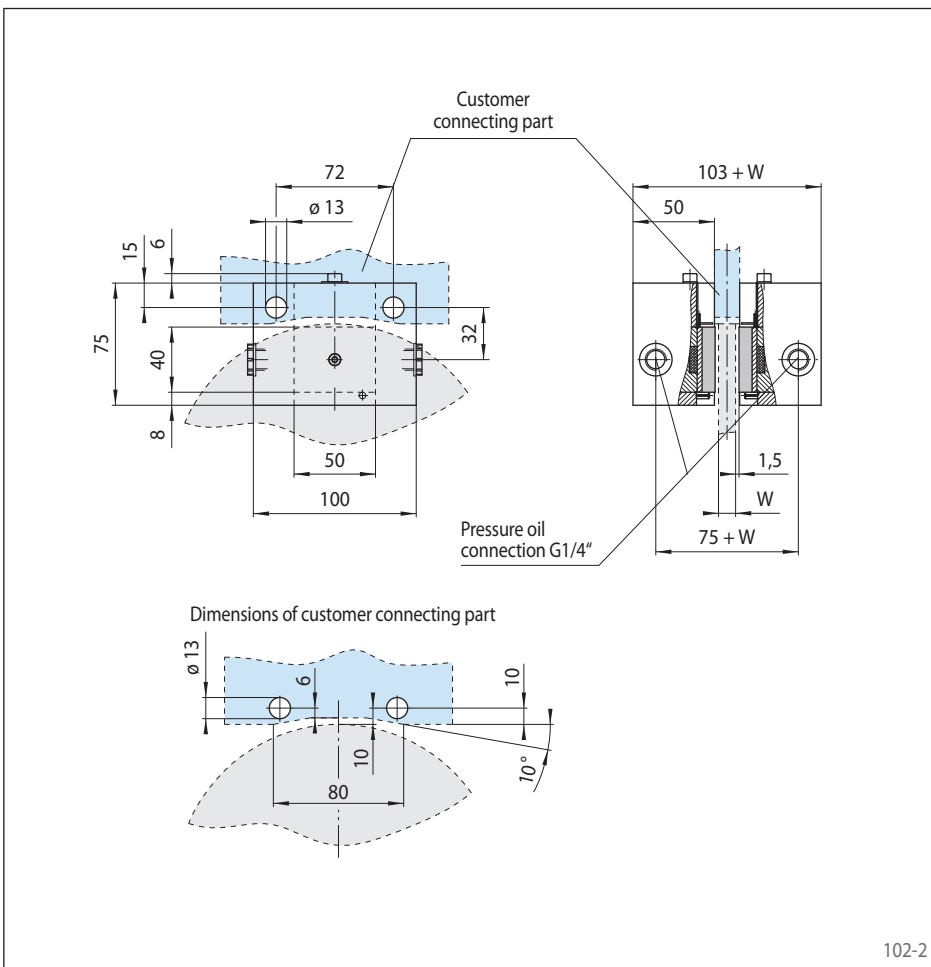

102-1

102-2

# Brake Caliper HW 063 HFA

hydraulically activated – spring released

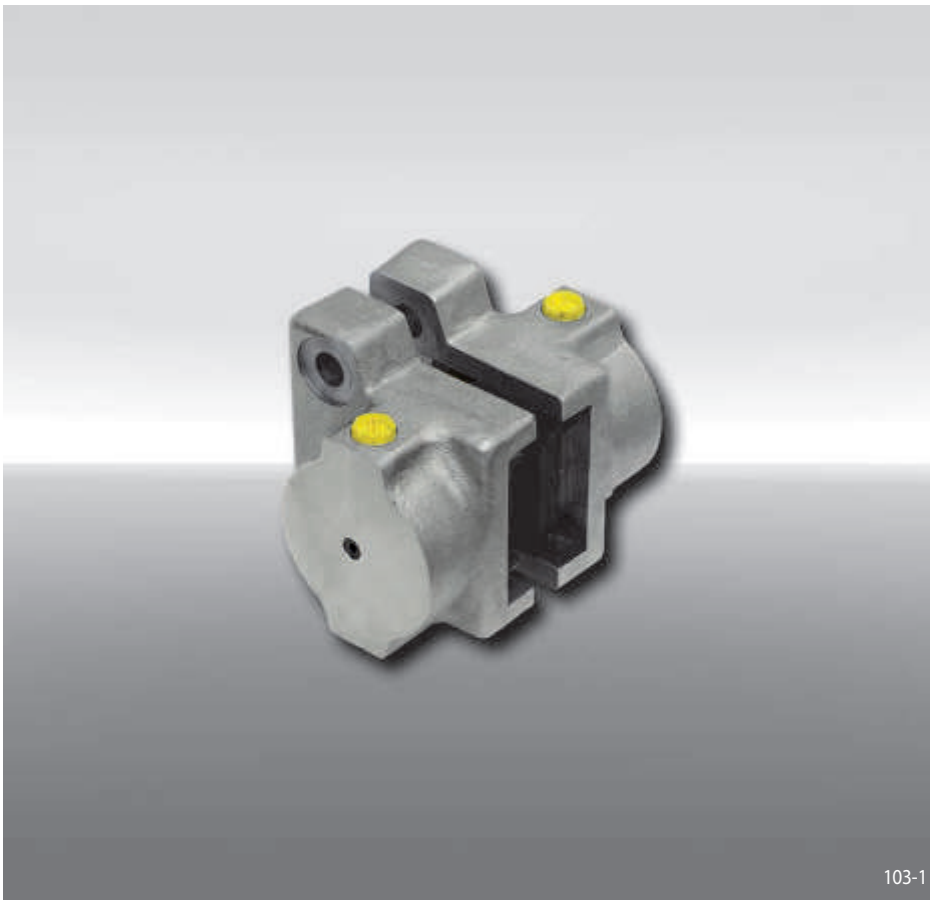

## Features

Features	Code
Brake Caliper	H
Standard	W
With piston diameter 63 mm	063
Hydraulically activated	H
Spring released	F
Automatic adjustment to accommodate friction block wear	A
Max. clamping force 28 kN	028

## Example for ordering

Brake Caliper HW 063 HFA,  
max. clamping force 28 kN:

HW 063 HFA - 028

## Technical Data

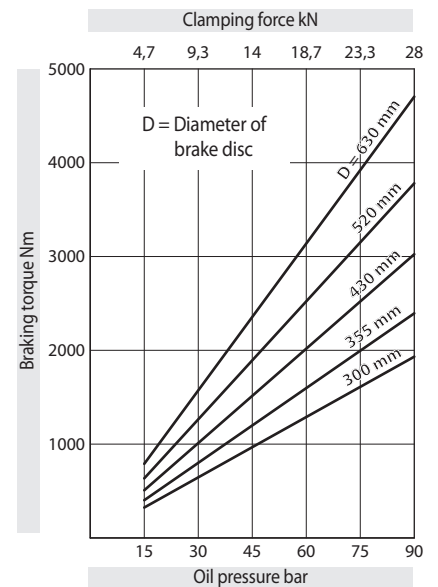
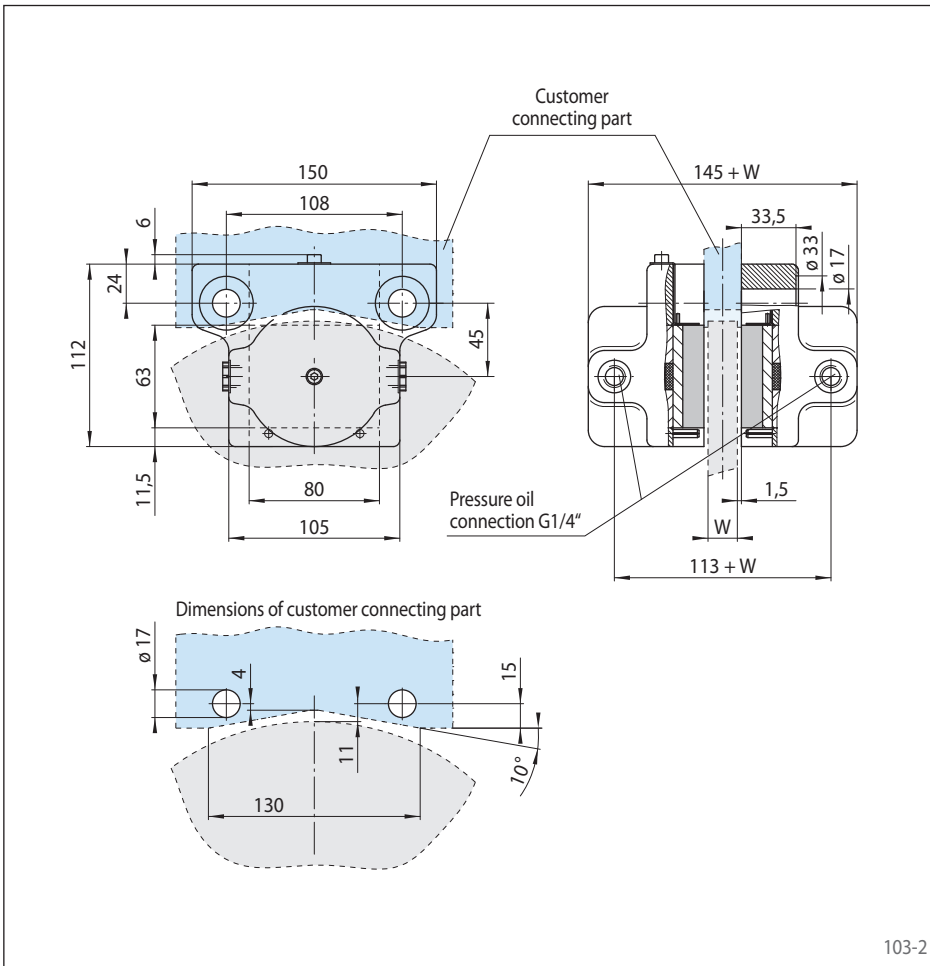

The braking torques shown in the diagram are based on a theoretical friction coefficient of 0,3.

Oil pressure: min. 5 bar  
max. 90 bar

Oil volume: max. 78 cm<sup>3</sup>

Weight: 8 kg

## Other features

- The thickness of the customer connecting part results from the thickness of the brake disc W plus 3 mm

103-1

103-2



# Brake Caliper HS 075 HFK

hydraulically activated – spring released



## Features

Features	Code
Brake Caliper	H
Floating caliper	S
With piston diameter 75 mm	075
Hydraulically activated	H
Spring released	F
No adjustment to accommodate friction block wear	K
Max. clamping force 55 kN	055

## Example for ordering

Brake Caliper HS 075 HFK,  
max. clamping force 55 kN:

HS 075 HFK - 055

## Technical Data

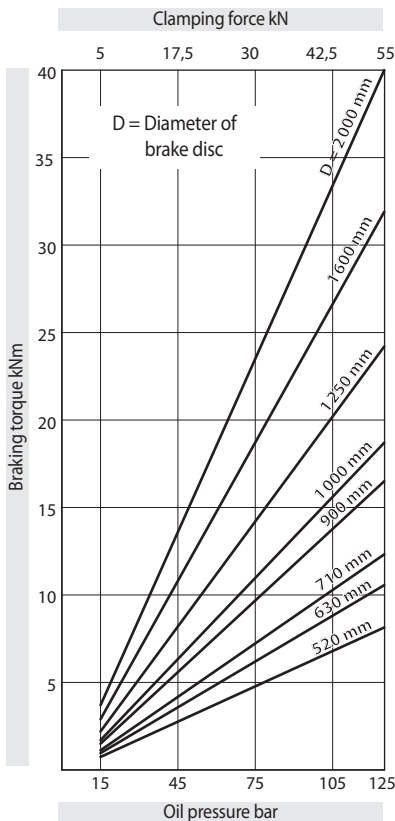

Oil pressure: min. 15 bar  
max. 125 bar

Oil volume: max. 70 cm<sup>3</sup>

Weight: ca. 80 kg

## Other features

- High safety against leakage
- Easy change of friction blocks
- Painted with surface coating class C4-L according to ISO 12944
- For brake disc thickness  $W = 20$  mm; brake disc thicknesses of up to 40 mm can be achieved with the use of a spacer installed by the customer

## Accessories

- Inductive proximity switch for "brake released" operating status
- Inductive proximity switch for brake pad wear control
- Optional painting with surface coating class C4-H or C5M-H (offshore) according to ISO 12944

The braking torques shown in the diagram are based on a theoretical friction coefficient of 0,4.

# Brake Caliper HS 075 HFK

hydraulically activated – spring released

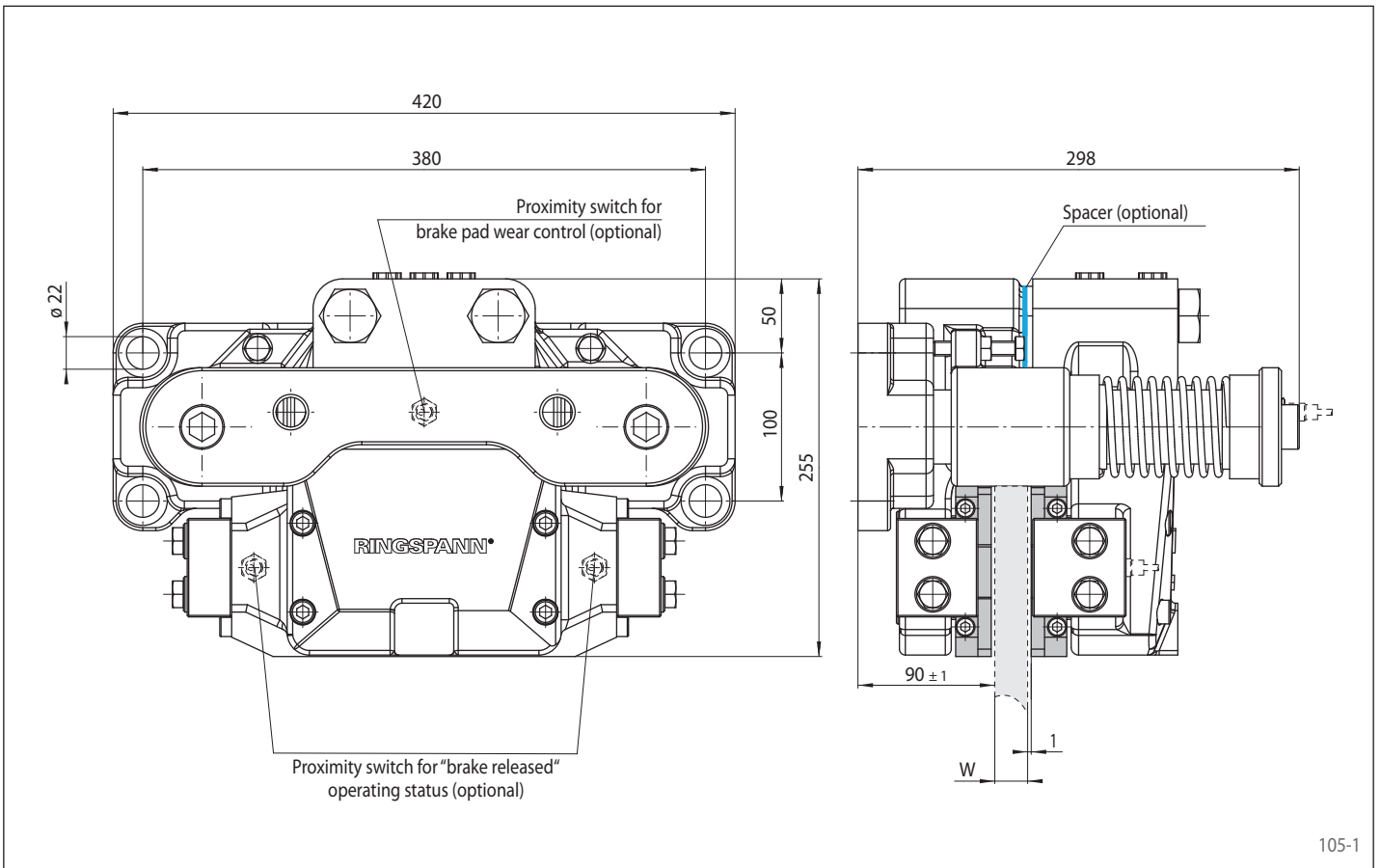

105-1

## Mounting

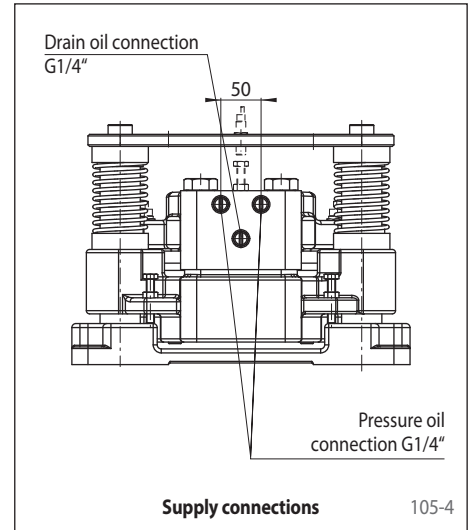
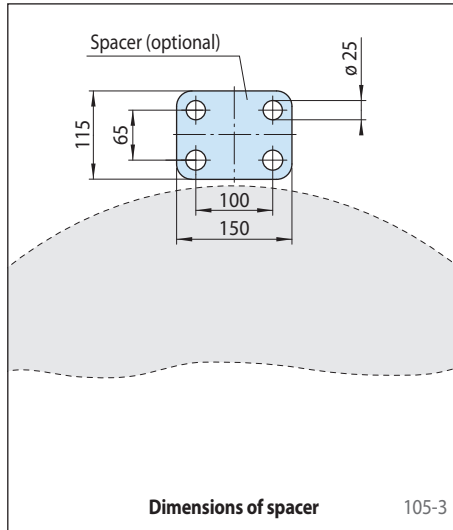
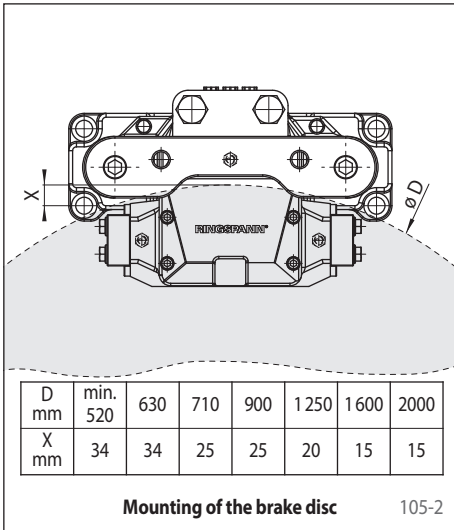

# Brake Caliper HW 075 HFK

hydraulically activated – spring released

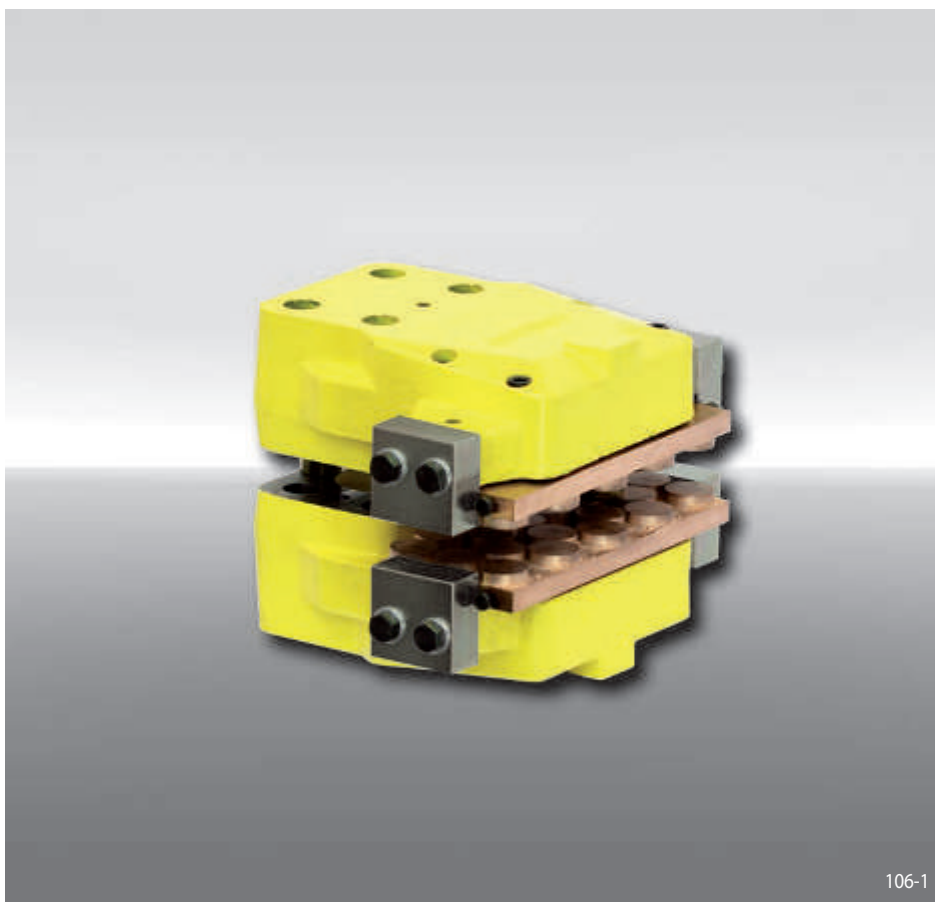

## Features

Features	Code
Brake Caliper	H
Standard	W
With piston diameter 75 mm	075
Hydraulically activated	H
Spring released	F
No adjustment to accommodate friction block wear	K
Max. clamping force 55 kN	055

## Example for ordering

Brake Caliper HW 075 HFK,  
max. clamping force 55 kN:

HW 075 HFK - 055

## Technical Data

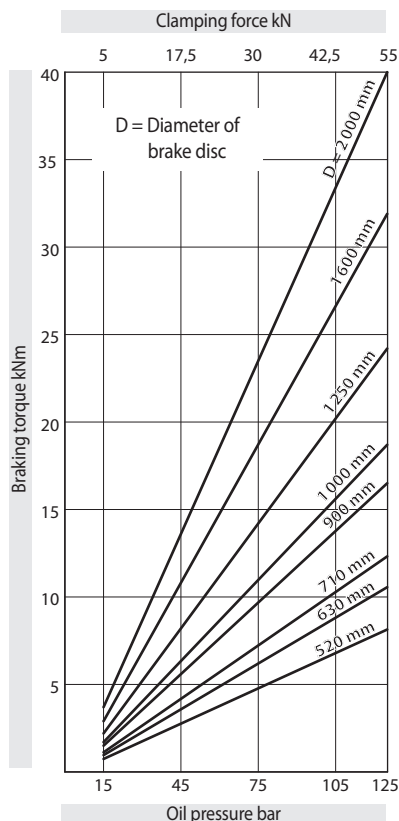

Oil pressure: min. 15 bar  
max. 125 bar

Oil volume: max. 75 cm<sup>3</sup>

Weight: ca. 60 kg

## Other features

- High safety against leakage
- Easy change of friction blocks
- Painted with surface coating class C4-L according to ISO 12944
- The thickness of the customer connecting part results from the thickness of the brake disc W plus 3 mm

## Accessories

- Inductive proximity switch for "brake released" operating status
- Optional painting with surface coating class C4-H or C5M-H (offshore) according to ISO 12944

The braking torques shown in the diagram are based on a theoretical friction coefficient of 0,4.

# Brake Caliper HW 075 HFK

hydraulically activated – spring released

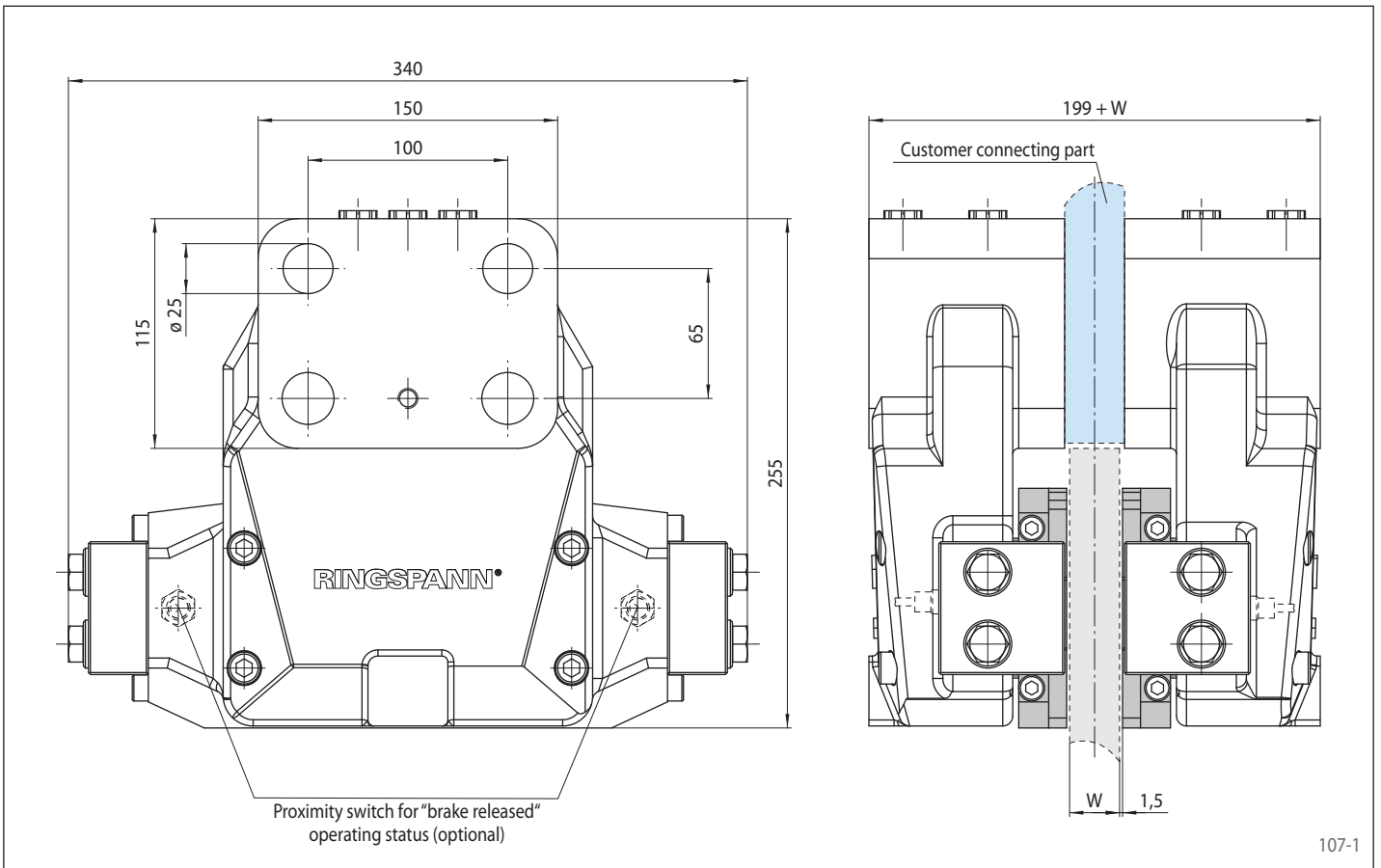

## Mounting

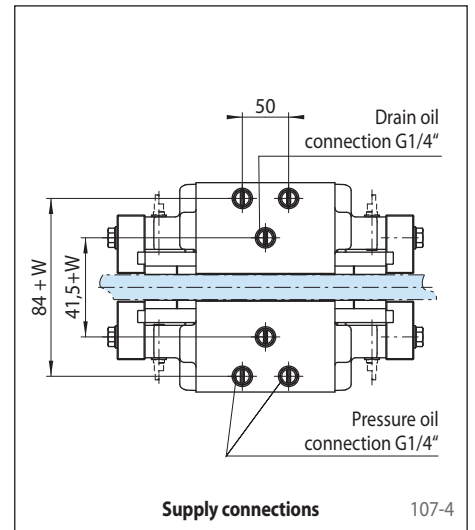
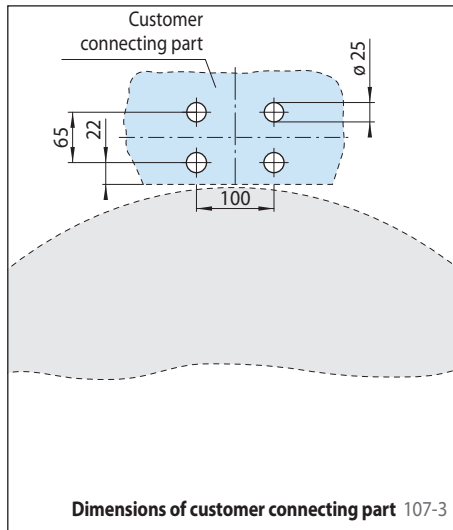
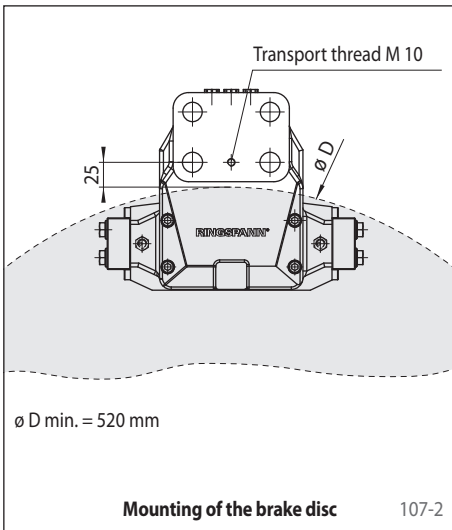

# Brake Caliper HW 100 HFA

hydraulically activated – spring released



## Features

Features	Code
Brake Caliper	H
Standard	W
With piston diameter 100 mm	100
Hydraulically activated	H
Spring released	F
Automatic adjustment to accommodate friction block wear	A
Max. clamping force 70 kN	070

## Example for ordering

Brake Caliper HW 100 HFA,  
max. clamping force 70 kN:

HW 100 HFA - 070

## Technical Data

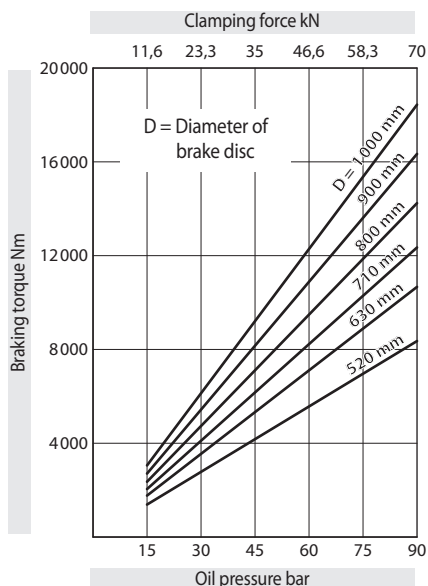

The braking torques shown in the diagram are based on a theoretical friction coefficient of 0,3.

Oil pressure: min. 5 bar  
max. 90 bar

Oil volume: max. 298 cm<sup>3</sup>

Weight: 30 kg

## Other features

- The thickness of the customer connecting part results from the thickness of the brake disc W plus 3 mm

# Brake Caliper HW 100 HFA

hydraulically activated – spring released

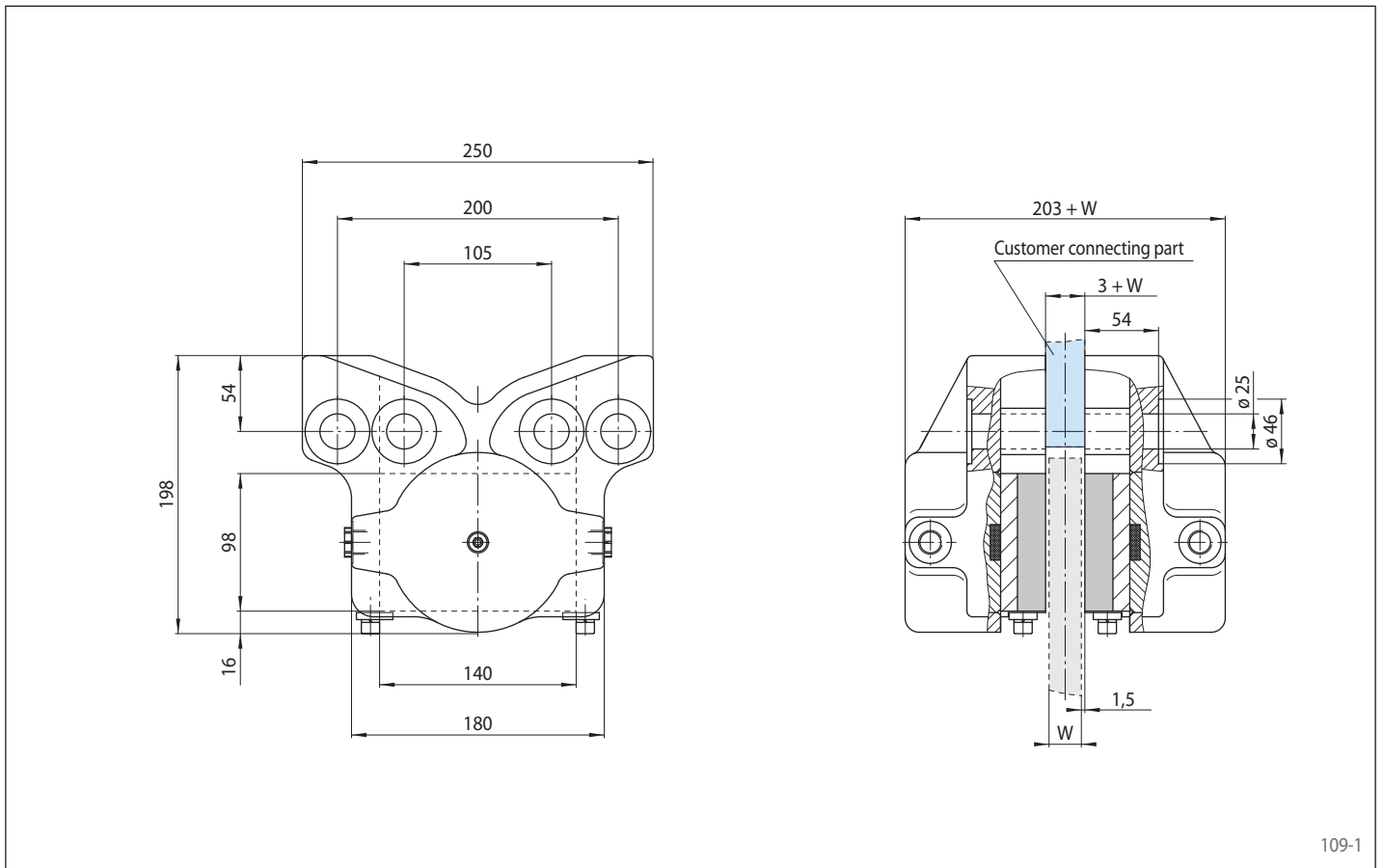

109-1

## Mounting

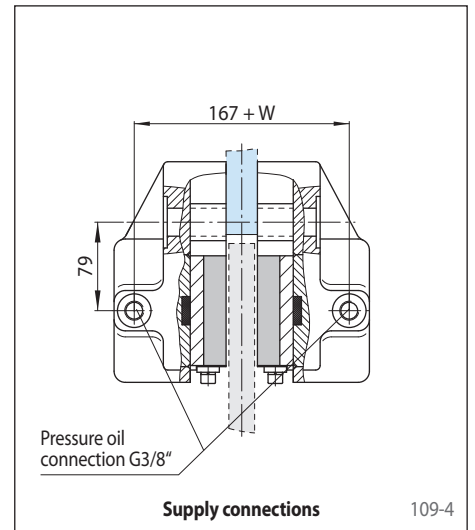
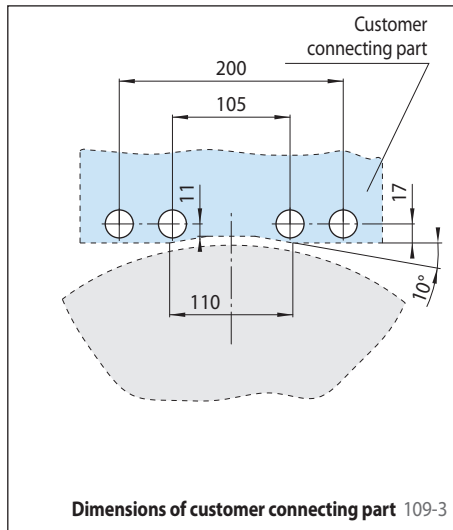
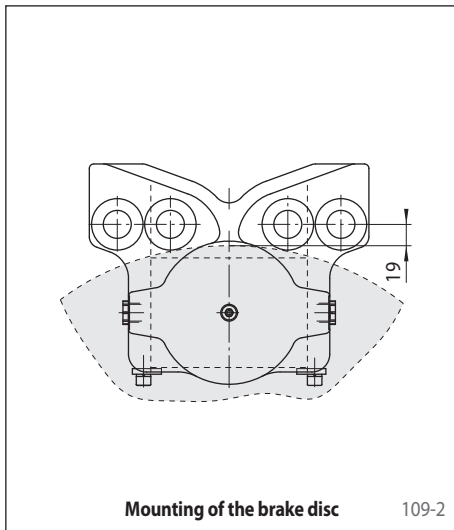



# Brake Caliper HS 120 HFK

hydraulically activated – spring released  
for wind turbines or conveyor systems

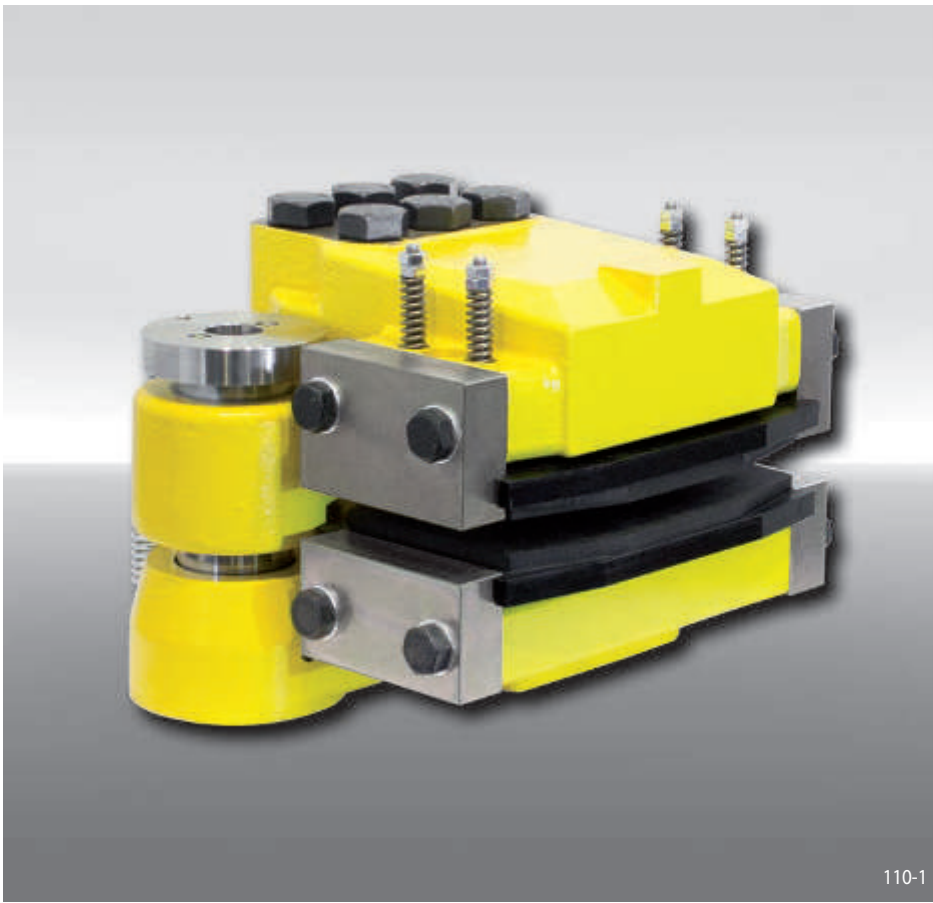

## Features

Features	Code
Brake Caliper	H
Floating caliper	S
With piston diameter 120 mm	120
Hydraulically activated	H
Spring released	F
No adjustment to accommodate friction block wear	K
Max. clamping force 130 kN	130

## Example for ordering

Brake Caliper HS 120 HFK,  
max. clamping force 130 kN:

HS 120 HFK - 130

## Technical Data

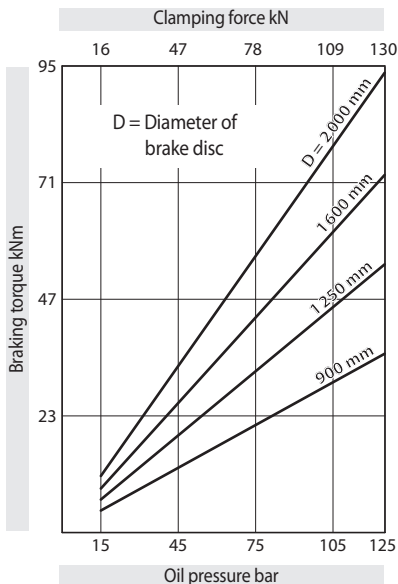

The braking torques shown in the diagram are based on a theoretical friction coefficient of 0,4.

Oil pressure: min. 15 bar  
max. 125 bar

Oil volume: max. 203 cm<sup>3</sup>

Weight: ca. 195 kg

## Other features

- High safety against leakage
- Easy change of friction blocks
- Painted with surface coating class C4-L according to ISO 12944
- For brake disc thickness  $W = 20$  mm; brake disc thicknesses of up to 40 mm can be achieved with the use of a spacer installed by the customer

## Accessories

- Inductive proximity switch for "brake released" operating status
- Inductive proximity switch for brake pad wear control
- Optional painting with surface coating class C4-H or C5M-H (offshore) according to ISO 12944

# Brake Caliper HS 120 HFK

hydraulically activated – spring released  
for wind turbines or conveyor systems

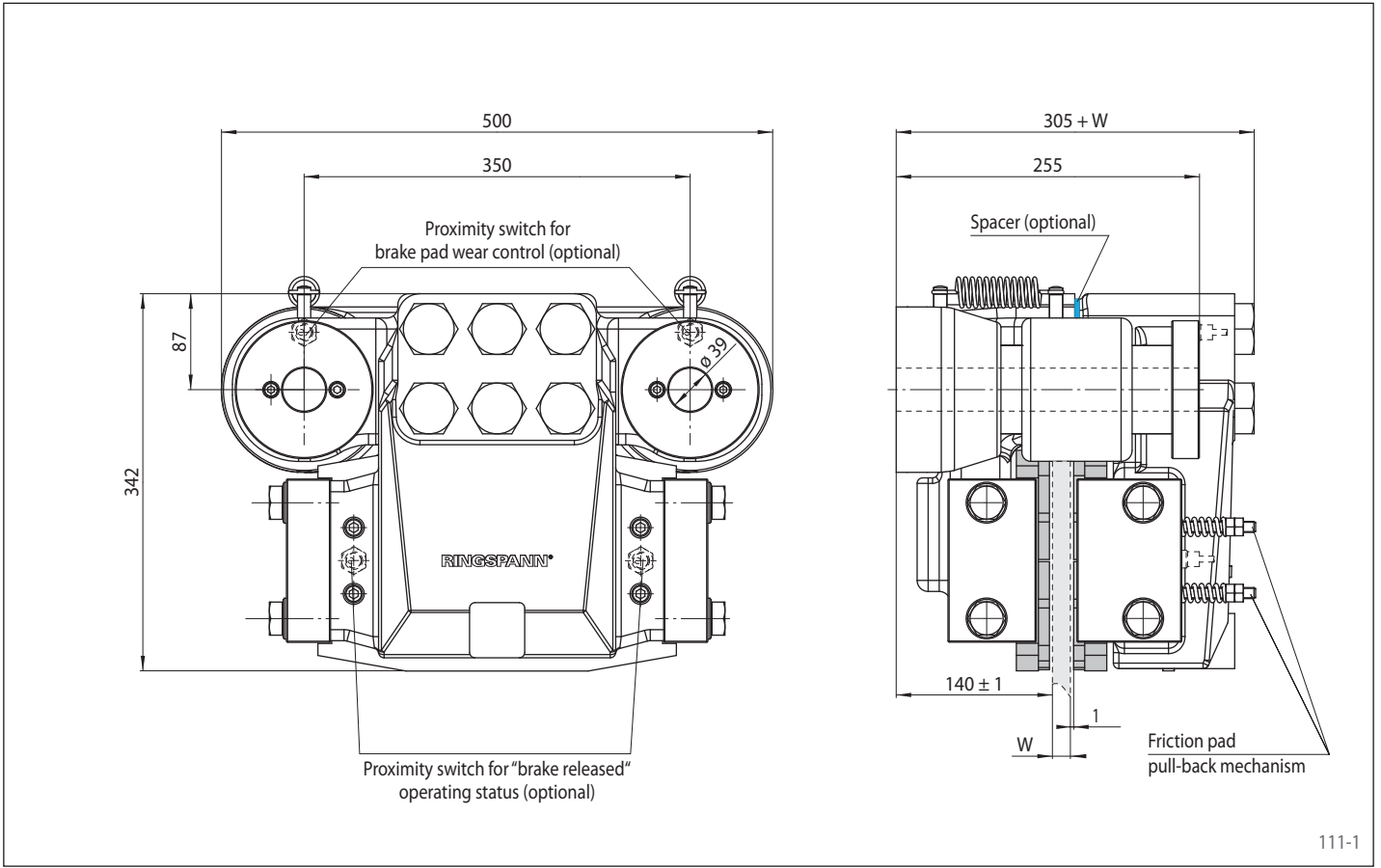

111-1

## Mounting

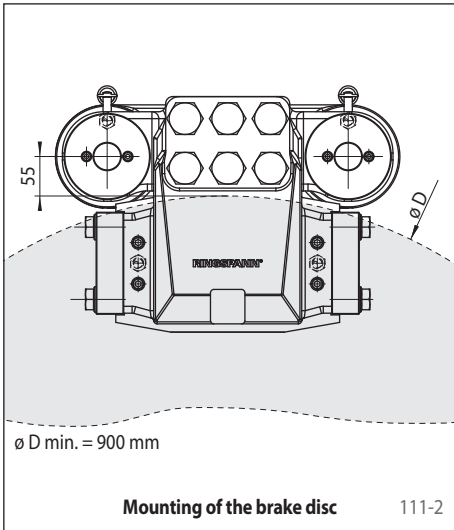

Mounting of the brake disc

111-2

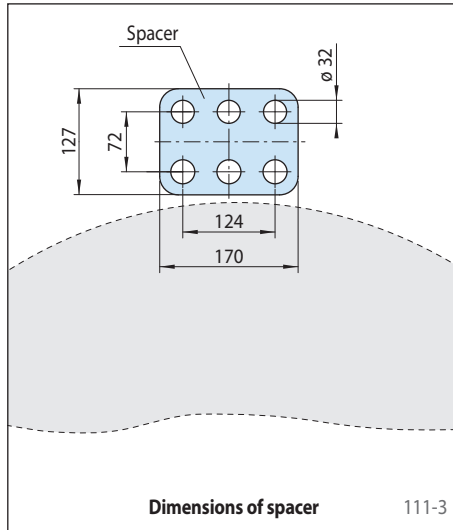

Dimensions of spacer

111-3

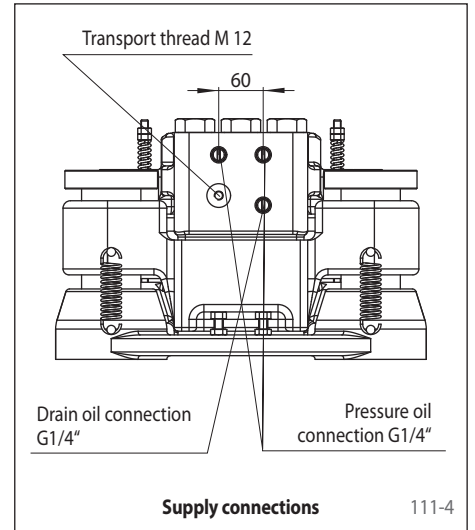

Supply connections

111-4

# Brake Caliper HW 120 HFK

hydraulically activated – spring released

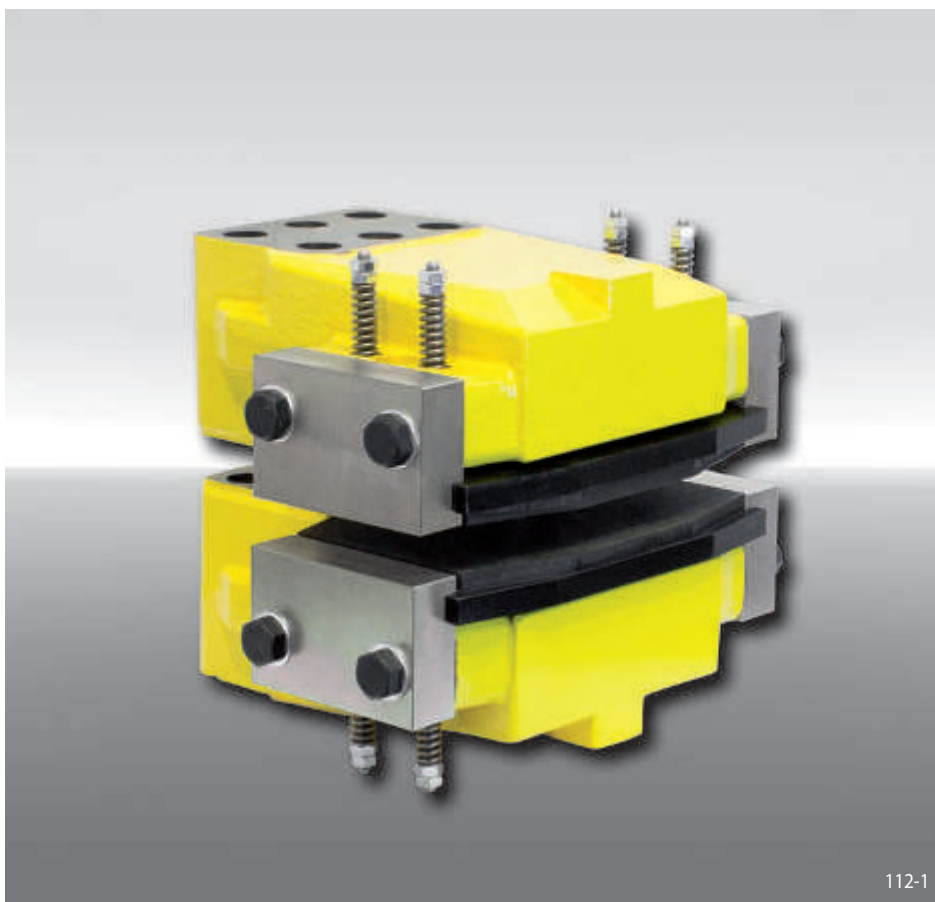

## Features

Features	Code
Brake Caliper	H
Standard	W
With piston diameter 120 mm	120
Hydraulically activated	H
Spring released	F
No adjustment to accommodate friction block wear	K
Max. clamping force 130 kN	130

## Example for ordering

Brake Caliper HW 120 HFK,  
max. clamping force 130 kN:

HW 120 HFK - 130

## Technical Data

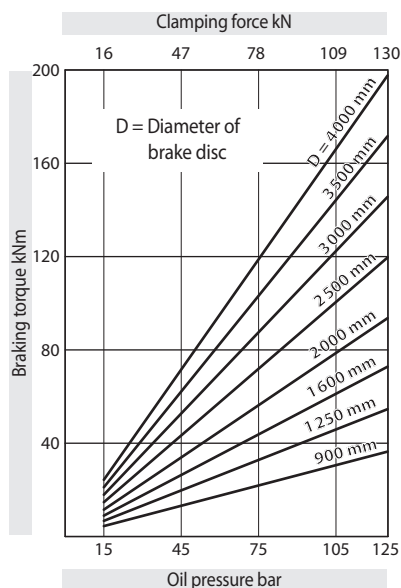

The braking torques shown in the diagram are based on a theoretical friction coefficient of 0,4.

Oil pressure: min. 15 bar  
max. 125 bar

Oil volume: max. 214 cm<sup>3</sup>

Weight: ca. 146 kg

## Other features

- High safety against leakage
- Easy change of friction blocks
- Painted with surface coating class C4-L according to ISO 12944
- The thickness of the customer connecting part results from the thickness of the brake disc W plus 3 mm

## Accessories

- Inductive proximity switch for "brake released" operating status
- Optional painting with surface coating class C4-H or C5M-H (offshore) according to ISO 12944

# Brake Caliper HW 120 HFK

hydraulically activated – spring released

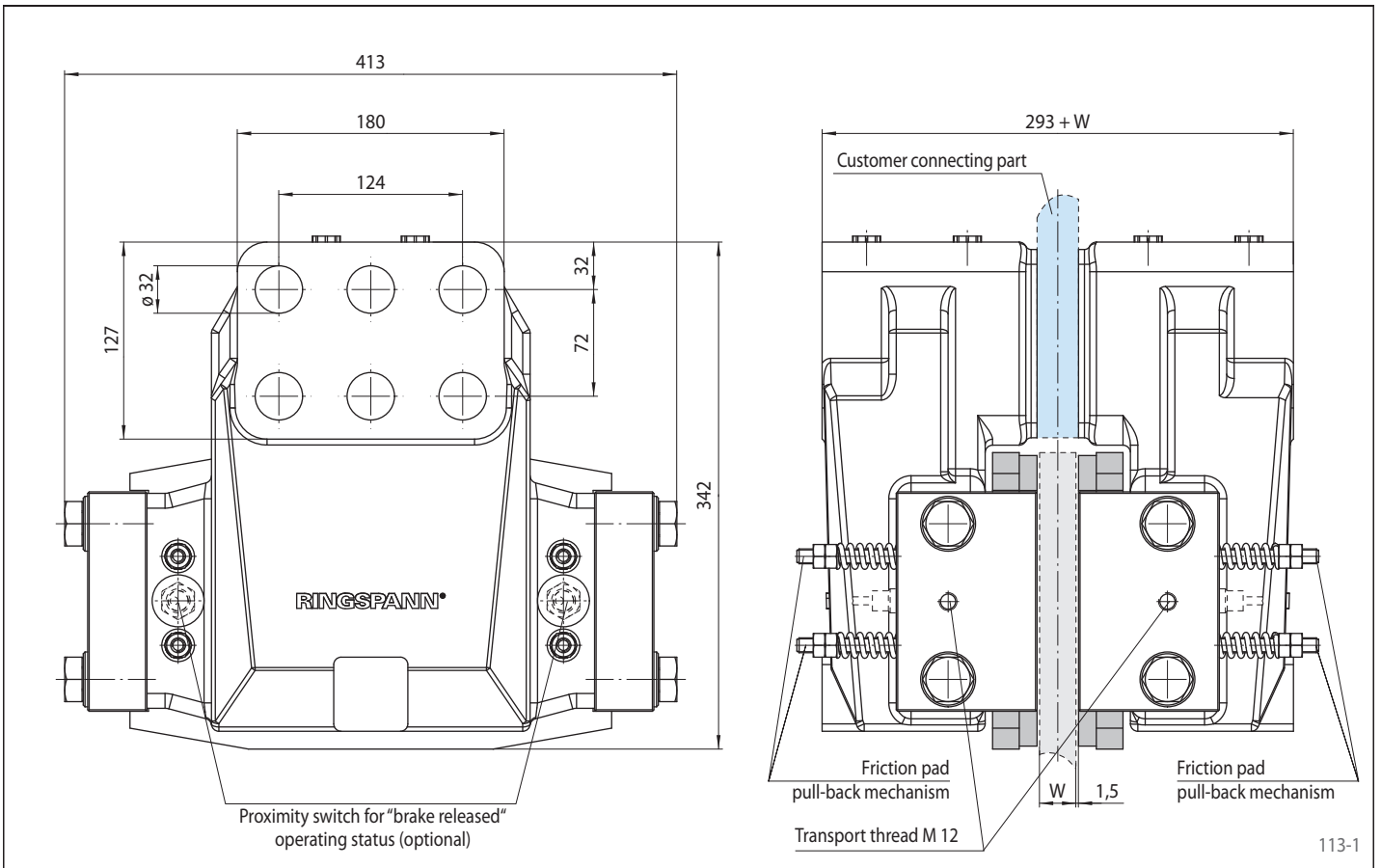

## Mounting

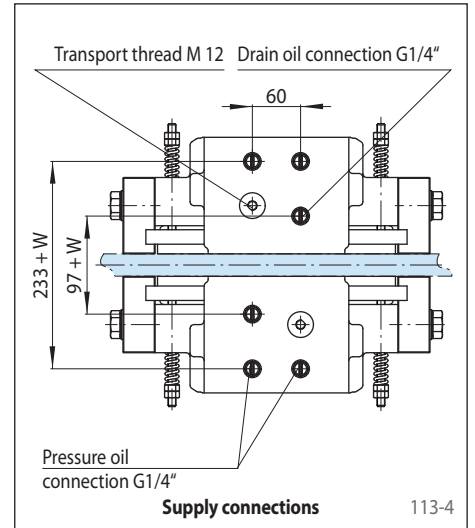
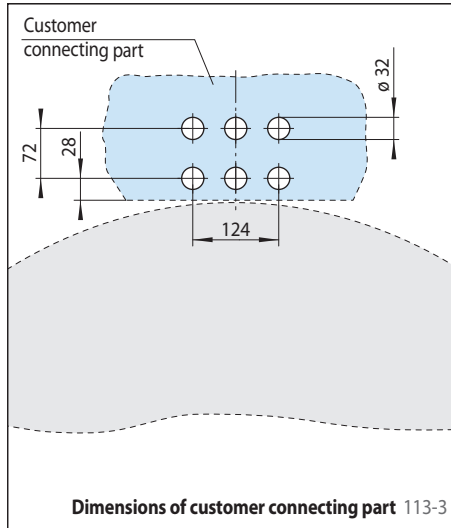
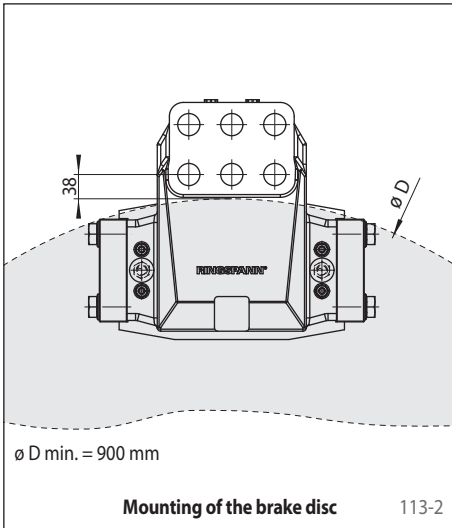

# Brake Calipers HW 150 HFA and HW 180 HFA

hydraulically activated – spring released

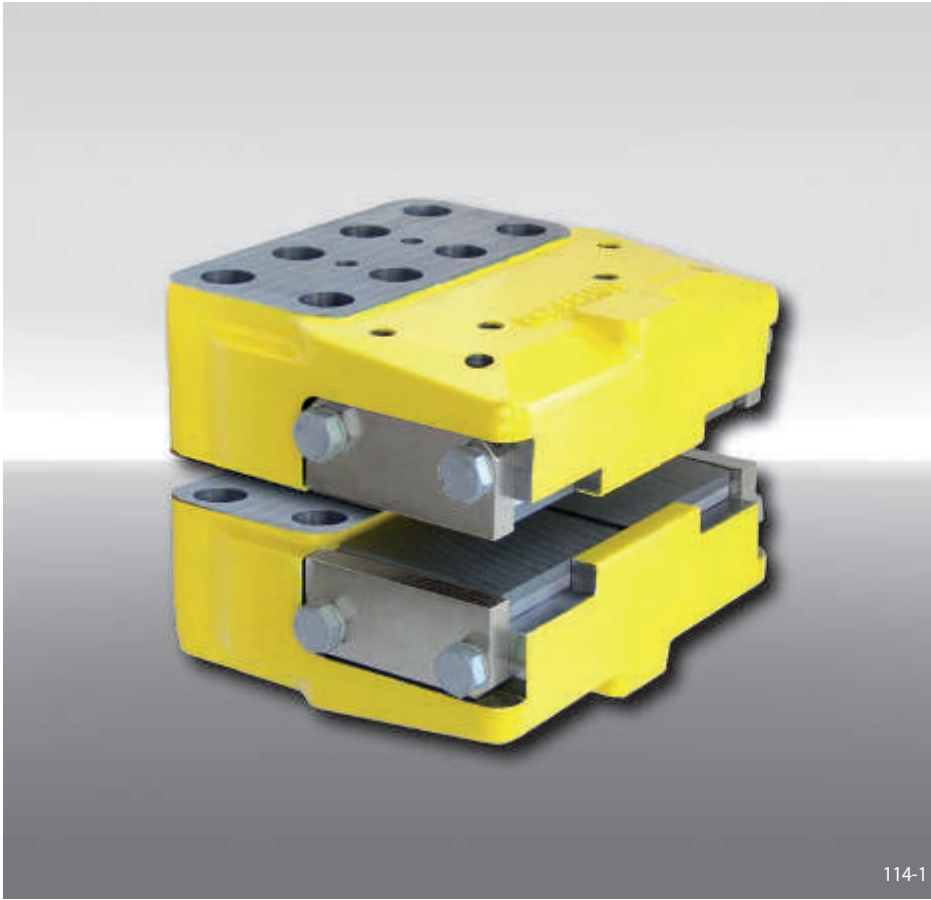

## Features

Features	Code
Brake Caliper	H
Standard	W
With piston diameter 2 x 75 mm or piston diameter 2 x 90 mm	150 180
Hydraulically activated	H
Spring released	F
Automatic adjustment to accommodate friction block wear	A
Max. clamping force 140 kN (HW 150)	140
Max. clamping force 200 kN (HW 180)	200

## Example for ordering

Brake Caliper HW 150 HFA,  
max. clamping force 140 kN:

HW 150 HFA - 140

## Technical Data

### Brake Caliper HW 150 HFA

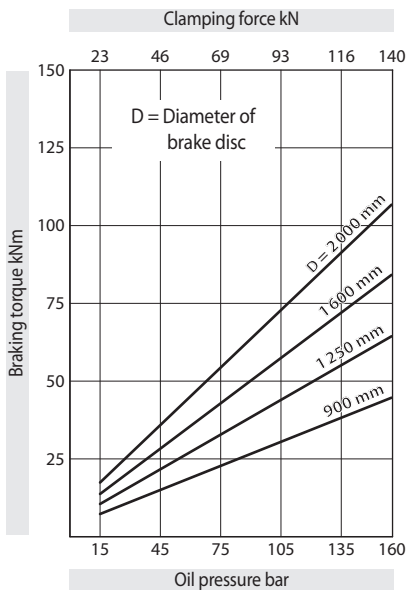

The braking torques shown in the diagram are based on a theoretical friction coefficient of 0,4.

Oil pressure: min. 15 bar  
max. 160 bar

Oil volume: max. 265 cm<sup>3</sup>

Weight: ca. 65 kg

### Brake Caliper HW 180 HFA

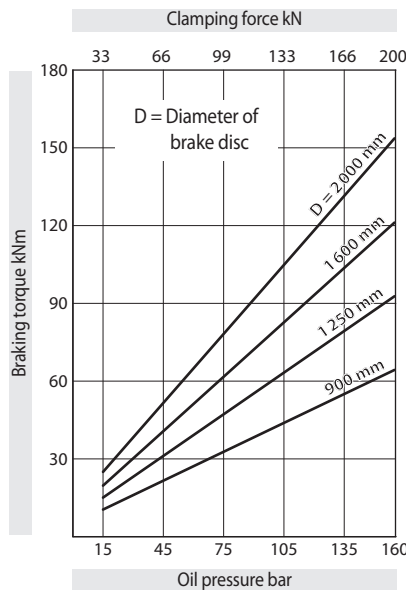

The braking torques shown in the diagram are based on a theoretical friction coefficient of 0,4.

Oil pressure: min. 15 bar  
max. 160 bar

Oil volume: max. 381 cm<sup>3</sup>

Weight: ca. 65 kg

## Other features

- High safety against leakage
- Painted with surface coating class C4-L according to ISO 12944
- The thickness of the customer connecting part results from the thickness of the brake disc W

## Accessories

- Optional painting with surface coating class C4-H or C5M-H (offshore) according to ISO 12944

# Brake Calipers HW 150 HFA and HW 180 HFA

hydraulically activated – spring released

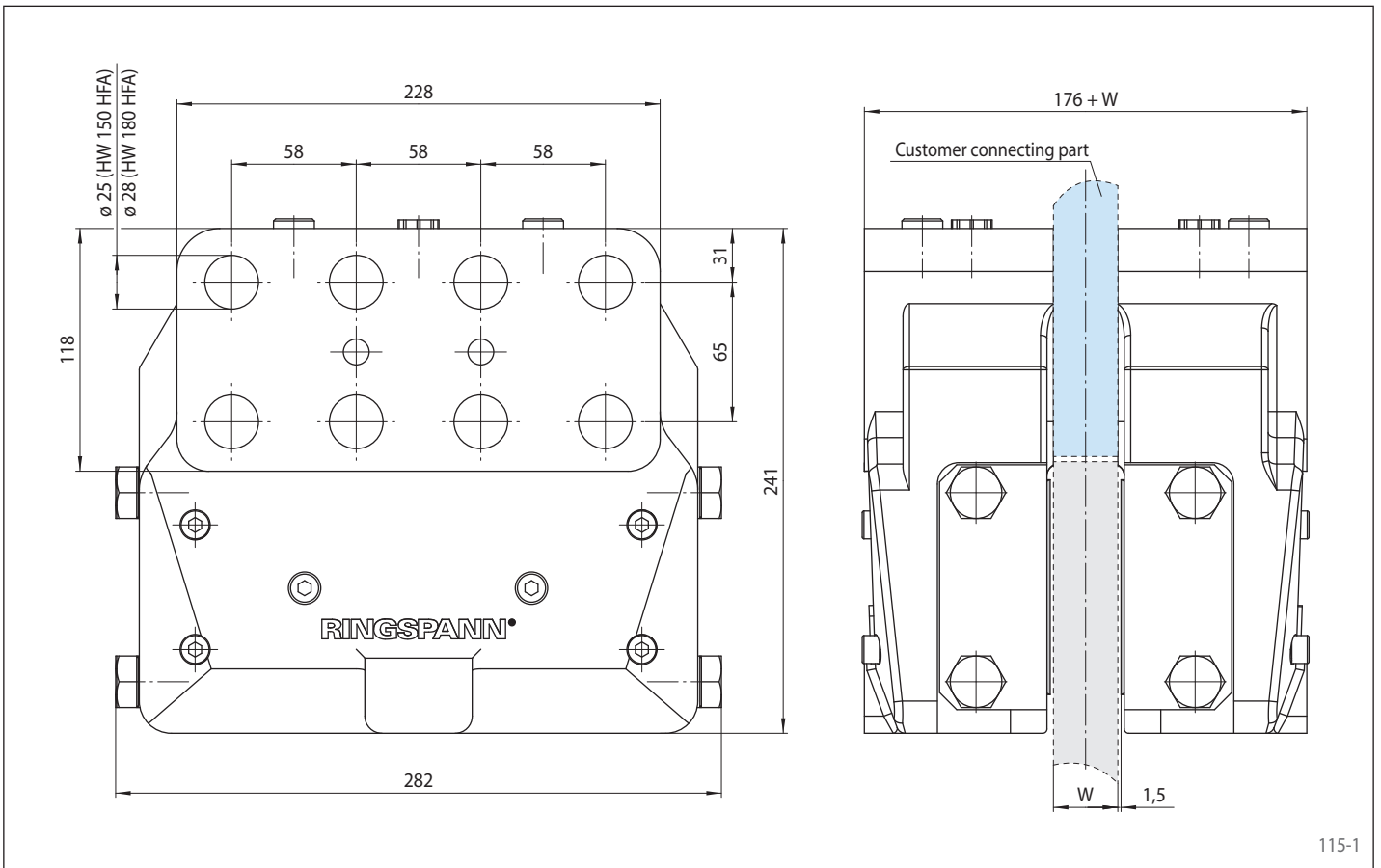

115-1

## Mounting

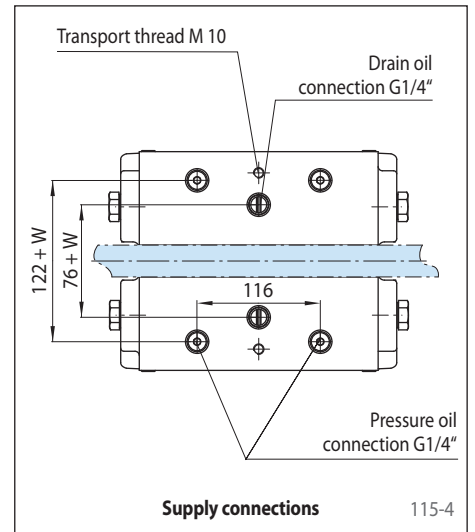
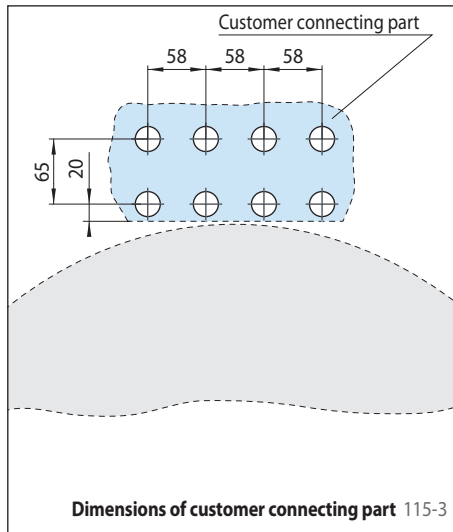
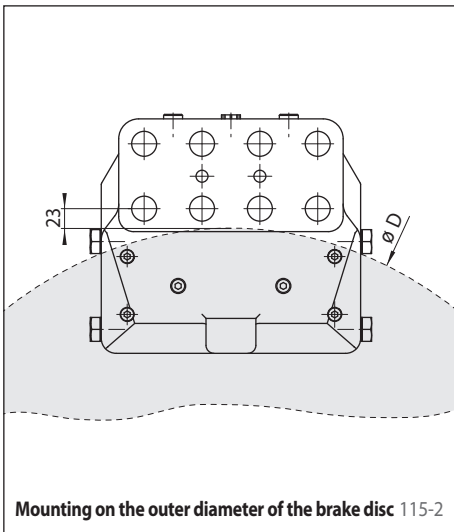





Features	Code
Brake Disc	B
Form	F B S
Size of Brake Discs according to table	0125 to 1000
Thickness of brake disc (Standard)	12 25
Bore diameter according to table	014 to 220
Form pre drilled, finished bore without keyway, finished bore with keyway	V F B

### Example for ordering

Brake Disc BF with a size of Brake Disc 200 mm, thickness of brake disc 12,5 mm and bore diameter 40 mm in Form F:

BF 0200/12 - 040 F

## Technical Data

Size	Thickness of brake disc	Max. speed	Form F	Form B	Form S*		
					Clamping diameter	Inertia moment	Max. braking torque
D mm	W mm	$n_{max}$ $min^{-1}$	Inertia moment J $kgm^2$	Inertia moment J $kgm^2$	d mm	J $kgm^2$	$M_{max}$ Nm
125	12,5	14 500	0,0022	0,0023	-	-	-
150	12,5	12 100	0,0045	0,0047	-	-	-
200	12,5	9 100	0,0141	0,0146	-	-	-
250	12,5	7 300	0,0345	0,0380	-	-	-
300	12,5	6 000	0,0720	0,0800	80	0,078	950
355	12,5 / 25	5 100	0,140 / 0,270	0,162 / 0,243	-	-	-
430	12,5 / 25	4 200	0,302 / 0,596	0,352 / 0,638	90	0,305	1 500
					140	0,405	3 750
					160	0,646	6 000
520	12,5 / 25	3 500	0,646 / 1,273	0,790 / 1,380	140	0,752	3 750
					160	0,990	6 000
					200	1,431	9 500
630	25	2 900	2,780	3,130	-	-	-
710	25	2 600	4,490	5,090	-	-	-
800	25	2 300	7,240	8,420	-	-	-
900	25	2 000	11,59	13,70	-	-	-
1 000	25	1 800	17,70	21,30	-	-	-

\* Only available in thickness of brake disc W = 12,5 mm

## Features

- Optimized for use with RINGSPANN Brakes
- Cast material for best heat absorption
- Ready to install versions are available
- Variants with finished bore, keyway or shrink disc
- Disk diameter ranging from 125 mm to 1000 mm
- The Brake Disc are made from EN 1563 EN-GJS500-7 (GGG-50 after DIN 1693)
- Other sizes of Brake Discs are available on request

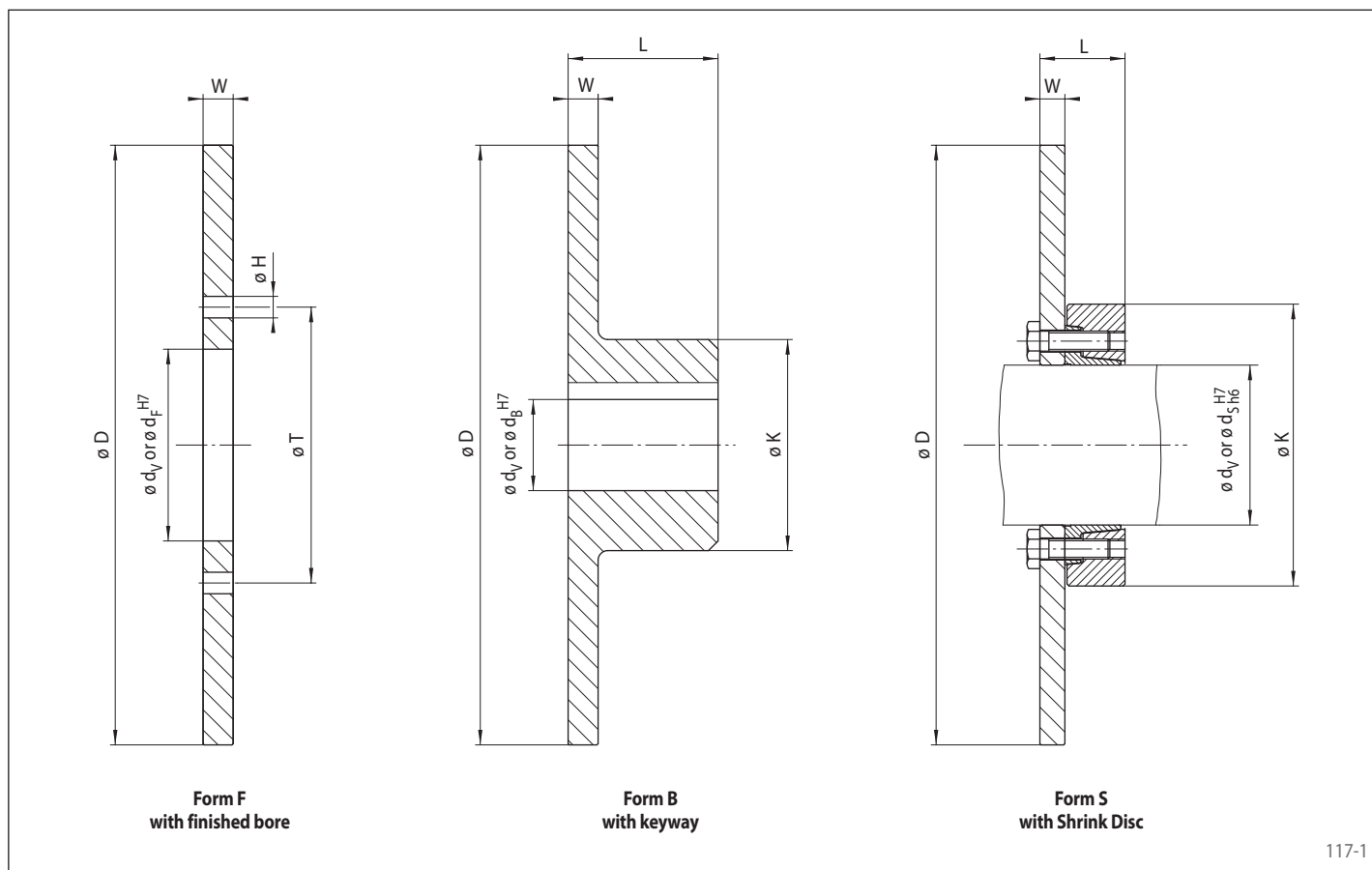

## Dimensions

Size	Thickness of brake disc	Pre drilled	Form F				Form B			Form S		
			Finished bore $d_F$	H	T	Z*	Max. finished bore $d_B^{**}$	L	K	Clamping diameter $d_S$	L***	K
D mm	W mm	$d_V$ mm	$d_F$ mm	H mm	T mm	Z*	$d_B^{**}$ mm	L mm	K mm	$d_S$ mm	L*** mm	K mm
125	12,5	-	40	9	56	4	32	37,5	50	-	-	-
150	12,5	-	50	9	66	4	40	42,5	60	-	-	-
200	12,5	-	63	11	83	8	45	52,5	65	-	-	-
250	12,5	-	80	11	100	8	70	62,5	100	-	-	-
300	12,5	-	100	14	122	8	80	72,5	120	80	46,5	141
355	12,5 / 25	-	110	14	132	10	100	82,5	145	-	-	-
430	12,5 / 25	50	125	14	147	12	115	97,5	170	90	52,5	155
										140	74,5	230
										160	84,5	290
										140	74,5	230
520	12,5 / 25	50	160	14	182	16	140	117,5	210	160	84,5	290
										160	84,5	290
										200	101,5	340
										200	101,5	340
630	25	75	-	-	-	-	155	150	250	-	-	-
710	25	95	-	-	-	-	180	165	280	-	-	-
800	25	95	-	-	-	-	200	185	320	-	-	-
900	25	120	-	-	-	-	210	205	360	-	-	-
1000	25	120	-	-	-	-	220	225	400	-	-	-

\* Z = Number of holes  $\phi H$  pitch circle  $\phi T$  • \*\* Keyway according to DIN 6885, page 1 • \*\*\* At unclamped state

## Brake Discs Form S

The following apply to the shaft:

- Yield strength  $R_e \geq 360 \text{ N/mm}^2$
- E-module ca.  $206 \text{ kN/mm}^2$

## Surfaces

Average surface roughness at the contact surfaces of the shaft  $R_a \leq 3,2 \mu\text{m}$ .

## Dimensioning

Please refer to the technical points on page 119 when dimensioning the brake disc size.

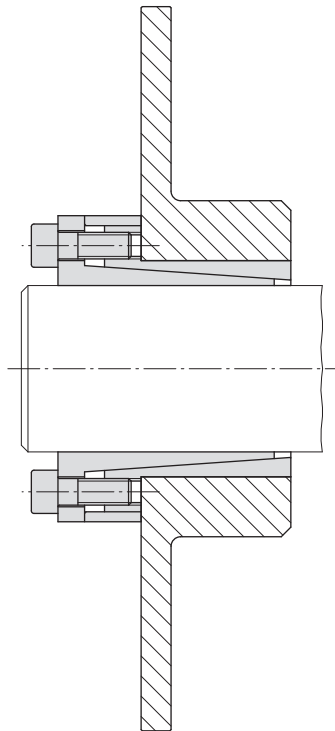

**Cone Clamping Element RLK 110  
with Brake Disc Form B**

118-1

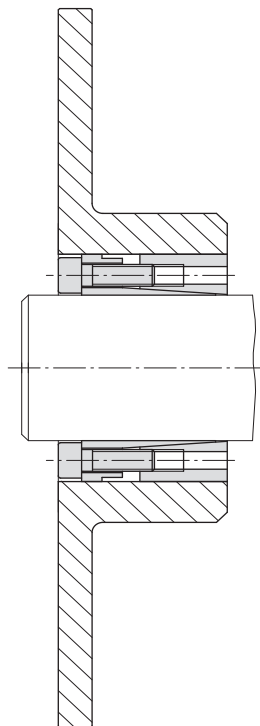

**Cone Clamping Element RLK 130  
with Brake Disc Form B**

118-2

## Verification of Heat Absorption

### Permissible Braking Action with Single Braking Operation

Extreme braking processes should be checked to ensure that the brake disc will not reach 300°C when absorbing the braking energy. The braking time in this case should not exceed 10 seconds.

The maximum energy of braking to be absorbed for brake discs made from GGG-50 is given in the table. We recommend that this additional calculation be carried out in the case of indexing operations. The absorbed energy for the deceleration of rotating masses in this case is:

$$W_B = \frac{J_{red} (n_1 - n_2)^2}{182,5}$$

Ensure that:

$$W_{BSzul} \geq W_B$$

D mm	$W_{BSzul}$ Nm
125	185 000
150	270 000
200	460 000
250	760 000
300	1 300 000
355	1 900 000
430	3 000 000
520	5 000 000
630	11 000 000
710	15 000 000
800	20 000 000
900	27 000 000
1 000	35 000 000

## Verification of Heat Dissipation

The transmissible brake power of the disc according to the diagram on this page applies to the types of braking operation described below:

$$P_{BSzul} \geq P_B$$

### Braking with low frequency $z \leq 40$ per hour

If „z“ actuations occur within one hour, then the brake power capacity required is as follows:

$$P_B = \frac{M_B (n_1 - n_2)}{6,88 \cdot 10^7} \cdot z \cdot t_B$$

### Braking with high frequency $z > 40$ per hour

For such cases we would ask you to enclose with your enquiry exact details of the time slope of speed and braking torque, as well as the completed questionnaire on page 134. We will check the design of the brake disc in respect of the heat dissipation.

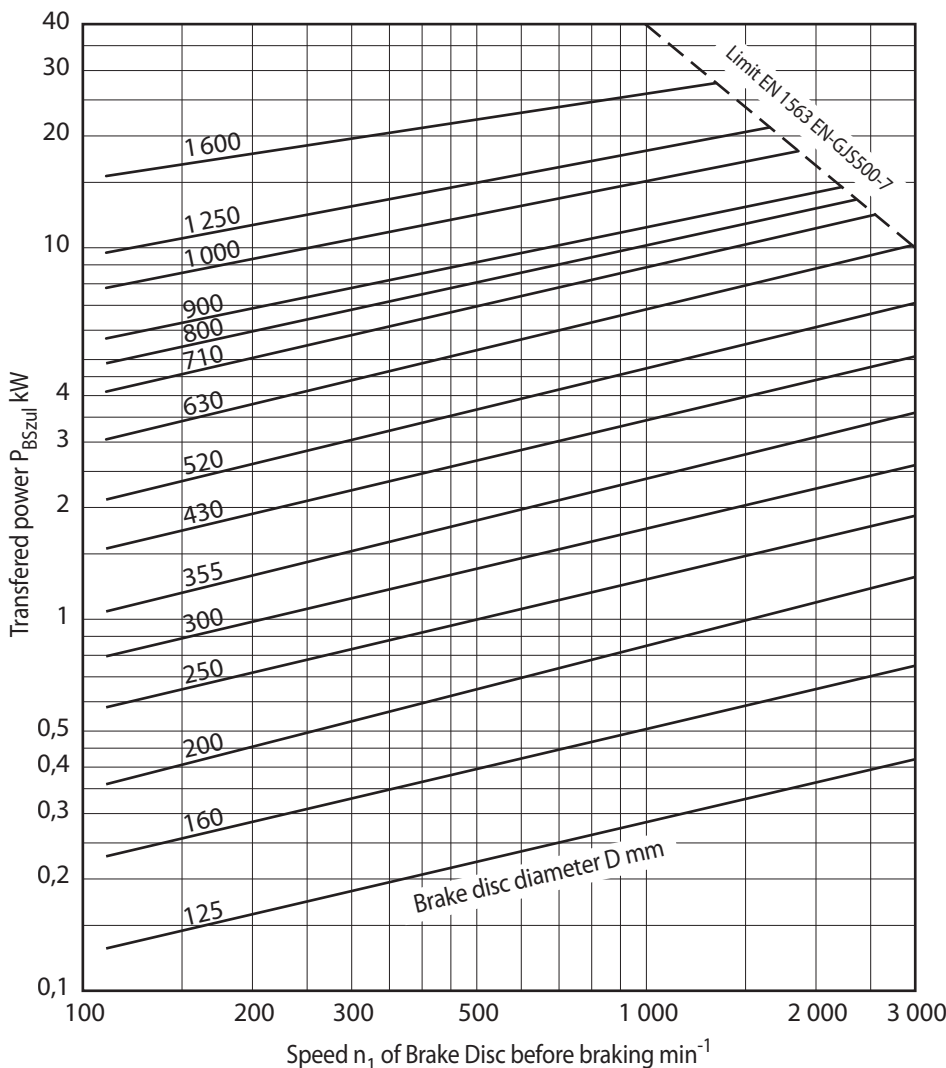

### Formula symbols

- $J_{red}$  [kg m<sup>2</sup>] Reduced inertia moment
- $M_B$  [Nm] Required braking torque
- $n_1$  [min<sup>-1</sup>] Speed before braking
- $n_2$  [min<sup>-1</sup>] Speed after braking
- $P_B$  [kW] Brake power generated by application, average with one braking cycle
- $P_{BSzul}$  [kW] Brake power capacity of brake
- $t_B$  [s] Braking time
- $W_B$  [Nm] Braking energy generated by application
- $W_{BSzul}$  [Nm] Braking energy capacity of the disc brake
- $z$  [h<sup>-1</sup>] Number of braking cycles per hour

The transferred power is based on a maximum disc temperature of 300 °C applicable to Brake Disc thicknesses of up to 25 mm.

## Friction Block Wear Control

### Function

All brakes can be supplied on request with an electrical wear indicator which signals the limit of the friction block wear. The control lamp in the wear monitor indicates when the friction blocks need to be replaced. In addition, the output relay can trigger a signal in the central control station.

### Friction Blocks with Signal Cable

Friction blocks with signal cable are used to monitor wear. Cable length 25 cm with plug connection.

### Wear indicator

Housing:	Makrolon
Insulation:	IP 65
Colour:	Grey, RAL 7035
Temperature range:	-50° C to 60° C
Output:	Relay 6A / 230 V AC

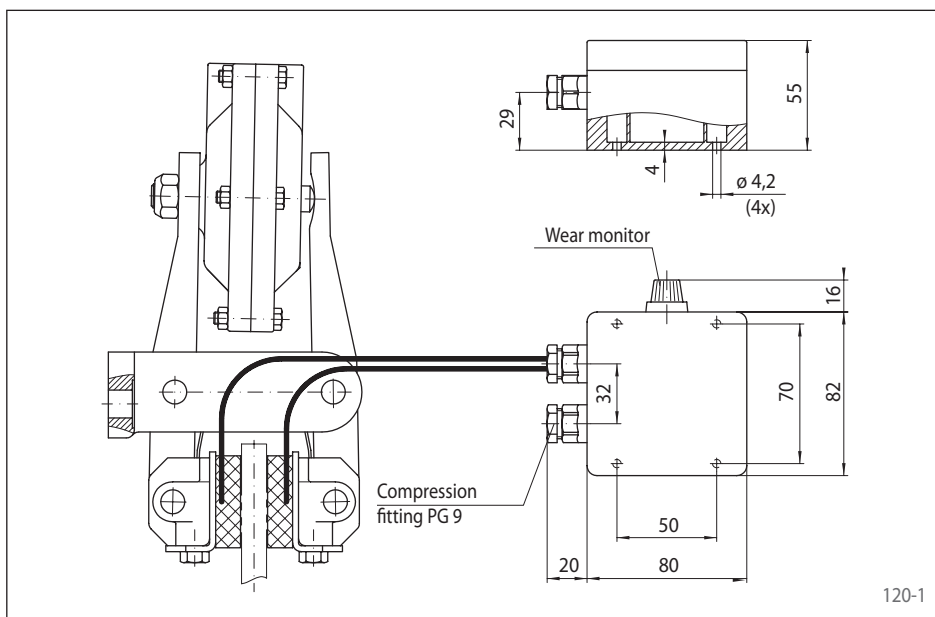

Article Number for supply voltage	
24 V DC	230 V AC, 50 Hz
3511-000001-B024VG	3511-000001-B220VW

## Universal Transformer

The Universal Transformer is used to operate a DH 012 FEM or DV 020 FEM Brake Caliper.

Output: 0,25 kVA

Primary voltages:

200 V, 220 V, 240 V, 260 V, 280 V, 300 V, 310 V, 330 V, 350 V, 360 V, 380 V, 400 V, 420 V, 440 V, 480 V, 500 V, 530 V and 550 V

Secondary voltages:

115 V or 230 V

The Universal Transformer is manufactured in accordance with EN 61558 / VDE 0570:

- Clamps in accordance with VDGB-4
- Insulation class T40/E
- Safety class 1

Article Number: 3503-000001-000000

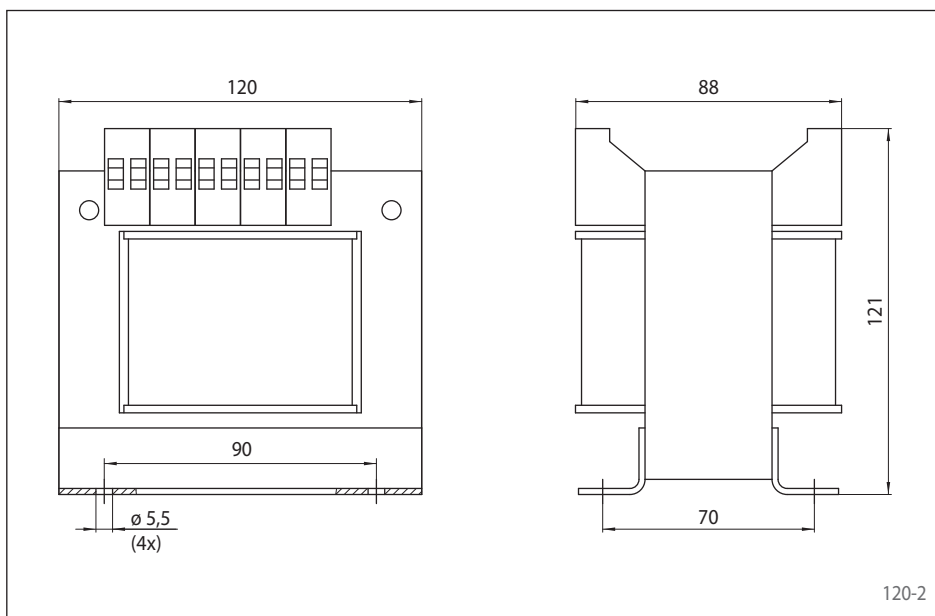

# RCS® Pull Cable and RCS® Hand Brake Lever

## RCS® Pull Cable

RCS® Pull Cable for Brake Calipers DV 020 FKM and DH 020 FKM as well as DV 020 MKM and DH 020 MKM are available in variable cable lengths.

Cable ends are designed for attachment to Brake Calipers or RCS® Hand Brake Lever B 50452.

### Features

- Slide ease
- Stainless steel inner member wrap
- Suitable for small bending radii
- Galvanized steel elements
- Stainless steel drawbar

An extensive product range of RCS® Remote Control Systems can be found in the "RCS® Remote Control Systems" catalogue.

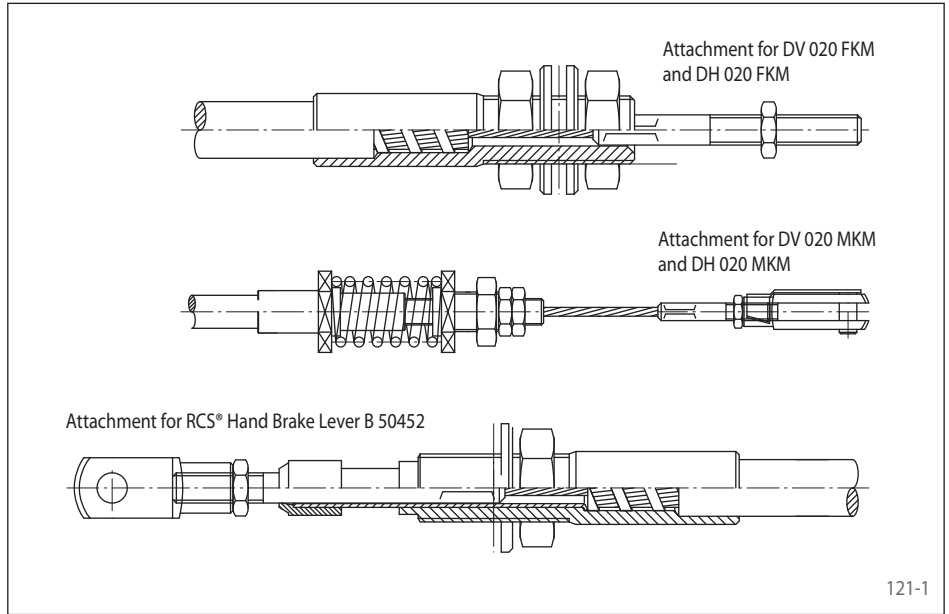

## RCS® Hand Brake Lever B 50452

The RCS® Hand Brake Lever B 50452 is used to operate Brake Calipers DV 020 FKM and DH 020 FKM as well as DV 020 MKM and DH 020 MKM in connection with a RCS® Cable.

Article Number: 4561-000001-R50452

### Features

- Two positions: "open" or "closed"
- Over center locking
- Friction Block Wear compensation
- Attachment for RCS® Pull Cables
- Optional with electric switch (Closer or Opener) available

An extensive product range of RCS® Remote Control Systems can be found in the "RCS® Remote Control Systems" catalogue.

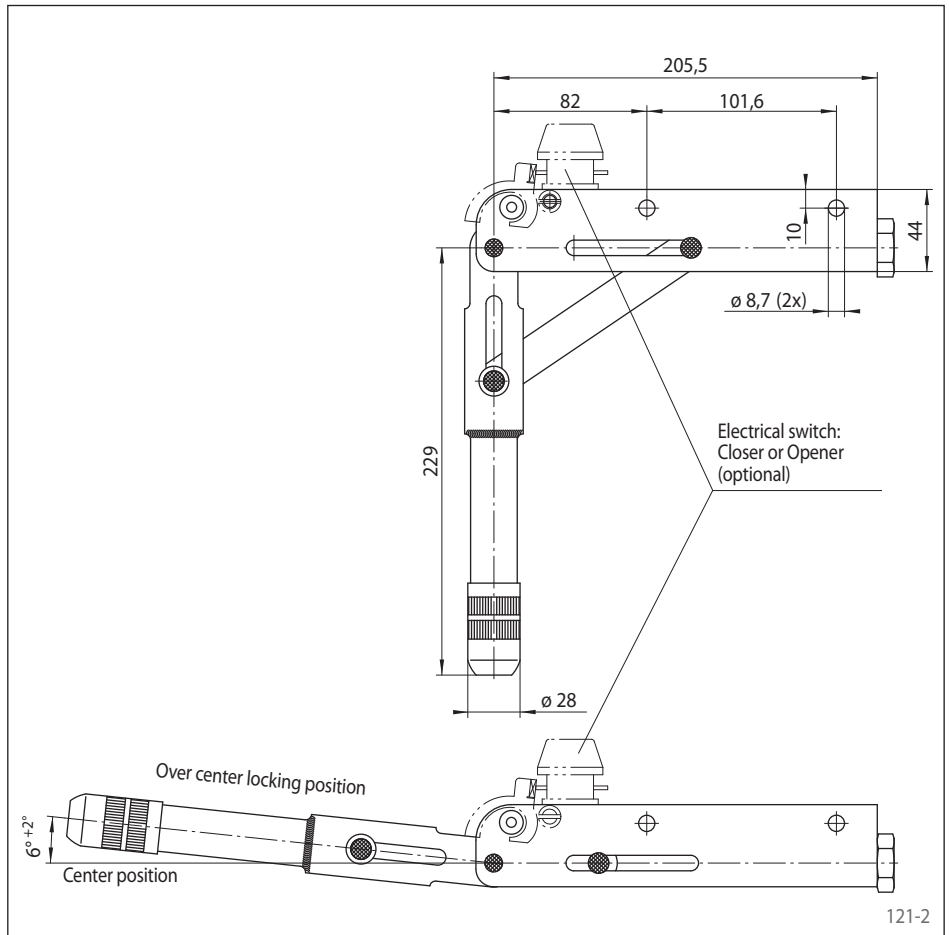

## Control System BCS 600

### For controlled braking ...

- with pre-set braking distance
- with pre-set deceleration
- with pre-set braking time

We command  
braking actions



## Belt conveyors in mining industry



### Industrial Application

Brakes are used to stop declining conveyor belts in the mining industry. The brakes should prevent the belt from overshooting or rotating in the reverse direction. The load is not known at the time of braking and consequently the necessary braking torque is unknown.

### Brake system requirements

The required braking force transferred onto the belt depends on

- the pre-set braking distance,
- the current load condition,
- the current environmental conditions
- and fluctuations in friction coefficient between pad and disc caused by temperature variations during braking.

### For controlled braking ...

- with pre-set braking distance



## Elevator car drive for underground mining

### Industrial Application

The deceleration of elevator cars has to comply with certain regulations. Oscillations in longitudinal direction should be avoided. The load at the time of braking is unknown and could lead to peak loads in the ropes as well as rope slipping on the drum.

### Brake system requirements

The required braking force transferred onto the ropes depends on:

- the permissible deceleration,
- load variations,
- the current environmental conditions
- and fluctuations by temperature variations during braking.



Source: Josef Wiegand GmbH & Co. KG

### For controlled braking ...

- with pre-set deceleration

## Escalators and moving walkways



### Industrial Application

On escalators and moving walkways injuries can occur by stopping too quickly. Regulations prescribe a braking time of 2 - 3 seconds. The number of passengers on the escalator is not known at the time of braking and consequently the necessary braking torque is unknown.

### Brake system requirements

The required braking force transferred onto the escalator depends on:

- the pre-set braking time,
- the admissible deceleration for passenger transport,
- load variations,
- the current environmental conditions
- and fluctuations by temperature variations during braking.

### For controlled braking ...

- with pre-set braking time

## Short description

The Control System BCS 600 is a brake control system for hydraulically released or hydraulically activated brakes, based on adjustable hydraulic pressure.

Herewith, demanding braking actions (preset braking time, deceleration and braking distance) are performed reliably. At the same time the BCS 600 accomplishes important safety and monitoring functions. It consists of a control unit and a hydraulic power pack used in conjunction with brakes from the RINGSPANN product range.



## Control braking actions

The standstill of the system will be reached independent of general conditions with, consistent braking either by

a pre-set braking distance

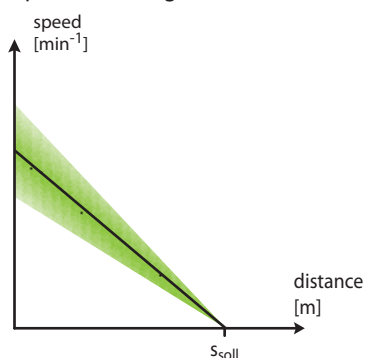

a pre-set deceleration

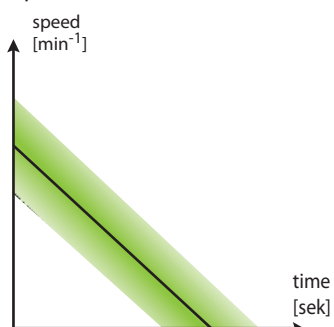

a pre-set braking time

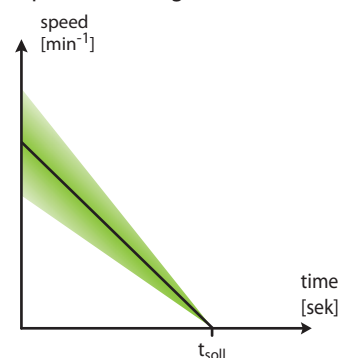

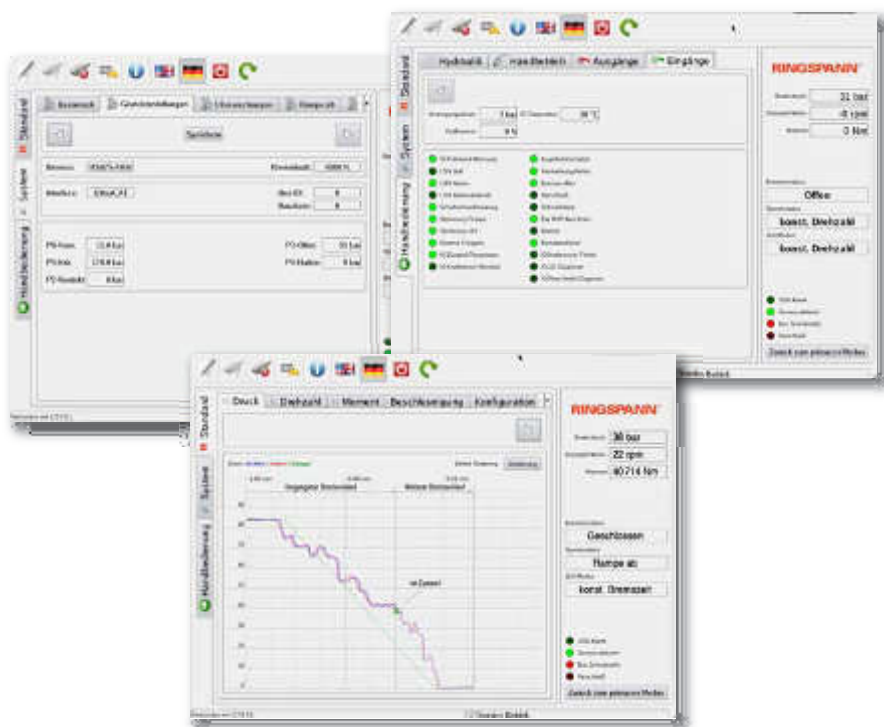

Touchpanel as graphical user interface

## Features

- Fast reduction of the gap between disc and brake pad
- Continuous monitoring of rotational speed, hydraulic pressure, oil temperature and rotational direction
- Operation as a stand alone braking system is possible
- Periodically light braking to clean the brake disc
- Graphical visualization of the braking process in real time
- Redundant installation of a second braking system is possible (one supports the other if necessary)
- Retrofit or upgrade of outdated braking systems is possible
- Permanent logging of operating data and system events
- Spring pressure monitoring



Controller IPC

## Technical specifications

- Large tank volume
- System pressure: up to 200 bar
- Supply voltage: 110 VAC-50/60 Hz, 230 VAC-50/60 Hz, 400 VAC-50/60 Hz
- Various sensors
- Ambient temperature (standard): -20° C ... +40° C
- Fieldbus interface:

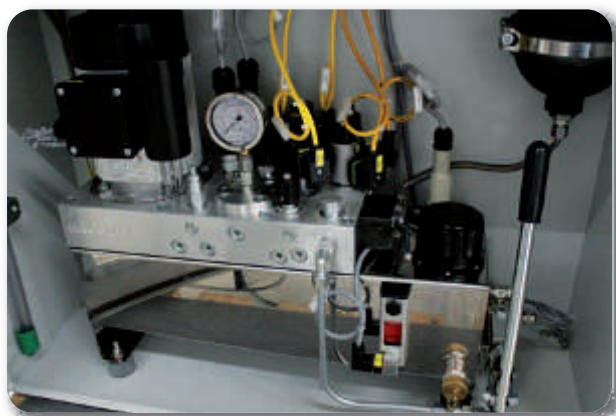

Hydraulic powerpack

## Options

- Hydraulic Accumulator
- Uninterruptible power supply (UPS)
- Remote maintenance via internet or UMTS
- Touch-Panel for data input and brake process visualization, directly on the Brake Control System
- "Cold Climate Version" (-40° C)
- Monitoring of brake pad wear





## Hydraulic Power Unit

- Compact design because of the cylindrical dimensions of the tank
- Optimized oil-connection of pressure side provided by two connection arranged at 90°
- Easy mounting because of two mounting possibilities; therefore, no complex mounting frames are required
- Inside and outside of the tank is oil-resistant powder-coated

Hydraulic Power Units can be made according to customers demand. Please fill out the "Questionnaire for selecting Brake Calipers" on page 134.

126-1



## Pneumatic cabinet

Suitable for brakes up to size 035, configuration according to customers demand.

Pneumatic components include:

- Compressor with 5 liter pressure storage for an output range of 0,5 to 6,0 bar
- Filter regulator unit, including condensate separator
- Valve
- Electric power unit 230 V AC

Cabinet size W x H x D - 400 x 500 x 210 mm

Pneumatic Cabinets can be made according to customers demand. Please fill out the "Questionnaire for selecting Brake Calipers" on page 134.

126-2



# Clamping Unit KE ... FHK

spring activated – hydraulically released



Features	Code
Clamping Unit	K
Standard	E
Sizes 32, 37, 42, 47, 57, 70, 90, 105, 140 or 160 are available	032 to 160
Spring activated	F
Hydraulically released	H
No wear adjustment	K
For piston rod diameter from 12 mm to 115 mm	012 to 115

### Example for ordering

Clamping Unit KE 037 FHK with piston rod diameter 16 mm:

KE 037 FHK - 016

## Description

The Clamping Unit KE ... FHK clamps and holds hydraulic cylinder drawbars with a calculated clamping force in both directions of movement.

The clamping force is generated via built-in disc springs. The Clamping Unit is released by hydraulic pressure.

The units are fitted to cylinders and other machine parts with a connecting flange by the customer.

## Operation

During the working stroke of the hydraulic cylinder, pressure is exerted onto the Clamping Unit. Through this pressure the disc springs are compressed via the piston. In this position, the clamping discs are free of axial tension and thus allow the piston rod to move freely.

When the pressure on the Clamping Unit is removed, the force of the springs work fully onto the piston and therefore also on to the disc pack. The clamping discs translate the axial spring pressure into a radial force applied to the slotted clamping sleeve that is equal to at least five times the axial pressure. The clamping

sleeve transmits the radial clamping forces to the piston rod, thereby holding the piston rod firmly in place.

Each time the pressure falls – even when this was not planned – the Clamping Unit will respond immediately.

## Application

The Clamping Unit secures the piston rod with precision against unintentional axial movements.

For example, on machines with cylinders or linear motors a certain position can be driven in one continuous movement. With the Clamping Unit this position can then be held mechanically with accuracy.

The accuracy of the safety Clamping Unit is independent of the size and the direction of the force on the piston rod up to the maximum

holding force indicated. No movement of the piston rod is required for the holding force to become effective; the clamping force is effective immediately and does not depend on outside forces. If it is necessary to brake the movement of the piston rod, the Clamping Unit would, when pressure falls, produce virtually without delay a constant friction force independent of time. The slowing down of the piston rod is therefore even and protects the decelerated components of the installation.

## Features

- For continuous piston rod clamping
- Spring activated, hydraulically released
- Holding forces transmissible in both directions of movement
- No application of force (lifting) to the piston rod required for release

# Clamping Unit KE ... FHK

spring activated – hydraulically released

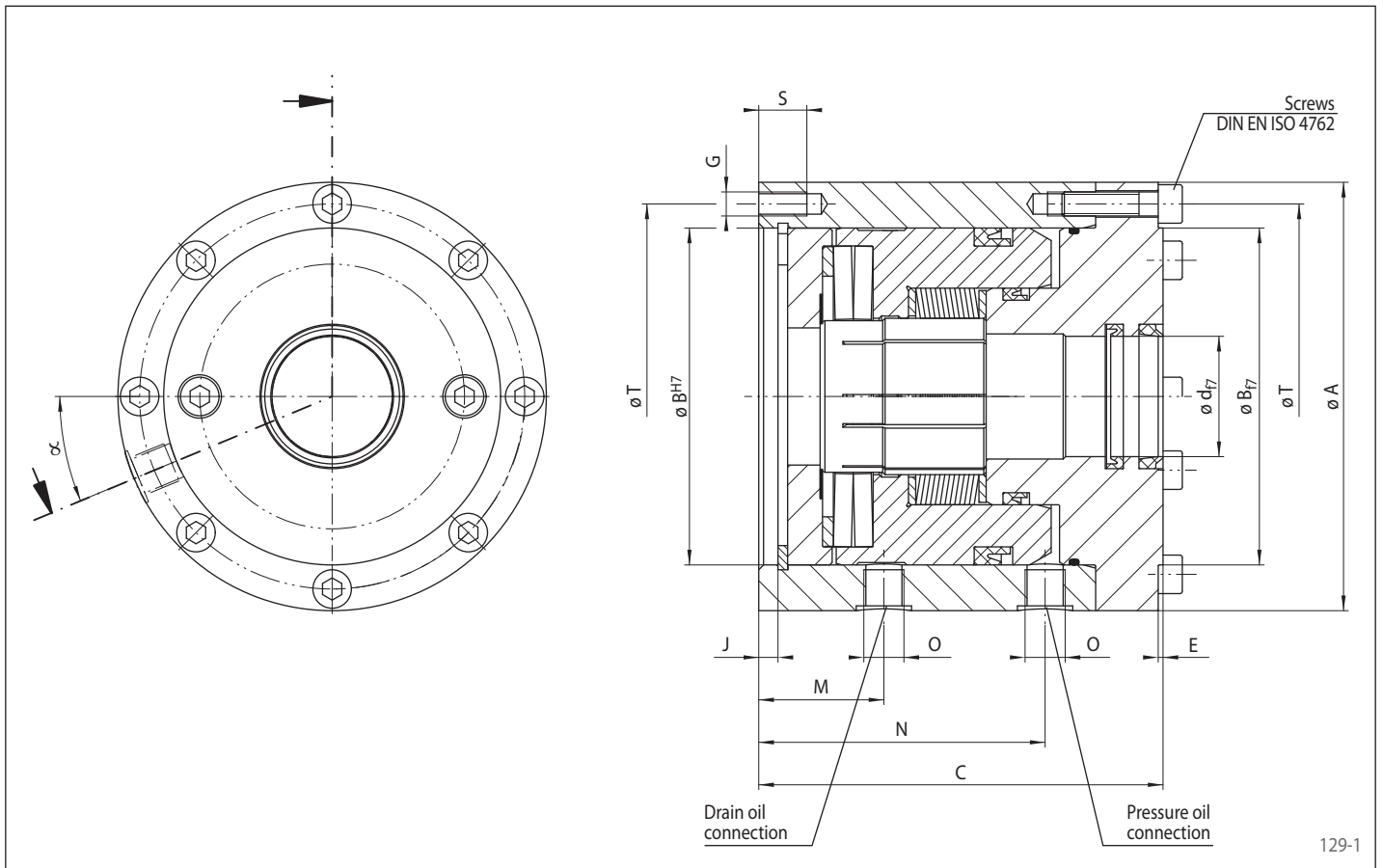

Size	Piston rod- ø d <sup>1)</sup>	Holding force F <sub>H</sub> <sup>2)</sup>	A	B	C	E	G	J	M	N	O	S	T	χ <sup>3)</sup>	Necess. release press.	Max. perm. press.	Oil vol. per stroke	α	Weight
	mm	N	mm	mm	mm	mm		mm	mm	mm		mm	mm		bar	bar	cm <sup>3</sup>	Degree	kg
32	<b>12</b>	2500	72	48	76	2	M 5	5	26	54	R1/8"	9	60	4	57	120	1	22,5	2,1
37	<b>14</b>	5000	85	60	88	2	M 6	6	31	64	R1/8"	11	72	4	68	120	2	22,5	3,4
	16																		
42	<b>20</b>	8000	100	68	100	2	M 6	6	34	72	R1/8"	11	85	4	82	120	2	22,5	5,3
	22																		
47	<b>25</b>	12500	110	80	115	2	M 6	7	42	85	R1/8"	15	92	6	84	120	3	22,5	7,3
	28																		
57	(30)	19000	130	95	130	2	M 8	7	48	96	R1/4"	16	112	6	88	120	5	22,5	11,5
	<b>32</b>																		
	34																		
70	<b>40</b>	30000	150	116	148	3	M 8	4	52	108	R1/4"	16	132	8	102	120	6	22,5	17,2
	45																		
	<b>50</b>																		
90	(55)	48000	178	140	168	3	M 10	8	52	119	R3/8"	20	160	8	108	160	13	22,5	27,2
	<b>60</b>																		
	<b>63</b>																		
105	70	68000	210	168	185	3	M 12	10	60	133	R3/8"	22	190	8	122	160	17	22,5	41,2
	<b>80</b>																		
140	(85)	120000	273	220	230	3	M 14	12	75	172	R3/8"	25	250	12	115	160	39	15	86,9
	<b>90</b>																		
	<b>100</b>																		
160	110	200000	330	270	270	5	M 18	16	90	200	R3/8"	38	300	12	110	160	64	15	148,2
	(115)																		

<sup>1)</sup> Diameter printed in bold to be preferred. Diameter line without ( ) corresponds to DIN 24334.

<sup>2)</sup> Please note recommendations on page 132.

<sup>3)</sup> Number of tapped holes G or screws DIN EN ISO 4762 on pitch øT.



# Clamping Unit KE ... FPK

spring activated – pneumatically released



Features	Code
Clamping Unit	K
Standard	E
Sizes 40, 50, 63, 80 or 100 are available	040 to 100
Spring activated	F
Pneumatically released	P
No wear adjustment	K

### Example for ordering

Clamping Unit KE 040 FPK:

KE 040 FPK

## Description

The Clamping Unit KE ... FPK clamps and holds pneumatic cylinder piston rods with a calculated clamping force in both directions of movement. The clamping force is applied by

disc springs. Clamping force is released by pneumatic pressure.

The Clamping Units can be bolted directly to any cylinder of the ISO series or attached to other machine components with a connection flange provided by the customer.

## Operation

Pneumatic pressure is applied to the Clamping Unit during the working stroke of the pneumatic cylinder. This pressure is transmitted by the piston via the lever spring to the mount and presses the disc springs together. The lever spring translates the pressure into a clamping force. In this position, the clamping discs are free of axial tension and thus allow the piston rod to move freely.

When the pressure on the Clamping Unit is removed, the force of the springs work fully onto the piston and therefore also on to the disc pack. The clamping discs translate the axial spring pressure into a radial force applied to the slotted clamping sleeve that is equal to at least five times the axial pressure. The clamping sleeve transmits the radial clamping forces to the piston rod, thereby holding the piston rod firmly in place.

Each time the pressure falls - even when this was not planned - the Clamping Unit will respond immediately.

## Application

The Clamping Unit secures the piston rod with precision against unintentional axial movements.

For example, on machines with cylinders or linear motors a certain position can be driven in one continuous movement. With the Clamping Unit this position can then be held mechanically with accuracy.

The accuracy of the safety Clamping Unit is independent of the size and the direction of the force on the piston rod up to the maximum holding force indicated. No movement of the piston rod is required for the holding force to become effective; the clamping force is effective immediately and does not depend on outside forces.

# Clamping Unit KE ... FPK

**RINGSPANN®**

spring activated – pneumatically released

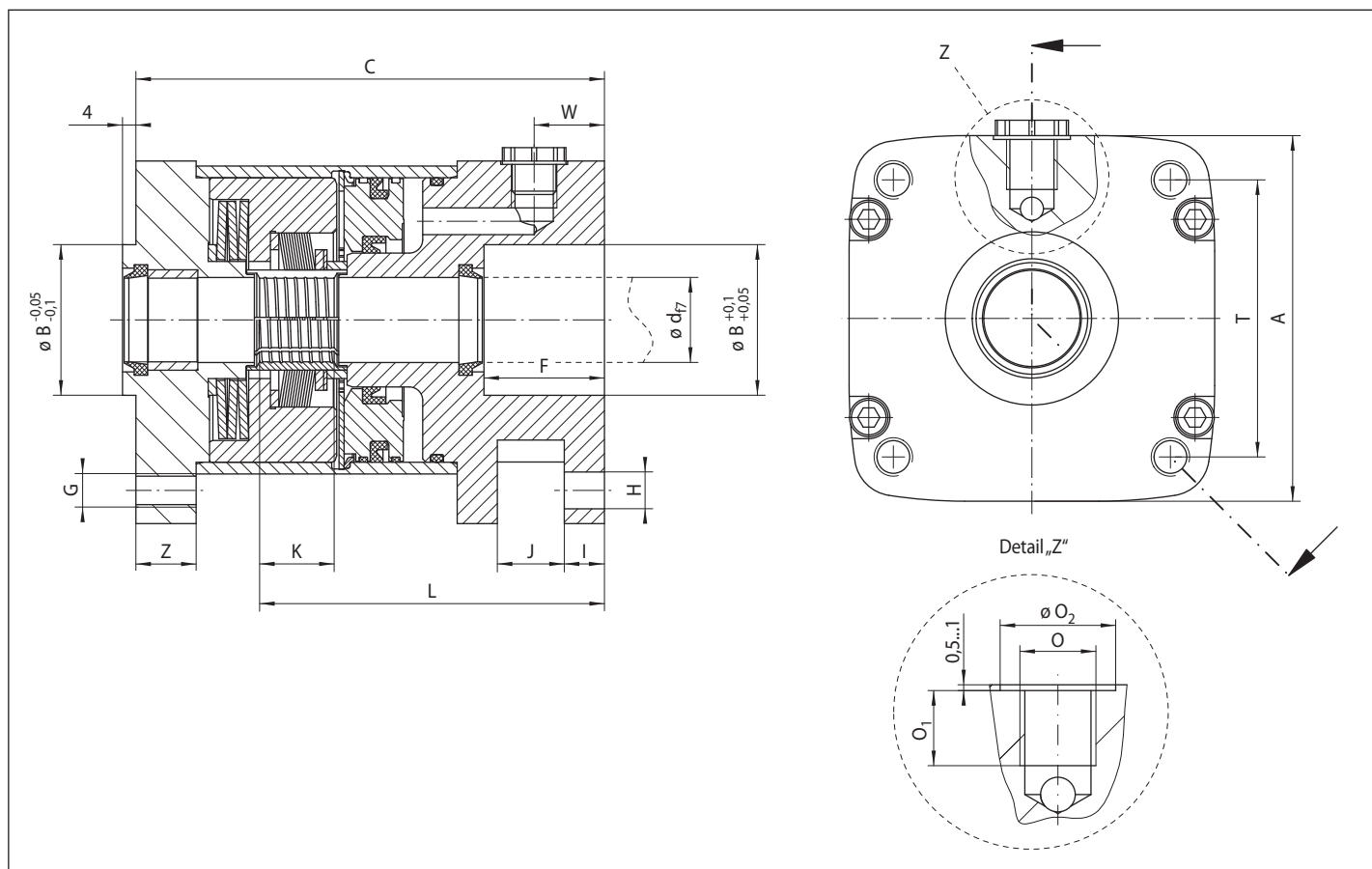

Size	Piston rod- ø d	Holding force $F_H^{1)}$	A	B	C	F	G	H	I	J	O	O <sub>1</sub>	O <sub>2</sub>	T	W	Z	Air vol. per activation	Weight
	mm	N	mm	mm	mm	mm		mm	mm	mm		mm	mm	mm	mm	mm	cm <sup>3</sup>	kg
40	16	1 000	70	35	95	24	M6	6,6	6	14	G1/8	10,5	16	38	15,5	13	5,5	1,1
50	20	1 600	75	40	112	30	M8	9	8	16	G1/4	12,5	20	46,5	22,9	13	13,5	1,5
63	20	2 500	95	45	120	30	M8	9	8	16	G1/4	14	20	56,5	15,0	12	27	3,2
80	25	4 000	95	45	140	36	M10	11	12	20	G1/4	14	20	72	21,0	18	27	3,5
100	25	6 300	120	55	150	40	M10	11	12	20	G1/4	14	20	89	21,0	19	59	5,8

<sup>1)</sup> Please note recommendations on page 132.

## Features

- For continuous piston rod clamping
- Spring activated, pneumatically released
- Connection dimensions compatible with pneumatic cylinders according to ISO
- Direct mounting on pneumatic cylinders
- Holding forces transmissible in both directions of movement
- No application of force (lifting) to the piston rod required for release

## Release pressure

The release pressure of the spring activated pneumatically released Clamping Unit KE ... FPK is min. 5 bar and max. 8 bar.

## Brake Calipers

### Selection of Brake Calipers

When selecting RINGSPANN Brakes, two criteria need to be considered:

- Is the selected combination of brake caliper/ brake disc capable of braking the torque requirement of the application?
- Can the brake disc transfer the frictional heat without damage to adjacent parts?

### Calculation of the braking torque

#### Braking of rotating masses

The necessary braking torque results from the mass inertia moment relative to the brake shaft  $J_{red}$ . When braking to a stop  $n_2=0$ .

$$M_B = M_R = \frac{J_{red}}{t_B} \cdot \frac{n_1 - n_2}{9,55}$$

$$M_R = \frac{J_{red}}{t_B} \cdot \frac{n_1 - n_2}{9,55}$$

$$M_V = \frac{m}{t_B} \cdot \frac{n_1 - n_2}{38,25} \cdot \left(\frac{D_L}{i}\right)^2 \cdot \eta$$

#### Braking of rotating masses with additional motor braking

If an additional braking torque  $M_{Bf}$  is available, e.g. from an electric motor with dynamic braking, then the formula for the necessary braking torque is:

$$M_B = M_R - M_{Bf} = \frac{J_{red}}{t_B} \cdot \frac{n_1 - n_2}{9,55} - M_{Bf}$$

#### Braking of chassis

The required braking torque for a deceleration is made up of the load torque  $M_L$  originating from the net weight  $G$  of the installation, the braking torque for the deceleration of the rotating masses  $M_R$  and the braking torque for decelerating the linear-moving masses  $M_V$  (referred to the braking shaft).

$$M_B = M_L + M_R + M_V$$

$$M_{Lmax} = (G \sin \gamma + F_W - F_F) \cdot \frac{D_L \cdot \eta}{2 \cdot i}$$

After completing this calculation, check whether the braking torque  $M_B$  can be transmitted via the chassis wheel friction.

$$M_B < \mu_R \cdot m \cdot g \cdot \frac{D_L}{2}$$

#### Controlled braking for winding processes

The required braking torque varies between the value  $M_{Bi}$  with minimum winding diameter  $d_i$  and  $M_{Ba}$  with maximum winding diameter  $d_a$ .

$$M_{Bi} = \frac{F_S \cdot d_i}{2}$$

$$M_{Ba} = \frac{F_S \cdot d_a}{2}$$

#### Braking torques and parking torques

The braking torques given in this catalogue are dynamic braking torques. They only apply:

- When the brake linings have been run in,
- original RINGSPANN brake discs, or brake discs made from the recommended material are used and
- friction linings have been selected for the particular application.

If the disc brakes are used as holding brakes then the given brake torques are only applicable as parking torques if the above conditions are met. If running-in is not possible or if the running-in process is omitted, the braking torques given will not be achieved; torque reductions of up to 50% are possible. If static parking torques in accordance with the catalogue torques are required but without running-in, then special friction linings are needed. For such applications, please refer the matter to us for advice.

#### Continuous Slipping

Winding operations may require a variety of processes regarding tension of the wound material and winding speed. We therefore recommend an initial rough calculation of  $M_{Ba}$  and  $M_{Bi}$ .

Please send us the completed questionnaire on page 134 for a more accurate evaluation.

$$P_{Bi} = \frac{M_{Bi} \cdot n_i}{9550} \quad \text{or} \quad P_{Bi} = \frac{F_S \cdot d_i \cdot n_i}{19100}$$

$$P_{Ba} = \frac{M_{Ba} \cdot n_a}{9550} \quad \text{or} \quad P_{Ba} = \frac{F_S \cdot d_a \cdot n_a}{19100}$$

### Formula symbols

$d_i$	[m]	Smallest diameter of roller	$F_F$	[N]	Tractional resistance on the chassis wheel	$J_{red}$	[kg m <sup>2</sup> ]	Reduced inertia moment
$d_a$	[m]	Largest diameter of roller	$F_H$	[N]	Holding force	$i$	-	Gear ratio between chassis wheel and brake shaft
$D$	[mm]	Diameter of brake disc	$F_{Nenn}$	[N]	Nominal holding force	$m$	[kg]	Mass of complete chassis
$D_L$	[m]	Chassis wheel diameter	$F_S$	[N]	Tension on the winding material	$M_B$	[Nm]	Required braking torque
$F$	[N]	Holding force taking account of hydraulic oil and clamping duration	$F_W$	[N]	Wind reaction force on chassis	$M_{Bf}$	[Nm]	Braking torque of the motor
$F_a$	[N]	Maximum axial force including dynamic forces occurring during operation	$G$	[N]	Total weight of chassis	$M_{Ba}$	[Nm]	Braking torque for roller diameter $d_a$

## Clamping Units

### Note for design and installation

#### Holding Force $F_H$

If the system is driven with hydraulic fluid, it is likely that after a certain operating time the piston rod will have a film of oil on it from the installation. Therefore the holding force is affected by the hydraulic oil being used.

The following applies to hydraulic oils H and HL, and to unalloyed oils:

$$F_{Nenn} = F_H$$

For hydraulic oils HLP and HL-XP this applies:

$$F_{Nenn} = F_H \cdot 0,8$$

The nominal holding force thus calculated is reached when the clamping time  $t$  between removal of the release pressure and the application of the load does not fall below a minimum value of 5 seconds. This applies to oils up to VG 100 with a minimum temperature of 20° C at the piston rod.

If the clamping time  $t$  is shorter, then the holding force  $F$  transmissible depending on viscosity should be taken from the diagram.

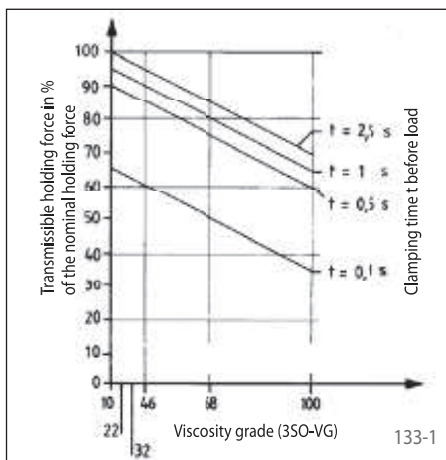

Holding force depending on oil viscosity and clamping period prior to load (temperature at the piston rod 20 °C)

If the hydraulic oil has a large amount of EP additives (eg V 6710, DH 46) the nominal holding force can fall below 80% of the table value. In such a case it would be necessary to carry out field tests. **Solid lubricants like MoS<sub>2</sub>, Graphite or Teflon should never be allowed near the clamping position.**

#### Safety factor

$$S = \frac{F}{F_a}$$

#### Positioning accuracy

Clamping is effected without any axial movement between rod and clamping unit.

Under axial force  $F_H$  an axial shift of up to 0,1 mm may occur in hydraulically released Clamping Units and up to 0,05 mm in pneumatically released Clamping Units between the rod and the clamping unit. This shift is reversed when pressure is released.

#### The rod to be clamped

The rod to be clamped should be made of material with a tensile strength of at least 600 N/mm<sup>2</sup> (e. g. C 45). It must be hard chromium plated or surface hardened and ground. The diameter must be designed with fit f7 in hydraulically released Clamping Units and with fit h8 in pneumatically released Clamping Units and a peak-to-valley height of  $R_t = 5 \mu\text{m}$ . With normal use the maximum pressure at the point of clamping between the piston rod and the clamping unit is 150 N/mm<sup>2</sup>.

#### Sealing and Centering

##### Hydraulically released Clamping Units

are equipped with a rod gasket and stripper on the cover side.

A seal against waste oil should be provided by the customer on the side of the machine or cylinder where the clamping connection is to be located.

##### Pneumatically released Clamping Units

are equipped with strippers on both sides.

In order to ensure a lasting and troublefree operation and to avoid damage to the rod to be clamped, the exact concentricity of the bar towards the machine centering must be kept. (Max. circular runout 0,04 mm.)

#### Release to facilitate Mounting

To insert the rod, hydraulic or pneumatic pressure is applied on the clamping unit.

#### Special Types

If special types with a higher positioning accuracy, higher holding forces or lower release pressures are required, please let us have your enquiries together with the completed questionnaire on the page 135.

$M_{Bi}$	[Nm]	Braking torque for roller diameter $d_i$	$n_1$	[min <sup>-1</sup> ]	Speed before braking	$P_{Bi}$	[kW]	Brake power with winding diameter $d_i$
$M_L$	[Nm]	Load torque	$n_2$	[min <sup>-1</sup> ]	Speed after braking	$t_B$	[s]	Braking time
$M_{Lmax}$	[Nm]	Maximum load torque	$n_i$	[min <sup>-1</sup> ]	Speed at $d_i$	$\gamma$	[°]	Angle of inclination
$M_R$	[Nm]	Deceleration torque of rotating masses	$n_a$	[min <sup>-1</sup> ]	Speed at $d_a$	$\eta$	-	Gear efficiency – if known, calculation with $\eta=0,85$ is advised
$M_V$	[Nm]	Deceleration torque of linear moving masses	$P_B$	[kW]	Brake power generated by application, average with one braking cycle	$\mu_R$	-	Roller friction value on the chassis wheel
			$P_{Ba}$	[kW]	Brake power with winding diameter $d_a$			

Please photocopy or use the PDF-File from our website!

Company: ..... Address: ..... Phone: ..... Fax: .....	Department: ..... Name: ..... Enquiry Ref.: ..... Date: ..... E-mail: .....								
<b>1. Application</b> <input type="checkbox"/> Stopping brake <input type="checkbox"/> Control brake <input type="checkbox"/> Holding brake									
<b>2. Function</b> <table style="width: 100%; border: none;"> <tr> <td style="width: 33%;">                     Activation:  <input type="checkbox"/> spring   <input type="checkbox"/> pneumatically  <input type="checkbox"/> hydraulically  <input type="checkbox"/> manually with threaded spindle  <input type="checkbox"/> manually with Pull Cable                 </td> <td style="width: 33%;">                     Release:  <input type="checkbox"/> pneumatically  <input type="checkbox"/> hydraulically  <input type="checkbox"/> electromagnetically  <input type="checkbox"/> manually with Pull Cable   <input type="checkbox"/> spring  <input type="checkbox"/> non-releasing   <input type="checkbox"/> manually with threaded spindle  <input type="checkbox"/> manually with Pull Cable                 </td> <td style="width: 33%;">                     Existing pressure:                      _____ bar                      _____ bar                       _____ bar                      _____ bar                 </td> </tr> </table>		Activation: <input type="checkbox"/> spring  <input type="checkbox"/> pneumatically <input type="checkbox"/> hydraulically <input type="checkbox"/> manually with threaded spindle <input type="checkbox"/> manually with Pull Cable	Release: <input type="checkbox"/> pneumatically <input type="checkbox"/> hydraulically <input type="checkbox"/> electromagnetically <input type="checkbox"/> manually with Pull Cable  <input type="checkbox"/> spring <input type="checkbox"/> non-releasing  <input type="checkbox"/> manually with threaded spindle <input type="checkbox"/> manually with Pull Cable	Existing pressure: _____ bar _____ bar  _____ bar _____ bar					
Activation: <input type="checkbox"/> spring  <input type="checkbox"/> pneumatically <input type="checkbox"/> hydraulically <input type="checkbox"/> manually with threaded spindle <input type="checkbox"/> manually with Pull Cable	Release: <input type="checkbox"/> pneumatically <input type="checkbox"/> hydraulically <input type="checkbox"/> electromagnetically <input type="checkbox"/> manually with Pull Cable  <input type="checkbox"/> spring <input type="checkbox"/> non-releasing  <input type="checkbox"/> manually with threaded spindle <input type="checkbox"/> manually with Pull Cable	Existing pressure: _____ bar _____ bar  _____ bar _____ bar							
<b>3. Friction block wear</b> Adjustment of brake      Control required? <input type="checkbox"/> Automatic <input type="checkbox"/> Manual <input type="checkbox"/> Yes <input type="checkbox"/> No									
<b>4. The following safety rules must be observed</b> ..... ..... .....									
<b>5. Type of machine</b> ..... .....									
<b>6. Part to be braked</b> ..... .....									
<b>7. Technical Data</b> <table style="width: 100%; border: none;"> <tr> <td style="width: 33%; vertical-align: top;"> <b>Stopping brake:</b>                      Required braking torque _____ Nm                      Required braking time _____ s                      Reduced mass inertia moment to be braked _____ kgm<sup>2</sup>                      Weight of linear masses to be braked _____ kg                      Transmission up to brake shaft    i _____                      Driving speed    v _____ m/s                      Chassis wheel diameter    D<sub>R</sub> _____ mm                      Angle of inclination    γ _____ °                      Speed before braking    n<sub>1</sub> _____ min<sup>-1</sup>                      Speed after braking    n<sub>2</sub> _____ min<sup>-1</sup>                      Idling speed    n _____ min<sup>-1</sup>                      Braking cycles per hour    z _____ h<sup>-1</sup> </td> <td style="width: 33%; vertical-align: top;"> <b>Control brake:</b>                      Tension on winding material    F<sub>S</sub> _____ N                      Speed of material    v _____ m/s                      Max. winding diameter    d<sub>a</sub> _____ m                      Min. winding diameter    d<sub>i</sub> _____ m                      Length of feed reels    L _____ m                      Material to be wound                      _____                      _____                      _____                      Duration of operation    t _____ s                 </td> <td style="width: 33%; vertical-align: top;"> <b>Holding brake:</b>                      Holding brake _____ Nm                      Please note the information given under braking torques and parking torques on page 132.                 </td> </tr> </table>		<b>Stopping brake:</b> Required braking torque _____ Nm Required braking time _____ s Reduced mass inertia moment to be braked _____ kgm <sup>2</sup> Weight of linear masses to be braked _____ kg Transmission up to brake shaft    i _____ Driving speed    v _____ m/s Chassis wheel diameter    D <sub>R</sub> _____ mm Angle of inclination    γ _____ ° Speed before braking    n <sub>1</sub> _____ min <sup>-1</sup> Speed after braking    n <sub>2</sub> _____ min <sup>-1</sup> Idling speed    n _____ min <sup>-1</sup> Braking cycles per hour    z _____ h <sup>-1</sup>	<b>Control brake:</b> Tension on winding material    F <sub>S</sub> _____ N Speed of material    v _____ m/s Max. winding diameter    d <sub>a</sub> _____ m Min. winding diameter    d <sub>i</sub> _____ m Length of feed reels    L _____ m Material to be wound _____ _____ _____ Duration of operation    t _____ s	<b>Holding brake:</b> Holding brake _____ Nm Please note the information given under braking torques and parking torques on page 132.					
<b>Stopping brake:</b> Required braking torque _____ Nm Required braking time _____ s Reduced mass inertia moment to be braked _____ kgm <sup>2</sup> Weight of linear masses to be braked _____ kg Transmission up to brake shaft    i _____ Driving speed    v _____ m/s Chassis wheel diameter    D <sub>R</sub> _____ mm Angle of inclination    γ _____ ° Speed before braking    n <sub>1</sub> _____ min <sup>-1</sup> Speed after braking    n <sub>2</sub> _____ min <sup>-1</sup> Idling speed    n _____ min <sup>-1</sup> Braking cycles per hour    z _____ h <sup>-1</sup>	<b>Control brake:</b> Tension on winding material    F <sub>S</sub> _____ N Speed of material    v _____ m/s Max. winding diameter    d <sub>a</sub> _____ m Min. winding diameter    d <sub>i</sub> _____ m Length of feed reels    L _____ m Material to be wound _____ _____ _____ Duration of operation    t _____ s	<b>Holding brake:</b> Holding brake _____ Nm Please note the information given under braking torques and parking torques on page 132.							
<b>8. Mounting of brake to the machine</b> <input type="checkbox"/> Parallel to brake disc <input type="checkbox"/> Right-angled to brake disc									
<b>9. Brake disc</b> <table style="width: 100%; border: none;"> <tr> <td style="width: 25%;">                     Required disc diameter _____ mm                 </td> <td style="width: 25%;"> <input type="checkbox"/> Form F, without bore or roughbored                 </td> <td style="width: 25%;"> <input type="checkbox"/> Form B, without bore or roughbored                 </td> <td style="width: 25%;"> <input type="checkbox"/> Form S with Shrink Disc RLK 608 for clamping diameter d<sub>S</sub> </td> </tr> <tr> <td>                     Max. permissible disc diameter _____ mm                 </td> <td> <input type="checkbox"/> Form F, with bore d<sub>F</sub><sup>H7</sup> _____ mm                 </td> <td> <input type="checkbox"/> Form B, with bore d<sub>B</sub><sup>H7</sup> with keyway _____ mm                 </td> <td>                     _____ mm                 </td> </tr> </table>		Required disc diameter _____ mm	<input type="checkbox"/> Form F, without bore or roughbored	<input type="checkbox"/> Form B, without bore or roughbored	<input type="checkbox"/> Form S with Shrink Disc RLK 608 for clamping diameter d <sub>S</sub>	Max. permissible disc diameter _____ mm	<input type="checkbox"/> Form F, with bore d <sub>F</sub> <sup>H7</sup> _____ mm	<input type="checkbox"/> Form B, with bore d <sub>B</sub> <sup>H7</sup> with keyway _____ mm	_____ mm
Required disc diameter _____ mm	<input type="checkbox"/> Form F, without bore or roughbored	<input type="checkbox"/> Form B, without bore or roughbored	<input type="checkbox"/> Form S with Shrink Disc RLK 608 for clamping diameter d <sub>S</sub>						
Max. permissible disc diameter _____ mm	<input type="checkbox"/> Form F, with bore d <sub>F</sub> <sup>H7</sup> _____ mm	<input type="checkbox"/> Form B, with bore d <sub>B</sub> <sup>H7</sup> with keyway _____ mm	_____ mm						
<b>10. Installation conditions</b> Ambient temperature from _____ °C to _____ °C      Other information (e. g. special ambient conditions) _____									
<b>11. Estimated requirement</b> _____ pieces (one off application)      _____ pieces/month      _____ pieces/year									





# Product overview

## Freewheels

**RINGSPANN®**  
Power Transmission



### Backstops

Automatic protection against reverse running of conveyor belts, elevators, pumps and fans.



### Overrunning Clutches

Automatic engaging and disengaging of drives.



### Indexing Freewheels

For gradual feed of materials.



### Housing Freewheels

Automatic engaging and disengaging for multimotor drives for installations with continuous operation.



### Cage Freewheels

For installation between customer-supplied inner and outer rings.

## Brakes

**RINGSPANN®**  
Power Transmission



### Industrial Brakes

Spring activated - pneumatically, hydraulically, electromagnetically or manually released.



### Industrial Brakes

Pneumatically activated - spring released.



### Industrial Brakes

Hydraulically activated - non-releasing or spring released.



### Industrial Brakes

Spring activated - hydraulically released.



### Clamping Units

Spring activated - hydraulically or pneumatically released. For secure and precise positioning of piston rods.

## Precision Clamping Fixtures

**RINGSPANN®**  
Clamping Fixtures



### Bonded Disc Packs

Precision Clamping Fixtures based on the unique method of the RINGSPANN Clamping Disc.



### Taper Collets

Precision Clamping Fixtures for clamping thin or thick walled workpieces on long clamping length.



### Taper Sleeves

Precision Clamping Fixtures for clamping compact workpieces with short or long clamping lengths.



### Flat Elements

Very short Precision Clamping Fixtures for clamping thick walled workpieces with large clamping diameter and very short clamping depths.



### Clamping Clutches

For rapid changes and precise clamping of profile rollers or printing rollers in printing presses in gravure and flexographic printing.

## Shaft-Hub-Connections

**RINGSPANN®**  
Power Transmission



### Two-part Shrink Discs

External clamping connection for simple and secure mounting without torque wrench.



### Three-part Shrink Discs

External clamping connection for the fastening of hollow shafts on solid shafts.



### Cone Clamping Elements

Internal clamping connection in small dimensions for high torques.



### Star and Clamping Discs

Shaft-Hub-Connection for frequent clamping and release.



### Star Spring Washers

Axial spring element for pre-loading of ball bearings.

## Overload Clutches & Couplings

**RINGSPANN®**  
Power Transmission



### Torque Limiters with Screw Face

Reliable overload protection for tough operating conditions.



### Torque Limiters with Friction Linings

RIMOSTAT® Torque Limiter for constant slipping torque. Belleville Spring Torque Limiter for simple release.



### Force Limiters

Reliable axial overload protection in rods.



### Tru-Line Flange Couplings

Rigid, easily removable shaft coupling with backlash free cone clamping connections.



### Flexible Couplings

Large allowed radial and angular misalignments. Minimum resiliency.

## RCS® Remote Control Systems

**RINGSPANN®**  
Remote Control Systems



### RCS® push/pull cables

Flexible elements for reliable transmission of axial forces over long distances with short installation radii.



### RCS® pull-only cables

Flexible elements for transmitting pull forces with various standard endparts or according to customer requirements.



### Pedals

Throttle pedals with mechanical cables, pedals for electronic setpoint transmitters from leading manufacturers, brake pedal systems.



### Levers

For different gearboxes: manual, automatic and hydrostatic. Brake levers and controls for general applications.



### Large selection of accessories

Clevises, angle joints, ball joints, mounting brackets, swivel flanges, clamps, clamping brackets, etc.





## Germany

**RINGSPANN GmbH**  
Schaberweg 30-38  
61348 Bad Homburg  
Germany  
+49 61 72 275 0  
info@ringspann.de  
www.ringspann.com

**RINGSPANN RCS GmbH**  
Hans-Mess-Straße 7  
61440 Oberursel  
Germany  
+49 61 72 67 68 50  
info@ringspann-rcs.de  
www.ringspann-rcs.com

Sweden, Finland,  
Denmark, Norway,  
Baltic states

**RINGSPANN Nordic AB**  
Industrigatan 7  
61933 Trosa  
Sweden  
+46 156 190 98  
info@ringspann.se  
www.ringspann.se

## France

**SIAM - RINGSPANN S.A.**  
23 rue Saint-Simon  
69009 Lyon  
France  
+33 4 78 83 59 01  
info@siam-ringspann.fr  
www.ringspann.fr

Netherlands, Belgium,  
Luxembourg

**RINGSPANN Benelux B.V.**  
Nieuwenkampsmaten 6-15  
7472 De Goor  
Netherlands  
+31 547 26 13 55  
info@ringspann.nl  
www.ringspann.nl

## Switzerland

**RINGSPANN AG**  
Sumpfstrasse 7  
6300 Zug  
Switzerland  
+41 41 748 09 00  
info@ringspann.ch  
www.ringspann.ch

## Great Britain, Ireland

**RINGSPANN (U.K.) LTD.**  
3, Napier Road  
Bedford MK41 0QS  
Great Britain  
+44 1234 3425 11  
info@ringspann.co.uk  
www.ringspann.co.uk

Austria, Hungary,  
Slovenia

Edmayr Antriebstechnik GmbH  
Thalham 20  
4880 St. Georgen  
Austria  
+43 7667 68 40  
office@edmayr.at  
www.ringspann.com

## Spain, Portugal

**RINGSPANN IBERICA S.A.**  
C/Uzbina, 24-Nave E1  
01015 Vitoria  
Spain  
+34 945 22 77-50  
info@ringspann.es  
www.ringspann.es

## Italy

**RINGSPANN Italia S.r.l.**  
V.le A. De Gasperi, 31  
20020 Lainate (MI)  
Italy  
+39 02 93 57 12 97  
info@ringspann.it  
www.ringspann.it

## Poland

RADIUS-RADPOL sp.j.  
Wiecheć, Labacki  
ul. Kolejowa 16b  
60 185 Skórzewo  
Poland  
+48 61 814 39 28  
info@radius-radpol.com.pl  
www.radiusradpol.pl

Czech Republic,  
Slovakia

Ing. Petr Schejbal  
Mezivrší 1444/27  
147 00 Praha  
Czech Republic  
+420 222 96 90 22  
Petr.Schejbal@ringspann.cz  
www.ringspann.com

## Asia

## Australia, New Zealand

Kempower Pty. Ltd.  
6 Phoenix Court, Braeside  
3195 Victoria  
Australia  
+61 3 95 87 90 33  
dirk@imtec-kempower.com.au  
www.imtec-kempower.com.au

## China, Taiwan

**RINGSPANN Power Transmission  
(Tianjin) Co., Ltd.**  
No. 21 Gaoyan Rd.  
Bin Hai Science and Technology Park  
Bin Hai Hi-Tech Industrial  
Development Area  
Tianjin, 300458  
P.R. China  
+86 22 59 80 31 60  
info.cn@ringspann.cn  
www.ringspann.cn

## India, Bangladesh, Nepal

**RINGSPANN Power Transmission  
India Pvt. Ltd.**  
GAT No: 679/2/1  
Village Kuruli, Taluka Khed  
Chakan-Alandi Road  
Pune - 410501  
India  
+91 21 35 67 75 00  
info@ringspann-india.com  
www.ringspann-india.com

## Singapore, ASEAN

RINGSPANN Office  
Arthur Low  
1 Scotts Road  
#21-10 Shaw Centre  
Singapore 228208  
+65 96 33 66 92  
Arthur.Low@ringspann.com  
www.ringspann.com

## America

## Brazil

Antares Acoplamentos Ltda.  
Rua Evaristo de Antoni, 1222  
Caxias do Sul, RS  
CEP 95041-000  
Brazil  
+55 54 32 18 68 00  
cristiano@antaresacoplamentos.com.br  
www.antaresacoplamentos.com.br

## Africa and Middle East

## Egypt

Shofree Trading Co.  
218 - emtedad Ramsis (2)  
2775 Nasr City Cairo  
Egypt  
+20 2 20 81 20 57  
info@shofree.com  
www.ringspann.com

## Algeria, Morocco, Tunisia

**SIAM - RINGSPANN S.A.**  
23 rue Saint-Simon  
69009 Lyon  
France  
+33 4 78 83 59 01  
info@siam-ringspann.fr  
www.ringspann.fr

## Iran

Rastan Felez Taha Eng Trading Co (RFT)  
Unit No. 8  
461, North Kargar Avenue  
Tehran postal code 1413683164  
Iran  
+98 21 88 00 94 35  
info@rftrft.com  
www.ringspann.com

USA, Canada, Mexico,  
Chile, Peru

**RINGSPANN Corporation**  
10550 Anderson Place  
Franklin Park, IL 60131  
U.S.A  
+1 847 678 35 81  
info@ringspanncorp.com  
www.ringspanncorp.com

## Israel

G.G. Yarom Rolling and Conveying Ltd.  
6, Hamaktesh Str.  
58810 Holon  
Israel  
+972 3 557 01 15  
noam\_a@gg.co.il  
www.ringspann.com

## South Africa, Sub-Saharan

**RINGSPANN Transmission  
Components (Pty) Ltd.**  
96 Plane Road Spartan  
Kempton Park  
P.O. Box 8111 Edenglen 1613  
South Africa  
+27 11 394 18 30  
info@ringspann.co.za  
www.ringspann.co.za